

Installation, Support, and Maintenance Guide

X1 Series Satellite Router

Router Products

September 14, 2017



Copyright © 2017. VT iDirect, Inc., 13861 Sunrise Valley Drive, Suite 300, Herndon, VA 20171, USA.

All rights reserved. Reproduction in whole or in part without permission is prohibited. Information contained herein is subject to change without notice. The specifications and information regarding the products in this document are subject to change without notice. All statements, information and recommendations in this document are believed to be accurate, but are presented without warranty of any kind, express, or implied. Users must take full responsibility for their application of any products. Trademarks, brand names and products mentioned in this document are the property of their respective owners. All such references are used strictly in an editorial fashion with no intent to convey any affiliation with the name or the product's rightful owner.



VT iDirect® is a global leader in IP-based satellite communications providing technology and solutions that enable our partners worldwide to optimize their networks, differentiate their services and profitably expand their businesses. Our product portfolio, branded under the name iDirect®, sets standards in performance and efficiency to deliver voice, video and data connectivity anywhere in the world. VT iDirect® is the world's largest TDMA enterprise VSAT manufacturer and is the leader in key industries including mobility, military/government and cellular backhaul.

Company Web site: www.idirect.net - Main Phone: 703.648.8000

TAC Contact Information: Phone: 703.648.8151 - Email: tac@idirect.net - Web site: tac.idirect.net



iDirect Government™, created in 2007, is a wholly owned subsidiary of iDirect and was formed to better serve the U.S. government and defense communities.

Company Web site: www.idirectgov.com - Main Phone: 703.648.8118

TAC Contact Information: Phone: 703.648.8111 - Email: tac@idirectgov.com - Web site: tac.idirectgov.com

Document Name: ISM_X1_T0000482_RevE_09142017.pdf

Document Part Number: T0000482

Revision History

The following table shows all revisions for this document. Refer to this information to verify the version of this document. To verify the latest version, access the TAC Web site at <http://tac.idirect.net>.

Revision	Date Released	Reason for Change(s)
A	June 30, 2013	Initial release
B	July 07, 2016	Add option: X1 (indoor) 3; altitude 2000 m
C	March 13, 2017	Updated Power Supply Unit Consumption in Table 2-2.
D	May 12, 2017	Updated Appendix D.
E	September 14, 2017	Added a section on Installing Ferrite on the AC to DC Power Cable in Chapter 5 and Removed the X1 Indoor DC Power Supply option

Revision History

Contents

About	xi
Intended Audience	xi
Manual Contents	xi
Document Conventions	xii
Related Documents	xiii
Related Training Services	xiii
Getting Help	xiii
1 Introduction	1
1.1 X1 Router	1
1.2 X1 Outdoor Router	2
2 Specifications	3
2.1 X1 Router Specifications	3
2.1.1 Mechanical and Environmental Specifications	3
2.1.2 Power Specifications	4
2.1.3 RF Specifications	5
2.2 X1 Outdoor Router Specifications	7
2.2.1 Mechanical and Environmental Specifications	7
2.2.2 Power Specifications	8
2.2.3 RF Specifications	8
3 Physical Interfaces	11
3.1 X1 Indoor Router Interfaces	11
3.1.1 X1 Indoor Router Front Panel Power and Network LED Status Indicators	12
3.1.2 X1 Indoor Router Rear Panel	13

3.2 X1 Outdoor Router Interfaces	15
3.2.1 X1 Outdoor Router Panel and LED.	15
3.2.2 X1 Outdoor Router Power Module Unit Connectors	17
4 X1 Router Installation	19
4.1 X1 Router Installation at a Glance.	20
4.2 Unpacking	21
4.3 Typical Items Ordered	22
4.4 Mounting	22
4.4.1 Guidelines for Desktop or Shelf Mounting	22
4.4.2 Guidelines for Rack Mounting	22
4.5 Installation.	22
4.5.1 AC Power Supply (Option 1, 2) Install	23
4.6 Power On.	23
4.6.1 Checking Conditions before Powering Up the System.	23
4.6.2 Powering Up the System.	23
4.7 Preparing the PC/Laptop for Connection to Router	24
4.8 LED Status Indicators	24
4.9 Configuring	25
5 X1 Outdoor Router Installation	27
5.1 X1 Outdoor Router Installation at a Glance	28
5.2 Unpacking	30
5.3 Typical Items Ordered	30
5.4 Mounting the Router	31
5.4.1 Pre-Installation Guidelines for Mounting Configurations	31
5.4.2 Router Mounting Hardware Included	32
5.4.3 Mounting Router to a Wall or Pole.	33
5.5 Mounting the External Power Module.	35
5.5.1 Power Module Mounting Hardware	35
5.5.2 Mounting the Power Module to a Wall or Pole	35
5.6 Installing Ferrite on the AC to DC Power Cable	37
5.7 Connect Weatherproof Ethernet LAN.	40
5.8 Connect Weatherproof Tx and Rx Coax Cable and Connector	42
5.9 Installation.	43

5.9.1 Install AC Option 1	43
5.9.2 Install DC Option 2 or 3	43
5.10 Connect Main Power Supply to Power Module	44
5.11 Connect Power Module to Router	46
5.12 System Power Up	47
5.12.1 Checking Conditions Before System Power Up	48
5.12.2 Normal Temperature Power Up	48
5.12.3 Cold Temperature Power Up	48
5.13 Preparing the PC/Laptop for Connection to the X1 Outdoor Router	49
5.14 LED Status	49
5.14.1 Front Panel Power Indicator	50
5.14.2 Web Interface LED Status Indicators	50
5.15 Configuring the X1 Outdoor Router	50
6 Maintenance and Troubleshooting	51
6.1 Safety Guidelines to Observe During Servicing	51
6.1.1 Servicing	51
6.1.2 Conditions Requiring Service	52
6.2 Maintaining the X1 Router	52
6.2.1 Temperature Control	52
6.2.2 Dust Removal	52
6.2.3 90 Day Regular Maintenance	53
6.3 Maintaining the X1 Outdoor Router	53
6.3.1 Temperature Control	53
6.3.2 90 Day Regular Maintenance	53
6.4 Troubleshooting	54
6.5 Repacking the X1 Router	54
Appendix A Acronyms and Abbreviations	57
Appendix B Tools Needed	61
B.1 Indoor Coax Installation Tools Needed	61
B.2 Outdoor (ODU) Coax Installation Tools Needed	62

Appendix C Coax Cable Preparation	65
Appendix D Ethernet RJ45 Pinouts	69
Appendix E X1 Reset	71
E.1 Level 0 Reset	71
E.2 Level 1 Reset	71

Figures

Figure 1-1. Front and Rear View of the iDirect X1 Satellite Router (Indoor)	2
Figure 1-2. X1 Outdoor Router (Left), and the Power Module (Right)	2
Figure 3-1. X1 Indoor Router Front Panel Indicators.	12
Figure 3-2. X1 Indoor Router Rear Interface Connectors	14
Figure 3-3. X1 Outdoor Router Panel	16
Figure 3-4. X1 Outdoor Router Power Module with Connectors Labeled	17
Figure 5-1. Packaged Items	31
Figure 5-2. Router Mounting Kit Parts	32
Figure 5-3. Attaching the Mounting Plate	33
Figure 5-4. X1 Outdoor Router Wall Mount	34
Figure 5-5. X1 Outdoor Router Pole Mount	34
Figure 5-6. Mounting the Power Module	36
Figure 5-7. Power Module Wall Mount	36
Figure 5-8. Power Module Pole Mount	37
Figure 5-9. 24 VDC Cable End	38
Figure 5-10. Installing Ferrite.	38
Figure 5-11. Ferrite Distance from the Rear	39
Figure 5-12. Wrapping the 4 IN Silicon Tape	39
Figure 5-13. Ferrite Installation Complete	40
Figure 5-14. Power Gland Assembly.	45
Figure B-1. Installation Tools	62
Figure C-1. Coax Cable Cutting Technique	66
Figure C-2. Cutting Technique for Removing Foil in the Braid.	67
Figure C-3. Folding the Braid	67
Figure C-4. Attaching the Compression fitting F-type Connector.	68
Figure C-5. Compression fitting F-Type Weatherproof Plugs and Tool	68
Figure D-1. RJ-45 Cable Connectors, Plug and Receptacle	69

Tables

Table 2-1. X1 Router Mechanical and Environmental Specifications	3
Table 2-2. X1 Router Power Specifications.....	4
Table 2-3. X1 Router RF Specifications	5
Table 2-4. Transmit Phase Noise Parameters	6
Table 2-5. X1 Outdoor Router Mechanical and Environmental Specifications	7
Table 2-6. X1 Outdoor Router Power Specifications.....	8
Table 2-7. X1 Outdoor Router RF Specifications	9
Table 3-1. X1 Router Front Panel LED Indicators.....	13
Table 3-2. X1 Indoor Router Connectors.....	14
Table 3-3. X1 Outdoor Router Panel and LED Descriptions	16
Table 3-5. X1 Outdoor Router Power Module Connector Descriptions	17
Table 3-4. X1 Outdoor Router Connector-Cable Cross-Reference	17
Table 3-6. Pin Assignments for AC Power Module Gland (4 pin)	18
Table 3-7. Pin Assignments for DC Power Module Gland (4 pin)	18
Table 5-1. RJ 45 LAN Ethernet Cable Installation Steps.....	41
Table 5-2. Coax RX and TX Cable Installation	42
Table 5-3. Power Module Power Cable Installation Instructions.....	45
Table 5-4. X1 Outdoor Router Power Module DC to DC Installation Instructions	46
Table 5-5. X1 Outdoor Router Warm-Up Periods	49
Table 6-1. Troubleshooting Events and Actions to Take	54
Table B-1. Recommended Installation Tools and Equipment for Indoor Coax	61
Table B-2. Tools Included in the order.....	62
Table B-3. Recommended Installation Tools and Equipment for Outdoor Coax.....	63
Table C-1. Coax Trim Dimensions.....	66
Table D-1. Ethernet Port Pinouts	69

About

This manual provides important safety and compliance information, and explains how to install and maintain the X1 Router.

This chapter contains the following sections:

- [Intended Audience on page xi](#)
- [Manual Contents on page xi](#)
- [Document Conventions on page xii](#)
- [Related Documents on page xiii](#)
- [Related Training Services on page xiii](#)
- [Getting Help on page xiii](#)

Intended Audience

This manual is intended for use by the VSAT (Very Small Aperture Terminal) equipment installer, System Engineer, and Network Operator responsible for maintaining the iDirect Network. Only qualified service personnel should install and operate the X1 Router solutions. Familiarity with cabling and wiring practices is beneficial.

Manual Contents

In addition to the information in this chapter, this manual also includes the following:

- [Section 1, Introduction on page 1](#) provides an overview and description of the X1 Router
- [Section 2, Specifications on page 3](#) covers the mechanical, environmental and connector interface requirements
- [Section 3, Physical Interfaces on page 11](#) covers connector and LED descriptions
- [Section 4, X1 Router Installation on page 19](#) describes procedures for installing the X1 Router (Ku/C, Ka)
- [Section 5, X1 Outdoor Router Installation on page 27](#) describes procedures for installing the X1 Outdoor Router

- [Section 6, Maintenance and Troubleshooting on page 51](#) covers important maintenance procedures for the X1 Router

The following appendixes are also provided:

- [Appendix A, Acronyms and Abbreviations on page 57](#) provides full wording for selected acronyms, abbreviations, and mnemonics
- [Appendix B, Tools Needed on page 61](#) describes the tools needed
- [Appendix C, Coax Cable Preparation on page 65](#) describes coax cable preparation
- [Appendix D, Ethernet RJ45 Pinouts on page 69](#) describes the pinouts for the NET connection
- [Appendix E, X1 Reset on page 71](#) describes the reset functions

Document Conventions

This section illustrates and describes the conventions used throughout this document.

Convention	Description	Example
Command	Used when the user is required to enter a command at a command line prompt or in a console.	Enter the command: <code>cd /etc/snmp/</code>
Terminal Output	Used when showing resulting output from a command that was entered at a command line or on a console.	<code>crc report all</code> 8350.3235 : DATA CRC [1] 8350.3502 : DATA CRC [5818] 8350.4382 : DATA CRC [20]
Screen Reference	Used when referring to text that appears on the screen on a Graphical User Interface (GUI). Used when specifying names of commands, menus, folders, tabs, dialogs, list boxes, and options.	1. To add a remote to an inroute group, right-click the Inroute Group and select Add Remote . The Remote dialog box has a number of user-selectable tabs across the top. The Information tab is visible when the dialog box opens.
Hyperlink	Used to show all hyperlinked text within a document or external links such as web page URLs.	For instructions on adding a line card to the network tree, see Adding a Line Card on page 108 .



WARNING: A **Warning** highlights an essential operating or maintenance procedure, practice, condition, or statement which, if not strictly observed, could result in injury, death, or long term health hazards.



CAUTION: A **Caution** highlights an essential operating or maintenance procedure, practice, condition, or statement which, if not strictly observed, could result in damage to, or destruction of, equipment or a condition that adversely affects system operation.



NOTE: A **Note** is a statement or other notification that adds, emphasizes, or clarifies essential information of special importance or interest.

Related Documents

The following documents are available at <http://tac.idirect.net>. Please consult these documents for information about installing and using iDirect's satellite network software and equipment.

- *iDX iBuilder User Guide*
- *iDX iMonitor User Guide*
- *iDX Web iSite User Guide*
- *iDX Satellite Router Installation and Commissioning Guide*
- *Quick Start Guide (QSG)*, included in package with router
- *Technical Reference Guide*
- *Link Budget Analysis*
- *iDX Release Notes*

Related Training Services

iDirect offers scheduled classroom training at various global training centers, as well as eLearning, for the installation, operation, maintenance and management of iDirect satellite networks. For training course descriptions and available training dates visit the iDirect web site *Training and Services* at: <http://www.idirect.net/Training-and-Services.aspx> or call +1 (800) 648-8240 for class registration and information.

Getting Help

iDX Software user's guides, installation procedures and guides, an FAQ page, and other documentation that supports iDirect products, are available on the TAC Web site located at: <http://tac.idirect.net>.

To find answers to questions or information, contact the iDirect Technical Assistance Center (TAC) at (703) 648-8151.

iDirect makes every effort to produce documentation that is technically accurate, easy to use, and helpful to our customers. Feedback is welcomed! Send comments to techpubs@idirect.net.

1 Introduction

The X1 Satellite Router is optimized for use in large networks with small inbound channels such as SCADA, point-of-sale and ATM. The X1 features DVB-S2/ACM, TDMA, basic routing and VLAN functionality at a cost-effective price point.

This chapter contains the following sections:

- [Section 1.1, X1 Router on page 1](#)
- [Section 1.2, X1 Outdoor Router on page 2](#)

1.1 X1 Router

X1 Router is a cost-effective satellite router optimized for large, narrow band networks with small inbound channels and single client sites. There are three (3) options for the X1 Router :

- Option 1: X1 (AC Power Supply): 100-240 VAC Single Phase to 24 VDC, 65 W
- Option 2: X1-Ku/C (AC Power Supply): 100-240 VAC Single Phase to 24 VDC, 90 W

The X1 Router leverages the bandwidth efficiencies of the DVB-S2/ACM standard and incorporates basic routing and VLAN functionality. Developed specifically to support large-scale broadband access networks, the low-cost X1 Router is ideal for demanding broadband applications such as SCADA, point-of-sale and ATM.

The X1 Router is shown in [Figure 1-2](#). The router specifications are described in [Section 2.1, X1 Router Specifications on page 3](#). The front panel LEDs and rear panel connectors are described in [Section 3.1, X1 Indoor Router Interfaces on page 11](#).



Figure 1-1. Front and Rear View of the iDirect X1 Satellite Router (Indoor)

1.2 X1 Outdoor Router

The iDirect X1 Outdoor Satellite Router is a cost-effective remote bundle ideal for large, narrowband networks for SCADA, femtocells or pipeline monitoring. There are three (3) options for the X1 Outdoor Router:

- Option 1: 100 - 240 V AC
- Option 2: 12-36 V DC
- Option 3: 36-76 V DC

The X1 Outdoor Router features DVB-S2/ACM and TDMA, basic routing, VLAN functionality and Quality of Service (QoS), and is embedded in a IP67 weatherproof enclosure enabling an extended temperature range, and passive cooling.

The X1 Outdoor Router is shown in [Figure 1-2](#). The router specifications are described in [Section 2.2, X1 Outdoor Router Specifications on page 7](#). The Router and Power Module front panels and Router LED are described in [Section 3.2, X1 Outdoor Router Interfaces on page 15](#).



Figure 1-2. X1 Outdoor Router (Left), and the Power Module (Right)

2 Specifications

The specifications in this chapter describe the mechanical, environmental and RF specifications for the X1 Series Satellite Router. The installation site must accommodate the mechanical and environmental specifications of the X1 Router.

This chapter contains the following sections:

- [Section 2.1, X1 Router Specifications on page 3](#)
- [Section 2.2, X1 Outdoor Router Specifications on page 7](#)



NOTE: The X1 Router operates safely when it is used in accordance with its marked electrical ratings and product usage instructions.

2.1 X1 Router Specifications

This section describes the mechanical, environmental, power, and RF specifications of the X1 Router. Options are described in [Section 1.1, X1 Router on page 1](#) and [Table 2-2 on page 4](#).

2.1.1 Mechanical and Environmental Specifications

The X1 Router mechanical and environmental specifications are defined in [Table 2-1](#).

Table 2-1. X1 Router Mechanical and Environmental Specifications

Category	Description
Dimensions	W 9 in (22.86 cm) x H 1.8 in (4.6 cm) x D 6.8 in (17.3 cm)
Weight	Option 1-2: 1.8 lbs (0.82 kg)
Heat Dissipation	10 W (34.2 BTU/Hour)
Airflow	Natural Convection Cooling
Ambient Temperature	
Operational:	+32° F to +122° F (0° C to +50° C) at Sea Level
Storage:	-40° F to +176° F (-40° C to +80° C)

Table 2-1. X1 Router Mechanical and Environmental Specifications (continued)

Category	Description
Altitude	Operating: ≤ 6,562 ft (2,000 m) Storage: ≤ 35,000 ft (9144 m)
Humidity	Operating: 10 - 90% non-condensing 5 - 95% non-condensing

2.1.2 Power Specifications

Table 2-2 provides the power specifications for the router and the typical BUC/LNB for the X1 Router .



NOTE: Only use the iDirect approved and provided power supply.

Table 2-2. X1 Router Power Specifications

Category	Description
Power Supply Input Voltage Range and Power (W)	Option 1: X1 (AC Power Supply): 100-240 VAC Single Phase to 24 VDC, 65 W Option 2: X1-Ku/C Band (AC Power Supply): 100-240 VAC Single Phase to 24 VDC, 90 W
Frequency	Option 1 and 2: 50-60 Hz
Power Supply Unit Consumption	Option 1: 1.4 A (MAX) Option 2: 1.2 A (MAX)
Router Input Power	Option 1: +24 VDC, 2.7 A, 65 W (MAX) Option 2: +24 VDC 3.75 A, 90 W (MAX) NOTE: To avoid damaging the equipment or to prevent hardware failures, never connect the 90W PSU to an X1 with 2.7A label.
X1 Router DC Consumption	Option 1: 65 W (MAX) Option 2: 90 W (MAX)
DC Power @ Tx Output Connector	Option 1: +24 VDC @ 1.5 A (MAX) over operating temperature Option 2: +24 VDC @ 2.1 A (MAX) over operating temperature
DC Power @ Rx Input Connector	+24 VDC @ 300 mA (MAX)
Protection	Internal, primary current fuse, inside power supply Over current protection Short circuit protection
Power Factor Correction	Option 1, 2: Complies with EN61000-3-2 and EN61000-3-3
Input Transient Response	0.5 mS for 50% Load Change (TYP)

Table 2-2. X1 Router Power Specifications (continued)

Category	Description
Power Supply Input Power Connector	Option 1, 2: IEC-320-C6
Power Cord	Option 1, 2: 18 AWG (American Wire Gauge)
Efficiency	88% (AVG)

2.1.3 RF Specifications

Table 2-3 defines the X1 Router RF specifications and Table 2-3 defines the TX SSB phase noise parameters.

Table 2-3. X1 Router RF Specifications

Category	Description
LNB Support	Options 1-3: Fsym > 10 Msps DRO LNB Fsym > 1 Msps ±10 ppm PLL LNB Fsym > 1 Msps ±35 ppm Uni-Ku LNB Option 1-3: Internal reference LNBs only
Frequency Range (Option 1, 2, 3) Transmit: Receive:	950-1700 MHz 950-2150 MHz
Frequency Tuning Step Size Transmit: Receive:	0.6 Hz Sub-Hertz with Demodulator
RF Power Transmit: Receive, Minimum: Receive, Maximum: Receive Adjustability:	-30 dBm to 0 dBm, 0.5 dB step -130 + 10Log(Sym rate) dBm (Single carrier) -5 dBm (Wideband Composite, MAX) Under AGC for all valid Rx input power range

Table 2-3. X1 Router RF Specifications (continued)

Category	Description										
Transmit SSB Phase Noise	<table border="1"> <thead> <tr> <th>Frequency Offset</th> <th>L Band Phase Noise Options 1-3 dBc/Hz</th> </tr> </thead> <tbody> <tr> <td>0.1 kHz</td> <td>-60</td> </tr> <tr> <td>1 kHz</td> <td>-70</td> </tr> <tr> <td>10 kHz</td> <td>-80</td> </tr> <tr> <td>100 kHz</td> <td>-90</td> </tr> </tbody> </table>	Frequency Offset	L Band Phase Noise Options 1-3 dBc/Hz	0.1 kHz	-60	1 kHz	-70	10 kHz	-80	100 kHz	-90
Frequency Offset	L Band Phase Noise Options 1-3 dBc/Hz										
0.1 kHz	-60										
1 kHz	-70										
10 kHz	-80										
100 kHz	-90										
Typical Phase Jitter at 14 kHz to 1 MHz:	$\leq 1.8^\circ$ rms										
Transmit Carrier Suppression	≤ -40 dBc with output ≥ -20 dBm										
Discrete Spurs	Out-of-band: Option 1 and 2: < 50 dBc, with output ≥ -20 dBm In-band: Option 1 and 2: ≤ -32 dBc with output ≥ -20 dBm										
Modulator Spectral Shaping	DVB-S2 (ETSI EN302307)										
Transmitter On/Off Ratio	50 dB, with output power ≥ -20 dBm										

Table 2-4. Transmit Phase Noise Parameters

Transmit SSB Phase Noise (dBc/Hz) frequency at:	Band Phase Noise Option 1-3 dBc/Hz
0.01 kHz	-29
0.1 kHz	-59
1 kHz	-69
10 kHz	-79
100 kHz	-89
1 MHz	-100
Typical Phase Jitter at 14 kHz to 1 MHz:	$\leq 1.8^\circ$ rms

2.2 X1 Outdoor Router Specifications

This section describes the mechanical, environmental, power, and RF specifications of the X1 Outdoor Router. Options are described in [Section 1.2, X1 Outdoor Router on page 2](#) and [Table 2-6 on page 8](#).

2.2.1 Mechanical and Environmental Specifications

The X1 Outdoor Router mechanical and environmental specifications are defined in [Table 2-1](#).

Table 2-5. X1 Outdoor Router Mechanical and Environmental Specifications

Category	Description
Dimensions	X1 Router: W 10.25 in (26.04 cm) x H 10 in (25.4 cm) x D 3 in (7.62 cm) Power Module: W 5 in (12.7cm) x H 8.75 in (22 cm) x D 2.25 in (5.7 cm)
Weight	X1 Router: 5 lbs (2.27 kg) Power Module: 2.7 lbs (1.19 kg)
X1 Router Heat Dissipation	10 W (34.2 BTU/Hour)
Power Module Unit Heat Dissipation	5 to 8 W (17 to 27.3 BTU/Hour)
Airflow	Natural Convection Cooling
Ambient Temperature	Operational: -40° F to +140° F (-40° C to +60° C) at Sea Level +32° F to +113° F (0° C to +45° C) at 10,000 Feet Storage: -40° F to +176° F (-40° C to +80° C)
Temperature Gradient	1.8° F (1.0° C) per 1 minute
Relative Humidity	Operational: 100% condensing
Altitude	Operating: ≤ 10,000 ft (3048 m) Storage: ≤ 35,000 ft (9144 m)

2.2.2 Power Specifications

The X1 Outdoor Router power specifications are defined in [Table 2-2](#).



NOTE: Only use the iDirect approved and provided power supply.



NOTE: The power supply provides power to the external Power Module. The Power Module supplies DC power only to the X1 Outdoor Router.

Table 2-6. X1 Outdoor Router Power Specifications

Category	Description
Power Supply Input Voltage Range	Option 1: 100 - 240 VAC Option 2: 12-36 VDC Option 3: 36-76 VDC
Frequency	Option 1 (only): 50-60 Hz
Power Supply Power Consumption	Option 1: 1.2 A (TYP), 65 W Option 2: 9 A (MAX), 65 W Option 3: 3 A (MAX), 65 W
Router Input Power	+24 VDC, 2.7 A (MAX)
DC Power Consumption	36 W (TYP), 65 W (MAX)
DC Power @ Tx Output	+24 VDC @ 1.5 A (MAX), 10 MHz Reference
DC Power @ Rx Input	+24 VDC @ 300 mA (MAX), 22 kHz tone
Protection	Internal, primary current fuse (on-board fuse protection in the outdoor Power Module) Over current protection Short circuit protection
Power Factor Correction	Option 1 (only): Complies with EN61000-3-2 Class B and EN61000-3-3
Input Transient Response	4% (recovery within 1% less than 500 m/sec for 50-75% and 75-50% load step)
Router Input Power Connector	IP67 Connector
Power Cord	Option 1: 18 AWG (American Wire Gauge), country dependent Option 2 and 3: 14-18 AWG
Efficiency	85% (AVG)

2.2.3 RF Specifications

The X1 Outdoor Router RF specifications are defined in [Table 2-3](#).

Table 2-7. X1 Outdoor Router RF Specifications

Category	Description										
LNB Support	<p>Fsym > 10 Msps DRO LNB</p> <p>Fsym > 1 Msps +/-10 ppm PLL LNB</p> <p>Fsym > 1 Msps +/-35 ppm Uni-Ku LNB</p> <p>Internal reference LNBs only</p>										
Frequency Range	<p>Transmit: 950-1700 MHz, Composite Power 0 dBm/-30 dBm</p> <p>Receive: 950-2150 MHz, Composite Power -5 dBm/-65dBm</p>										
Frequency Tuning Step Size	<p>Transmit: 0.6 Hz</p> <p>Receive: Sub-Hertz with Demodulator</p>										
RF Power Range	<p>Transmit: -30 dBm to 0 dBm</p> <p>Receive: Single Carrier Input Power: Minimum: -130 +10Log(Symbol Rate) dBm to -5 dBm Pmax=0dBm (MIN), 30 dB attenuation adjustable in 1 dB steps Composite Wideband Input Power: -5 dBm (MAX)</p>										
RF Power Adjustability	<p>Transmit: 1.0 dB Nominal Step Size</p> <p>Receive: Under AGC for all valid Rx input power range</p>										
Typical Transmit and Receive Phase Noise (dBc/Hz) at:	<table border="1"> <thead> <tr> <th>Frequency</th> <th>Phase Noise</th> </tr> </thead> <tbody> <tr> <td>1 kHz</td> <td>-75</td> </tr> <tr> <td>10 kHz</td> <td>-85</td> </tr> <tr> <td>100 kHz</td> <td>-95</td> </tr> <tr> <td>1 MHz</td> <td>-105</td> </tr> </tbody> </table>	Frequency	Phase Noise	1 kHz	-75	10 kHz	-85	100 kHz	-95	1 MHz	-105
Frequency	Phase Noise										
1 kHz	-75										
10 kHz	-85										
100 kHz	-95										
1 MHz	-105										
Typical Phase Jitter at 14 kHz to 1 MHz:	≤ 1.8° rms										
Transmit Carrier Suppression	≤ -40 dBc (MAX)										
Discrete Spurs, harmonics and non-harmonics	≥ 50 dBc, with output ≥ -15 dBm, Inband 32 dBc										
Modulator Spectral Shaping	DVB-S2 (ETSI EN302307)										
Transmitter On/Off	≥ 50 dBc, with output power ≥ -15 dBm										

3 Physical Interfaces

This chapter describes physical interfaces and LEDs on the X1 Indoor Router and the physical interfaces and LED on the X1 Outdoor Router.

This chapter contains the following sections:

- [Section 3.1, X1 Indoor Router Interfaces on page 11](#)
- [Section 3.2, X1 Outdoor Router Interfaces on page 15](#)

3.1 X1 Indoor Router Interfaces

The X1 Indoor Router front panel indicators are described in [Section 3.1.1](#) and the rear panel is described in [Section 3-2](#).

3.1.1 X1 Indoor Router Front Panel Power and Network LED Status Indicators

Once the X1 Indoor Router is powered up with the appropriate Options file, check the LEDs to confirm the router is functioning properly. The front panel indicators are shown in [Figure 3-1](#) and described in [Table 3-1](#).



X1 Indoor Router (65 W)



X1 Indoor Router (90 W)

Figure 3-1. X1 Indoor Router Front Panel Indicators



NOTE: The LED displayed colors (red, yellow, green) indicate the state of the X1 Router and are documented in the *iDX Web iSite User Guide*, *iDX Satellite Router Installation and Commissioning Guide*, and *iDX Release Notes*. The definitions of the states may be software version dependent.

Table 3-1. X1 Router Front Panel LED Indicators

LED Label	LED Color	Indicated X1 Status
RX	Off	Receiver is disabled or not configured.
	Solid Yellow	Downstream carrier is configured, but the demodulator is not locked.
	Slow Flashing Yellow	Downstream carrier is configured and the demodulator is locked. NCR is not locked.
	Solid Green	Downstream carrier is configured, demodulator and NCR are locked.
	Flashing Red	All LEDs simultaneously flashing red indicates a software exception or bad options file.
TX	Solid Yellow	Transmitter is disabled.
	Solid Green	Transmitter is enabled.
	Flashing Red	All LEDs simultaneously flashing red indicates a software exception or bad options file.
NET	Flashing Yellow	Demodulator is not locked on the Downstream carrier.
	Solid Yellow	Demodulator is locked on the Downstream carrier.
	2 Second Flashing Green	Demodulator is locked on the Downstream carrier. Network acquisition is in progress.
	1 Second Flashing Green	Demodulator and NCR are locked on the Downstream carrier. Network acquisition is in progress.
	Solid Green	Network is acquired. Link Layer is up.
	Flashing Red	All LEDs simultaneously flashing red indicates a software exception or bad options file.
POWER	Off	No or low DC power input to the X1.
	Solid Green	Acceptable DC power level to the X1 is detected.
	Solid Yellow	BUC/LNB power fail.
	Flashing Red	All LEDs simultaneously flashing red indicates a software exception or bad options file.

3.1.2 X1 Indoor Router Rear Panel

This section describes and illustrates the rear panel connectors and LED indicators. They are shown in [Figure 3-2](#) and defined in [Table 3-2 on page 14](#). The LAN/RJ45 pin assignments are listed in [Appendix D, Ethernet RJ45 Pinouts on page 69](#).

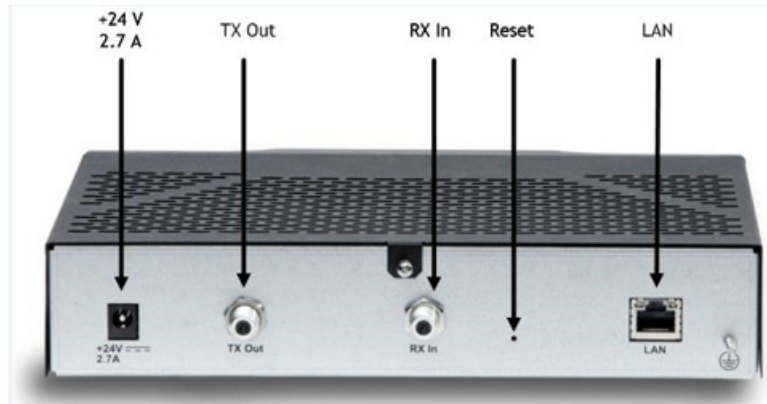

X1 Indoor Router (65W)



X1 Indoor Router (90W)

Figure 3-2. X1 Indoor Router Rear Interface Connectors

Table 3-2. X1 Indoor Router Connectors

Label	Connector Type	Interface and Purpose
Option 1: +24 V \equiv 2.7 A Option 2: +24 V \equiv 3.75 A	CUI 2.5 mm	External +24 VDC 2.7 A (Opt. 1), 3.75 A (Opt. 2) power supply; CUI 2.5 mm NOTE: See Power Specifications Section for Options Definitions
TX Out	75 ohm, F-Type	L-Band Transmit signal to Block UpConverter (BUC) capable of 10 MHz Reference (Options 1,2,3); 75 ohm, F-Type
RX In	75 ohm, F-Type	L-band receive signal and DC power to LNB; 75 ohm, F-Type
Reset, no label	Internally recessed push button	Access to reset push button: Factory default reset

Table 3-2. X1 Indoor Router Connectors

Label	Connector Type	Interface and Purpose
LAN A	RJ-45	Shielded outdoor Ethernet LAN cable (to be bought commercially), 10/100 Base-T Ethernet LAN port connects the X1 Router to the customer LAN Hub/switch; RJ-45
	4-40 mounting stud	Chassis ground; 4-40 mounting stud

3.2 X1 Outdoor Router Interfaces



CAUTION: Install where access to the connectors is unobstructed.

3.2.1 X1 Outdoor Router Panel and LED

The X1 Outdoor Router interface connectors are shown in [Figure 3-3 on page 16](#) and defined in [Table 3-3 on page 16](#). Recommendations and a cross-reference for the connectors and cables are further specified in [Table 3-4 on page 17](#). The reset button is shown in [Figure 3-3 on page 16](#) and is housed above the LAN connector.



NOTE: X1 Outdoor Router has only one LED. However, during installation, the Web Interface (Web iSite) provides four simulated LEDs, reflecting the LEDs, similar to the X1 Indoor Router. The simulated LED displayed colors (red, yellow, green) indicate the state of the X1 Outdoor Router and are documented in the *iDX Web iSite User Guide*, *iDX Satellite Router Installation and Commissioning Guide*, and *iDX Release Notes*. The definitions of the states may be software version dependent. [Table 3-1](#), also, describes the Web iSite simulated LED actions for all X1 Series Routers.

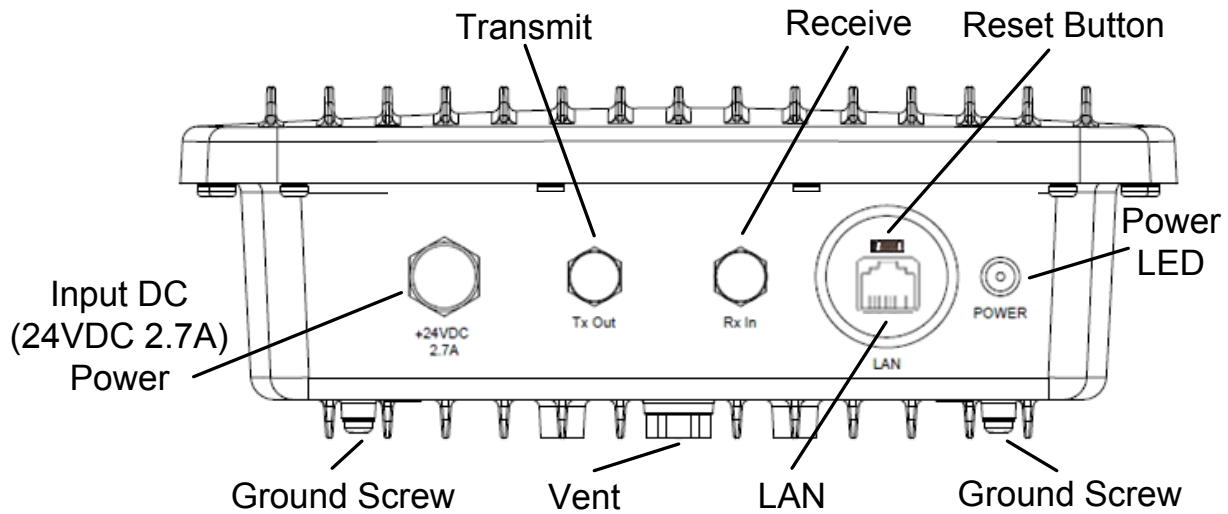

Figure 3-3. X1 Outdoor Router Panel

Table 3-3. X1 Outdoor Router Panel and LED Descriptions

Callout	Label	Connector Type	Interface and Purpose
Input DC (24 VDC 2.7A) Power	+24 VDC 2.7 A	DC connector	Input DC power from the Power Module
Ground Screw		none	Grounding screw (provided)
Vent	none	none	Environmental pressure relief valve
Transmit	TX Out	75 ohm, F-Type	L-Band Transmit signal to Block Up Converter
Receive	RX In	75 ohm, F-Type	L-Band receive signal
Reset Button	None	Above the RJ-45 port, a small square	Factory default reset, location of the reset button shown in Figure 3-3 on page 16 and description of operation in Appendix E, X1 Reset on page 71
LAN	LAN	RJ-45	Ethernet LAN port connecting the X1 Router to the customer LAN Hub switch; See Appendix D, Ethernet RJ45 Pinouts on page 69
Power LED	POWER	Off	No or low DC power input to the X1 Outdoor Router
		Solid Red	Acceptable DC power level to the X1 Outdoor Router is detected

Table 3-4. X1 Outdoor Router Connector-Cable Cross-Reference

Connector Label	Connector Type	Cable Type
24 VDC 2.7A	Supplied with order	DC power cable supplied with order
TX Out and RX In	Either: <ul style="list-style-type: none"> Standard (crimp type) F connector and wrapping with weatherproof tape Waterproof (compression type) F connector 	Coax RG 6 or RG 11
LAN (Ethernet)	RJ-45 Shielded outdoor Ethernet LAN cable, protected with an M25 Cable Gland (gland supplied with order)	Cat 5 - Cat 7

3.2.2 X1 Outdoor Router Power Module Unit Connectors

The Power Module interface connectors for the X1 Outdoor Router are shown in [Figure 3-4](#) and described in [Table 3-5](#). The pin assignments for the AC power connector are defined in [Table 3-6 on page 18](#) and pin assignments for the DC power connector are defined in [Table 3-7 on page 18](#).

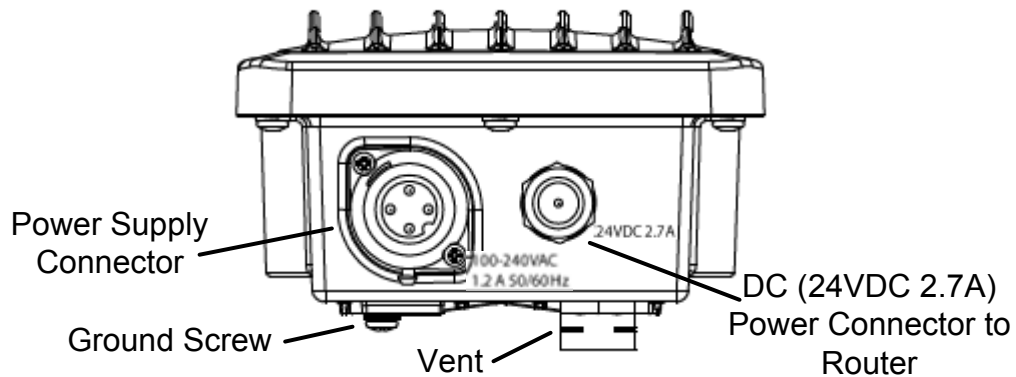

Figure 3-4. X1 Outdoor Router Power Module with Connectors Labeled

Table 3-5. X1 Outdoor Router Power Module Connector Descriptions

Callout	Label	Description
Ground Screw		Grounding screw (provided)
Power Supply Connector	Option 1: 100-240 VAC, 1.2 A 50/60 Hz Option 2: 12-36 V \equiv 9 A Option 3: 36-76 V \equiv 3 A	Power supply connector

Table 3-5. X1 Outdoor Router Power Module Connector Descriptions

Callout	Label	Description
Vent	None	Environment pressure relief vent
DC (24VDC 2.7A) Power Connector to Router	Option 1: 24 VDC 2.7 A Options 2 & 3: 24 V \equiv 2.7 A	DC power connector to Router

Table 3-6. Pin Assignments for AC Power Module Gland (4 pin)



Pin	Definition	Diagram
	Ground (Pin 4)	
1	Option 1: Live (L), 100-240 VAC	
2	Do Not Use	
3	Neutral	

Table 3-7. Pin Assignments for DC Power Module Gland (4 pin)

Pin	Definition	Diagram
	Ground (Pin 4)	
1	Do Not Use	
2	Option 2: +12-36 V DC Option 3: +36-76 V DC	
3	DC Return	

4 X1 Router Installation

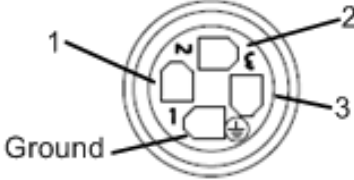
This chapter describes the guidelines and procedures for installing the iDirect Evolution X1 Satellite Router (Indoor) at the VSAT location.

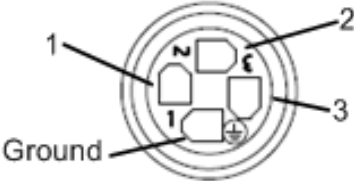
This chapter contains the following sections:

- [Section 4.1, *X1 Router Installation at a Glance* on page 20](#)
- [Section 4.2, *Unpacking* on page 21](#)
- [Section 4.3, *Typical Items Ordered* on page 22](#)
- [Section 4.4, *Mounting* on page 22](#)
- [Section 4.5, *Installation* on page 22](#)
- [Section 4.6, *Power On* on page 23](#)
- [Section 4.7, *Preparing the PC/Laptop for Connection to Router* on page 24](#)
- [Section 4.8, *LED Status Indicators* on page 24](#)
- [Section 4.9, *Configuring* on page 25](#)

4.1 X1 Router Installation at a Glance

Follow these guidelines when installing the X1 Router :



WARNING: This unit is not serviceable. Return unit to provider for all servicing issues.

ATTENTION: Cette unité n'est pas réparable sur site. Renvoyer au fournisseur pour tout réparation.

- Follow all safety guidelines presented in this section
- When selecting the site, consider accessibility, availability of power, signal and network connections, and the possibility of future expansion
- Install the X1 Router in a location where access is unobstructed. Plan for access to both the front and rear panels
- Confirm that the room where the X1 Router operates has adequate ventilation
- Review the ambient temperatures and other environmental specifications listed in [Table 2-1 on page 3](#)
- Ambient air temperature may not cool the X1 Router to acceptable operating temperatures without adequate ventilation
- Select an installation location away from any area that tends to collect dust
- Do not install the X1 Router on the floor
- Use only the iDirect approved and provided Power Module
- Install and ground the X1 Router according to local/national codes and regulations; for ground screw locations see [Figure 3-2 on page 14](#)
- Always remove or disconnect ALL power connections before installing or removing a chassis
- Keep the staging area clear and free of dust during and after installation
- Keep tools, X1 Router components, and shipping boxes away from walkway area
- Do not use attachments unless recommended by the manufacturer as they may cause hazards or damage to equipment
- Do not overload wall outlets, extension cords, or integral convenience receptacles as this can result in a risk of fire or electrical shock



CAUTION: Before working on the outdoor equipment, unplug the power cord from the power source.

The numbered steps in this section must be followed for successful installation of the X1 Router . Steps refer to more detailed sections:

1. Confirm the recommended tools are available for installation. See [Appendix B, Tools Needed on page 61](#).
2. Unpack the router according to the instructions in [Section 4.2, Unpacking on page 21](#).
3. Check that all components are available, see [Section 4.3, Typical Items Ordered on page 22](#).

4. Mount the router as directed in [Section 4.4, Mounting on page 22](#).
5. Prepare the coax cables as directed in [Appendix C, Coax Cable Preparation on page 65](#).
6. Prepare the Ethernet LAN cable and connector. The pinouts are described in [Appendix D, Ethernet RJ45 Pinouts on page 69](#).
7. Connect the power as directed for AC power supplies as described in [Section 4.5, Installation on page 22](#) for either Option 1 or Option2.



CAUTION: Do not connect or disconnect the Tx or Rx IFL cable while the satellite router is powered on; this action may result in damage to the BUC, LNB, and/or X1 Router.

AVERTISSEMENT: Ne pas connecter ou déconnecter les câbles « Tx IFL » ou « Rx IFL » quand le routeur X1 est sous tension, sous risque de dommage au BUC, au LNB, et/ou au routeur X1.

- See [Section 4.5.1, AC Power Supply \(Option 1, 2\) Install on page 23](#)
8. Power the router on as directed in [Section 4.6, Power On on page 23](#).
 9. Prepare the PC/Laptop as directed in [Section 4.7, Preparing the PC/Laptop for Connection to Router on page 24](#)
 10. Monitor the LED indicators with the Web Interface (Web iSite) as directed in [Section 4.8, LED Status Indicators on page 24](#).
 11. Configure the router as indicated in [Section 4.9, Configuring on page 25](#).
 12. If the router needs repacking or maintenance see [Chapter 6, Maintenance and Troubleshooting on page 51](#).

4.2 Unpacking

The X1 Router and related equipment, may be shipped in one or more containers, depending on the type of bundle purchased. Once all of the boxes have been received, perform the following tasks:

- Place the boxes so they are facing upward: refer to the box orientation arrows on the shipping container
- Inspect all shipping containers
- If any damage or other signs of mishandling are evident, inform the carrier and either iDirect or the reseller
- Remove the tape and any exterior covering from the box lid



NOTE: Save the X1 Router shipping boxes after unpacking the system. The boxes may be needed if the unit needs to be moved or shipped in the future.

Remove items from the box only as needed. Confirm the X1 Router components and accessory items listed on the order form have been received, including the optional equipment ordered.

4.3 Typical Items Ordered

Prior to installation, account for all necessary components for a complete VSAT installation. If any items are missing or damaged, contact the Network Operator/Distributor for replacement.

A typical installation includes:

- 1 (one) X1 Router
- One Power Module: +24 VDC Power Module with either Option 1 or Option 2 power module with connectors
- 1 (one) Quick Start Guide (11 X 17 inch brochure)
- Additional components normally required are available in several sizes and types. Consult the iDirect Account Manager for details. The components typically are:
 - One antenna
 - IFL (Inter Facility Link) or coaxial cable appropriate for the installation
 - One appropriate feed assembly for the antenna (OMT)
 - One BUC (Block Up Converter)
 - One LNB (Low Noise Block Converter)

4.4 Mounting



NOTE: The X1 Router is designed for indoor use only.

4.4.1 Guidelines for Desktop or Shelf Mounting

If the X1 Router is mounted in an enclosed shelf, the shelf must have adequate ventilation. An enclosed shelf should have openings on the sides and top to provide air circulation.

4.4.2 Guidelines for Rack Mounting

The X1 Router requires a minimum of two rack units (3.5 inches) of vertical rack space, with proper ventilation. The proposed rack location should be measured before mounting the chassis. An enclosed rack should have louvered sides and top with fans to provide cooling air. Before using a particular rack, check for obstructions, such as a power strip, that could impair rack-mount installation.

4.5 Installation

This section describes installation with an AC power Supply (Option 1,2).

4.5.1 AC Power Supply (Option 1, 2) Install

Perform the steps below with an AC power supply:



NOTE: iDirect recommends that the chassis be powered from a low noise, low transient AC power source.

1. Connect the AC power cord.
2. Turn on power.

4.6 Power On

This section describes powering on the X1 Router .

4.6.1 Checking Conditions before Powering Up the System

Before powering up the system, verify that no RF coax cables are connected to the TX and RX ports on the rear of the chassis.

Also verify that an Ethernet cable connects the LAN port of the PC/laptop to the LAN port of the X1 Router .

CAUTION: Do not connect or disconnect the Tx or Rx IFL cable while the satellite router is powered on; this action may result in damage to the BUC, LNB, and/or X1 Router.



AVERTISSEMENT: Ne pas connecter ou déconnecter les câbles « Tx IFL » ou « Rx IFL » quand le routeur X1 est sous tension, sous risque de dommage au BUC, au LNB, et/ou au routeur X1.

4.6.2 Powering Up the System

The X1 Router can be powered directly from the facility AC power source from 100 VAC to 240 VAC, per specifications in [Chapter 2 on page 3](#).



WARNING: Improper AC power source rating, excessive noise or transients, or undersized circuit breaker will result in service interruption.



WARNING: If power from the chassis must be removed, disconnect power using the AC power cord.

CAUTION: Do not connect or disconnect the Tx or Rx IFL cable while the satellite router is powered on; this action may result in damage to the BUC, LNB, and/or X1 Router.



AVERTISSEMENT: Ne pas connecter ou déconnecter les câbles « Tx IFL » ou « Rx IFL » quand le routeur X1 est sous tension, sous risque de dommage au BUC, au LNB, et/ou au routeur X1.

1. Connect the power module to the X1 Router

2. Apply power

Upon boot up, the **POWER LED** illuminates green, and within several seconds the **STATUS LED** flashes green as the unit performs a self-diagnostic test. If this test is successful, the **STATUS LED** illuminates green. If the test fails, the **STATUS LED** illuminates red.

After the initial hardware diagnostic, the system takes approximately one minute to complete the boot up cycle, during which the **STATUS LED** flashes green. If the application successfully loads, the **STATUS LED** illuminates solid green. If the application cannot start due to configuration or other errors, all LEDs may simultaneously flash red. Once the router is initialized, a typical functional factory default option file is loaded.



NOTE: The **STATUS LED** is normally green. A red **STATUS LED** indicates a malfunction of the X1 Router. iDirect recommends that the chassis be powered from a low noise, low transient power source.

4.7 Preparing the PC/Laptop for Connection to Router

Connect the laptop to the LAN port, see [Section 3.1.2, X1 Indoor Router Rear Panel on page 13](#) location. The LAN port is normally assigned to the WAN (towards the VPN). Its IP address is the next hop for the VPN. The IP address of the X1 Router, 192.168.0.1, is important to have to be able to use the Web Interface program (Web iSite).

Ensure that the PC/laptop:

- Has an IP address that is on the same subnet of the X1 Router
- Includes a Network Interface Card (NIC) connected with a CAT 5 cable to the 10/100 LAN port of the X1 Router
- Has a Web browser installed

4.8 LED Status Indicators

The X1 Router has four LEDs on the front panel, see [Table 3-1 on page 12](#) for a detailed description of the states of the LEDs. For diagnostic purposes, the X1 Router also displays four simulated LEDs in the Web Interface software (see, *iDX Web iSite User Guide*) summarized as follows:



NOTE: The LED displayed colors (red, yellow, green) indicate the state of the X1 Router and are documented in the *iDX Web iSite User Guide*, *iDX Satellite Router Installation and Commissioning Guide*, and *iDX Release Notes*. The definitions of the states may be software version dependent.

- **RX LED** indicates the receive status
- **TX LED** indicates the transmit status
- **NET LED** indicates the network acquisition status
- **POWER LED** indicates whether the unit is powered on or off

4.9 Configuring

When the X1 Router has been installed, next step is installing the firmware and configuring the satellite router. For instructions on how to do this, refer to the *iDX Satellite Router Installation and Commissioning Guide*. To download the guide, go to <http://tac.idirect.net> and click Satellite Routers.

5 X1 Outdoor Router Installation

This chapter describes the guidelines and procedures for installing the X1 Outdoor Router and contains the following sections:

- [Section 5.1, X1 Outdoor Router Installation at a Glance on page 28](#)
- [Section 5.2, Unpacking on page 30](#)
- [Section 5.3, Typical Items Ordered on page 30](#)
- [Section 5.4, Mounting the Router on page 31](#)
- [Section 5.5, Mounting the External Power Module on page 35](#)
- [Section 5.6, Installing Ferrite on the AC to DC Power Cable on page 37](#)
- [Section 5.7, Connect Weatherproof Ethernet LAN on page 40](#)
- [Section 5.8, Connect Weatherproof Tx and Rx Coax Cable and Connector on page 42](#)
- [Section 5.9, Installation on page 43](#)
- [Section 5.10, Connect Main Power Supply to Power Module on page 44](#)
- [Section 5.11, Connect Power Module to Router on page 46](#)
- [Section 5.12, System Power Up on page 47](#)
- [Section 5.13, Preparing the PC/Laptop for Connection to the X1 Outdoor Router on page 49](#)
- [Section 5.14, LED Status on page 49](#)
- [Section 5.15, Configuring the X1 Outdoor Router on page 50](#)

5.1 X1 Outdoor Router Installation at a Glance

Follow these guidelines when installing the X1 Outdoor Router:



WARNING: This unit is not serviceable. Return unit to provider for all servicing issues.

ATTENTION: Cette unité n'est pas réparable sur site. Renvoyer au fournisseur pour tout réparation.

- Follow all safety guidelines presented in this section
- When selecting the site, consider accessibility, availability of power, signal and network cable connections, and the possibility of future expansion
- Review the ambient temperatures and other environmental specifications listed in [Table 2-5 on page 7](#)
- Install the X1 Outdoor Router in a location where access is unobstructed
- Do not install the X1 Outdoor Router on the floor; install only on a wall or pole
- Use only the iDirect approved and provided Power Module
- Install and ground the X1 Outdoor Router and Power Module according to local codes and regulations; for ground screw locations see [Figure 3-3 on page 16](#) and [Figure 3-4 on page 17](#)
- Always remove or disconnect ALL power connections before installing or removing a chassis
- Keep the staging area clear and free of dust during and after installation
- Keep tools, X1 Router components, and shipping boxes away from walkway area
- Do not use attachments unless recommended by the manufacturer as they may cause hazards or damage to equipment
- Do not overload wall outlets, extension cords, or integral convenience receptacles as this can result in a risk of fire or electrical shock



CAUTION: Before working on the outdoor equipment, unplug the power cord from the power source.

The numbered steps in this section must be followed for successful installation of the X1 Outdoor Router. Steps refer to more detailed sections:

1. Confirm the recommended tools are available for installation. See [Appendix B, Tools Needed on page 61](#).
2. Unpack the router according to the instructions in [Section 5.2, Unpacking on page 30](#).
3. Check that all items have been received, see [Section 5.3, Typical Items Ordered on page 30](#).
4. Mount the router as directed in [Section 5.4, Mounting the Router on page 31](#).
5. Mount the external power module as directed in [Section 5.5, Mounting the External Power Module on page 35](#).
6. Prepare the Ethernet cable and connector as described in [Section 5.7, Connect Weatherproof Ethernet LAN on page 40](#).

7. Prepare the coax cables as directed in [Appendix C, Coax Cable Preparation on page 65](#).
8. Prepare the weatherproofing for the coax cables as directed in [Section 5.8, Connect Weatherproof Tx and Rx Coax Cable and Connector on page 42](#).



CAUTION: Do not connect or disconnect the Tx or Rx IFL (coax) cable while the satellite router is powered on; this action may result in damage to the BUC, LNB, and/or X1 Router.

AVERTISSEMENT: Ne pas connecter ou déconnecter les câbles « Tx IFL » ou « Rx IFL » quand le routeur X1 est sous tension, sous risque de dommage au BUC, au LNB, et/ou au routeur X1.



CAUTION: Before working on the outdoor equipment, unplug the power cord from the power source.

9. There are three power supply options (Options 1, 2, 3) and two sections describing installation in [Section 5.9, on page 43](#):
 - See [Section 5.9.1, Install AC Option 1 on page 43](#) for AC power supply input to the Power Module
 - see [Section 5.9.2, Install DC Option 2 or 3 on page 43](#) for either 12-36 VDC or 36-76 VDC power supply input to the Power Module
10. Install the Ferrite on the AC to DC Power Cable.
11. Connect to main power supply: [5.10, Connect Main Power Supply to Power Module on page 44](#).
12. Connect the DC power cable from the Power Module to the router as described in [Section 5.11, Connect Power Module to Router on page 46](#). See [Figure 3-4 on page 17](#) for Power Module connector descriptions.
13. Follow the guidelines for applying power in [Section 5.12, System Power Up on page 47](#).
14. Prepare the PC/Laptop as directed in [Section 5.13, Preparing the PC/Laptop for Connection to the X1 Outdoor Router on page 49](#).
15. Monitor the LED indicators with the Web Interface (Web iSite) as directed in [Section 5.14, LED Status on page 49](#).
16. Configure the router as indicated in [Section 5.15, Configuring the X1 Outdoor Router on page 50](#).
17. If the router needs repacking or maintenance see [Section 6, Maintenance and Troubleshooting on page 51](#).

5.2 Unpacking

The X1 Outdoor Router and related equipment, may be shipped in one or more containers, depending on the type of bundle purchased. Once all of the boxes have been received, perform the following tasks:

- Place the boxes so they are facing upward: refer to the box orientation arrows on the shipping container
- Inspect all shipping containers
- If any damage or other signs of mishandling are evident, inform the carrier and either iDirect or the reseller
- Remove the tape and any exterior covering from the box lid



NOTE: Save the X1 Outdoor Router shipping boxes after unpacking the system. The boxes may be needed if the unit needs to be moved or shipped in the future.

Remove items from the box only as needed. Confirm the X1 Outdoor Router components and accessory items listed on the order form have been received, including the optional equipment ordered. See [Section 5.3, Typical Items Ordered on page 30](#) for the packing list.

5.3 Typical Items Ordered

Prior to installation, account for all necessary components for a complete VSAT installation. If any items are missing or damaged, contact the Network Operator/Distributor for replacement.

A typical installation includes the following:

- One X1 Outdoor Router
- One Power Module, either Option 1, 2, or 3, with connectors, see [Section 5.9, on page 43](#)
- Two (2) hardware mounting kits (one for the X1 Outdoor Router and one for the power module for wall or pole mounting, see [Figure 5-1 on page 31](#), items labeled A and E:
 - Package item labeled A: (part number GTT:GLBAC-WALLMOU-SCC-M) with M6 screws for the X1 Outdoor Router mounting plates
 - Package item labeled E: (part number GTT:GLBAC-WALLMOU-SCC) with M5 screws for the Power Module mounting plates
- One (1) power module gland, package also includes a small Allen wrench, see [Figure 5-1 on page 31](#), item labeled B
- One (1) shielded outdoor Ethernet LAN cable
- One (1) DC 6 foot power cable, see [Figure 5-1 on page 31](#), item labeled D
- One (1) Ferrite, Core, Filter, Impedance 407 OHMS @ 100 MHz, Clamp, SNAP On, RoHS
- One (1) 24 IN Silicone Fusion Tape, Black 1 IN
- Additional components normally required are:
 - One antenna
 - IFL (Inter Facility Link) or Coaxial cable appropriate for the installation
 - One appropriate feed assembly for the antenna (OMT)
 - One BUC (Block Up Converter)

- One LNB (Low Noise Block Converter)



Figure 5-1. Packaged Items

5.4 Mounting the Router

This section provides instructions for an outdoor installation of the router, to a wall or pole, and contains these sections:

- [Section 5.4.1, Pre-Installation Guidelines for Mounting Configurations on page 31](#), read this section first to be sure the site is prepared and the necessary hardware is available
- [Section 5.4.2, Router Mounting Hardware Included on page 32](#)
- [Section 5.4.3, Mounting Router to a Wall or Pole on page 33](#)

5.4.1 Pre-Installation Guidelines for Mounting Configurations

Follow these guidelines installing the X1 Outdoor Router:

- When selecting the site, consider accessibility, availability of power, signal and network cable connections, and the possibility of future expansion
- Install the X1 Outdoor Router in a location where access is unobstructed
- The X1 Outdoor Router operation area must have adequate ventilation
- Do not install the X1 Outdoor Router on the floor, install only on a wall or pole

5.4.2 Router Mounting Hardware Included



CAUTION: If the X1 Outdoor Router and the Power Module are mounted on the same pole, the router must be installed above the Power Module.



CAUTION: The X1 Outdoor Router and the Power Module must be wall or pole mounted with the cable and power connectors on the bottom of the units, facing downward.



NOTE: The X1 Outdoor Router connectors and cables for power, TX, RX, and Ethernet may be attached before or after mounting on a wall or pole.

The X1 Outdoor Router may be mounted to a wall or a pole by using the GLBAC-WALLMOU-SCC-M mounting kit. For easy identification, the mounting kit parts are shown in [Figure 5-2](#). The kit includes:

- 1 mounting plate
- 2 stainless steel tie back straps
- 4 wood screws
- 4 wood/gyprock plugs (anchors)
- 4 M6x20 screws
- 4 flat washers for M6 screws
- 4 spring (lock) washers for the M6 screws
- 1 spacer

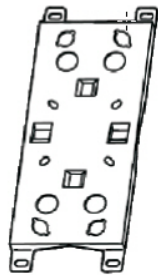

Wall mount x 1



Stainless tie back straps x 2



Wood Screw x 4
&
Wood/Gyprock Plug x 4



M6x20 Screw x4



Washer x 4



Spring Washer x 4



Spacer x 1

Figure 5-2. Router Mounting Kit Parts

5.4.3 Mounting Router to a Wall or Pole

Attach the mounting plate and spacer using the four flat washers, spring washers, and M6x20 screws as shown in [Figure 5-3](#) (horizontal and vertical mounting options are shown). Then follow:

- [Section 5.4.3.1, Router Wall Mount on page 33](#), for wall mounting the router
- [Section 5.4.3.2, Router Pole Mount on page 34](#), for pole mounting the router

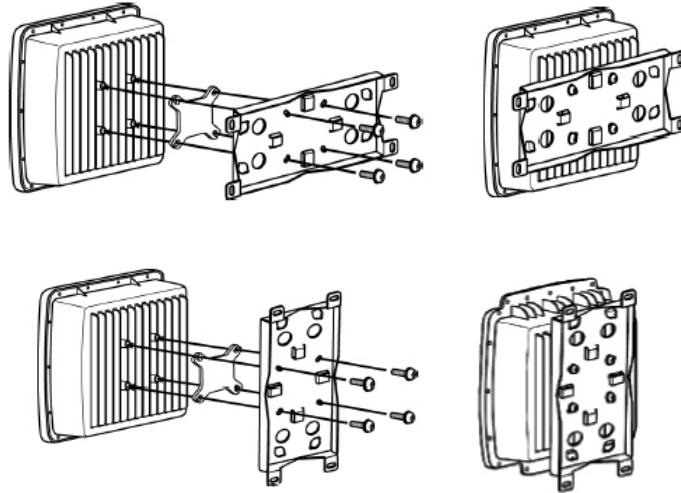

Figure 5-3. Attaching the Mounting Plate

5.4.3.1 Router Wall Mount

The procedure for mounting to a wall is as follows:

1. Connectors and cables for power, TX, RX, and Ethernet may be attached before or after mounting on a wall or pole. See [Section 5.7, on page 40](#) and [Section 5.10, on page 44](#).
2. Attach the mounting plate to the router, as shown in [Figure 5-3](#).
3. Mount the X1 Outdoor Router to the wall, using the four wood screws and wood/gyprock plugs, as shown in [Figure 5-4](#).
4. Follow the instructions in [Section 5.5, Mounting the External Power Module on page 35](#) to mount the power module.

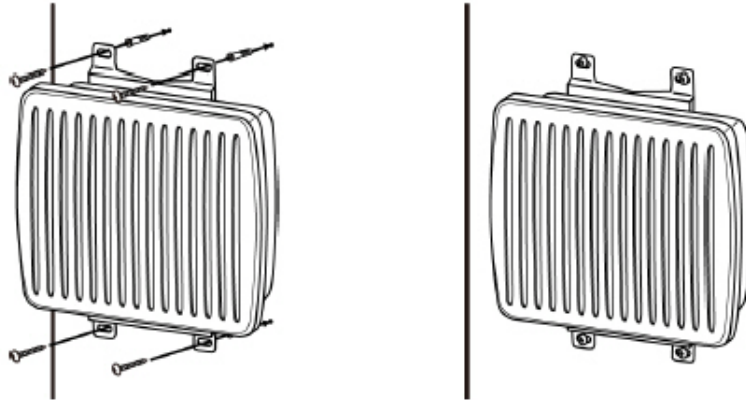

Figure 5-4. X1 Outdoor Router Wall Mount

5.4.3.2 Router Pole Mount

The procedure for mounting to a pole is as follows:

1. Connectors and cables for power, TX, RX, and Ethernet may be attached before or after mounting on a wall or pole. See [Section 5.7, on page 40](#) and [Section 5.10, on page 44](#).
2. Attach the mounting plate to the router, as shown in [Figure 5-3](#).
3. Mount the assembly to the pole using the two stainless steel tie back straps as shown in [Figure 5-5](#) (various mounting options are shown).
4. Follow the instructions in [Section 5.5, Mounting the External Power Module on page 35](#) to mount the power module.

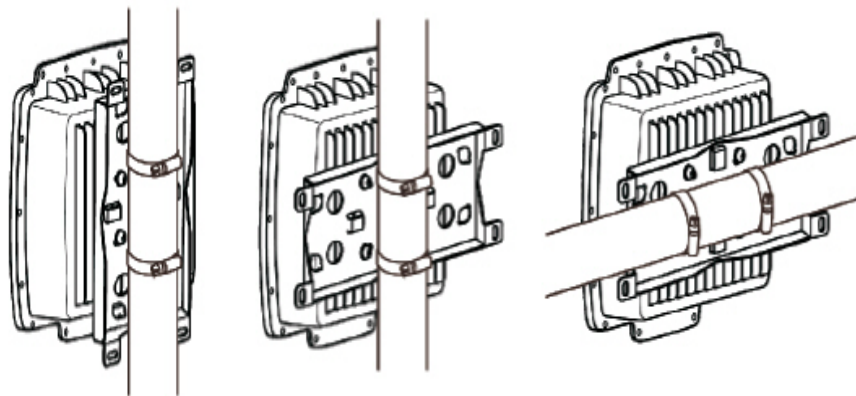

Figure 5-5. X1 Outdoor Router Pole Mount

5.5 Mounting the External Power Module

This section provides instructions for an outdoor installation of the power module, to a wall or pole, and contains these sections:

- [Section 5.5.1, Power Module Mounting Hardware on page 35](#), read this section first to be sure the necessary hardware is available
- [Section 5.5.2, Mounting the Power Module to a Wall or Pole on page 35](#)

5.5.1 Power Module Mounting Hardware

The power module of the X1 Outdoor Router may be mounted to a wall or a pole by using the GTT-MNT-LP22 (GTT:GLBAC-WALLMOU-SCC) mounting kit. The kit includes:

- 1 mounting plate
- 2 stainless steel tie back straps
- 4 wood screws
- 4 wood/gyprock plugs (anchors)
- 4 M5x20 screws
- 4 flat washers for M5 screws
- 4 spring (lock) washers for M5 screws
- 1 spacer



CAUTION: The Power Module must be wall or pole mounted with the cable and power connectors on the bottom of the unit, facing downward.



CAUTION: The Power Module should be installed below or side-by-side the X1 Outdoor Router if installed on poles.

5.5.2 Mounting the Power Module to a Wall or Pole

Attach the mounting plate, to the Power Module, using the M6x20 screws as shown in [Figure 5-6](#). Then follow:

- [Section 5.5.2.1, Wall Mounting the Power Module on page 36](#), for wall mounting the power module
- [Section 5.5.2.2, Pole Mounting the Power Module on page 37](#), for pole mounting the power module

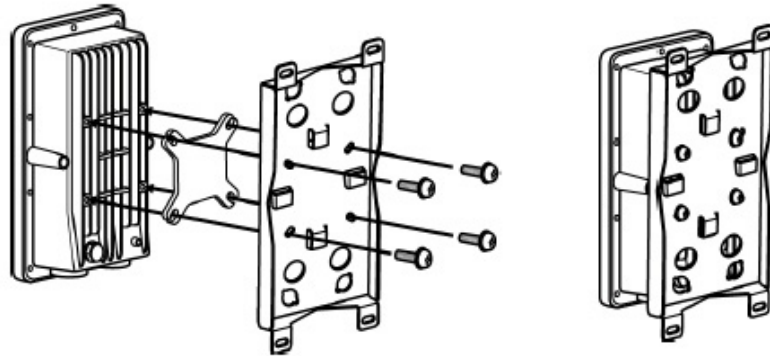

Figure 5-6. Mounting the Power Module

5.5.2.1 Wall Mounting the Power Module

The procedure for mounting to a wall is as follows:

1. Attach the mounting plate to the router, as shown in [Figure 5-6](#).
2. Mount the assembly to the pole using the two stainless steel tie back straps as shown in [Figure 5-7](#).

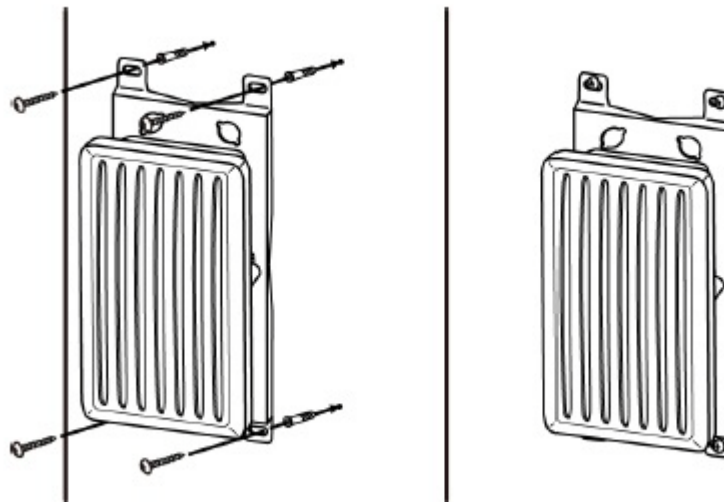

Figure 5-7. Power Module Wall Mount

5.5.2.2 Pole Mounting the Power Module

The procedure for mounting to a pole is as follows:

1. Attach the mounting plate to the power module, as shown in [Figure 5-6 on page 36](#).
2. Mount the Power Module assembly to the pole as shown in [Figure 5-8](#) (horizontal and vertical mounting options are shown).

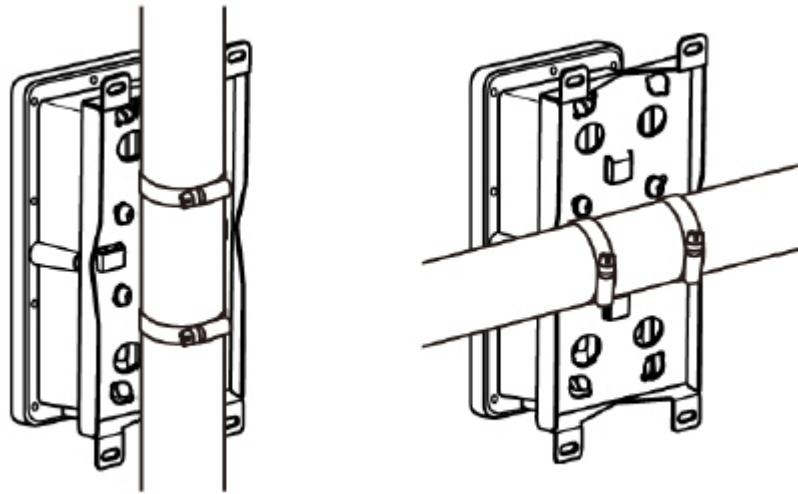
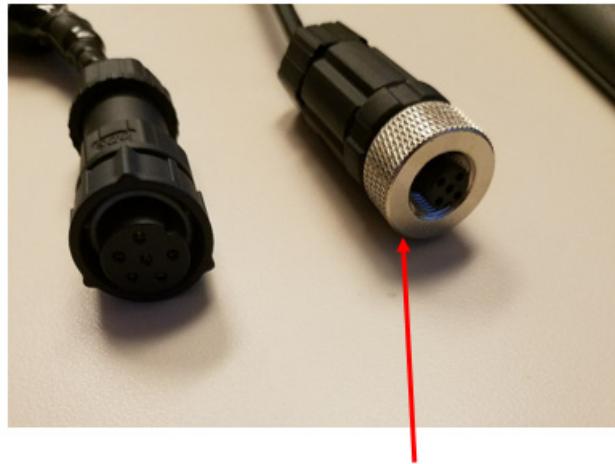

Figure 5-8. Power Module Pole Mount

5.6 Installing Ferrite on the AC to DC Power Cable

1. The following tools are needed before installing the ferrite:
 - Scissor
 - Measurement Device

2. On the AC to DC power cable, identify the end of the 24 VDC cable that connects to the Power Module. See [Figure 5-9](#).



24 VDC End

Figure 5-9. 24 VDC Cable End

3. On the 24 VDC cable, install the Ferrite (included in the kit) as shown in [Figure 5-10](#). Ensure the cable is not damaged when the Ferrite is closed.



Figure 5-10. Installing Ferrite

- The Ferrite should be 3.50 +/- .50 IN rear of the connector as seen in [Figure 5-11](#).



Figure 5-11. Ferrite Distance from the Rear

- Ensure all three snaps on the Ferrite are snapped completely and the Ferrite is closed.
- Cut the silicone fusion tape (included in the kit) into three pieces, ONE 16 IN long and TWO 4 IN long.
 - Wrapping the 16 IN tape—Ensure the Ferrite is secured horizontally for easier application of the tape. Remove the plastic liner from the tape and wrap the tape to cover the ferrite bead completely. Stretch the tape approximately 3/4 its normal width. Overlap each layer of the tape by matching the edge of the tape with the center guideline of the previous layer. Continue the half-lap wrapping procedure until you reach end.
 - Wrapping the two 4 IN tape—Use both the 4 IN pieces to seal both ends of the insulated area from the 16 IN piece of tape. Stretch the tape approximately 2/3 its normal width. The tape must be wrapped onto itself to seal the end of the insulation and to ensure a tight adhesion at the ends of the tape. See [Figure 5-12](#).

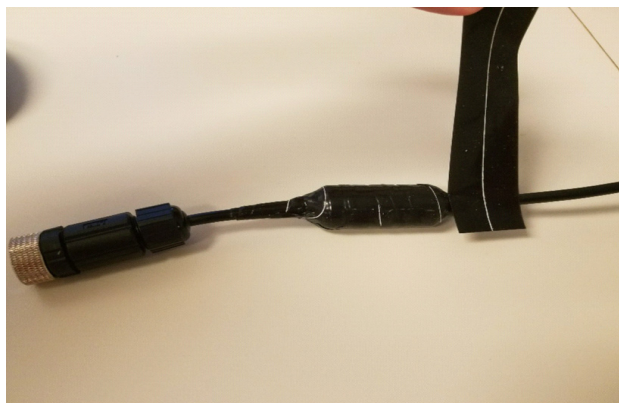

Figure 5-12. Wrapping the 4 IN Silicon Tape

7. Once the Ferrite is installed and secured with the silicon fusion tapes, allow 24 hours at room temperature for the tapes to fully secure and tighten. See [Figure 5-13](#).



Figure 5-13. Ferrite Installation Complete

The AC to DC Power Cable is ready to connect.

5.7 Connect Weatherproof Ethernet LAN

This section describes the preparation and connection of the weatherproof Ethernet LAN cable.



CAUTION: All cables should be installed with a drip loop or service loop.



NOTE: The X1 Outdoor Router connectors and cable for Ethernet may be attached before or after mounting on a wall or pole.

Follow these steps:

1. Prepare the cable and RJ-45 connector: [Appendix D, Ethernet RJ45 Pinouts on page 69](#) lists the pinout details, [Table D-1 on page 69](#) shows the pin order.



CAUTION: Failure to follow the steps in [Table 5-1 on page 41](#), in the order they are listed, can cause damage to the Ethernet LAN cable.

2. Prepare the Ethernet weatherproof assembly as described in [Table 5-1](#).



CAUTION: After tightening the power connectors, wrap with weatherproofing tape, if necessary, following manufacturer's guidelines.

Table 5-1. RJ 45 LAN Ethernet Cable Installation Steps

Step	Instructions	Diagram
1.	<p>Take the gland out of the package and disassemble. Parts are labeled on the right.</p> <p>A - Sealing nut B - “Compression nut” - Clamping claw (black, plastic) and sealing/compression ring (gray, rubber) - part B of the gland is split, so that, if the RJ45 clip is already on the cable, the gasket can be easily opened and placed around the cable.</p> <p>C - Lock nut body</p>	
2.	<ol style="list-style-type: none"> Place C, the lock nut body, onto the cable. Place A, the Sealing nut onto the cable with the threads facing the RJ45 end of the cable, towards the router. The compression nut B, has a slit, so it can be placed on the cable. 	
3.	<ol style="list-style-type: none"> Clip the RJ45 connector and cable into the RJ45 receptacle. Screw the sealing nut (A) into the X1 Outdoor Unit. Push the compression ring (B) into the sealing nut (A). Pass the lock nut body (C) over the compression ring (B). Twist the lock nut body (C) into the sealing nut (A) until tightly compressing the entire gland around the Ethernet cable forming a weather tight seal. It is not necessary to fasten too tightly, just so the compression fits securely. A wrench may be used to secure the assembly to the router. Wrap with weatherproofing (self-amalgamate tape) over the connector and cable junctions according to manufacturer’s guidelines. 	

Table 5-1. RJ 45 LAN Ethernet Cable Installation Steps (continued)

Step	Instructions	Diagram
4.	Completed and connected LAN assembly shown.	

5.8 Connect Weatherproof Tx and Rx Coax Cable and Connector

Table 5-2 describes assembling and connecting the RX and TX weatherproof coax cables.

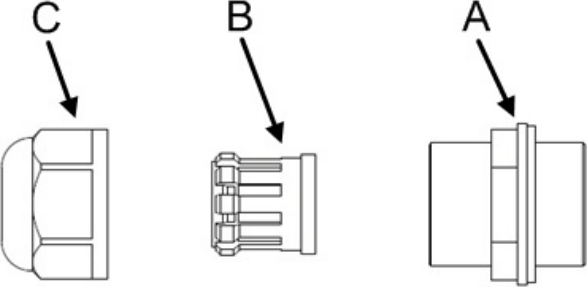
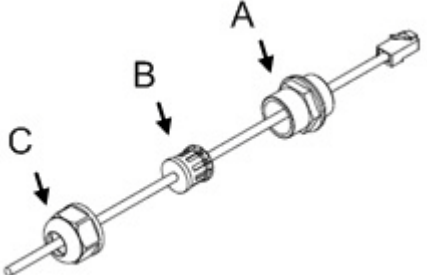
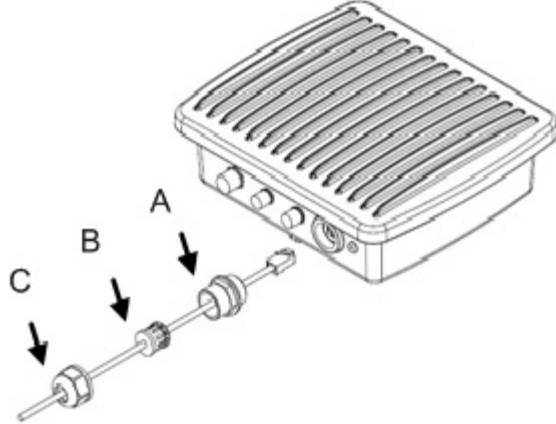
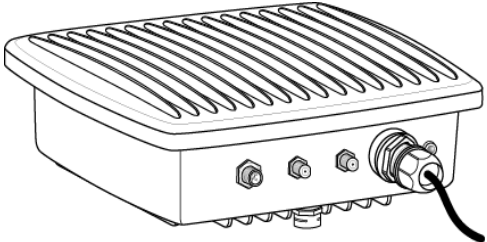

CAUTION: After tightening the power connectors, wrap with weatherproofing (self-amalgamate) tape, if necessary, following manufacturer’s guidelines.



CAUTION: All cables should be installed with a drip loop or service loop.



NOTE: The X1 Outdoor Router connectors and cables for power, TX, RX, and Ethernet may be attached before or after mounting on a wall or pole.

Table 5-2. Coax RX and TX Cable Installation

Step	Instructions	Diagram
1.	Prepare the ends of the coaxial cables (F connectors) for outdoor use.	For preparation diagram details see Appendix C, Coax Cable Preparation on page 65.
2.	Insert F connector assemblies into RX-in interface and lock the connector.	

Table 5-2. Coax RX and TX Cable Installation (continued)

Step	Instructions	Diagram
3.	Use self-amalgamate tape over the connectivity of connector and cable as waterproof function, as per manufacturer's instructions.	
4.	Repeat step 1 and step 2 for TX-out interface.	

5.9 Installation

This section describes installation with either an AC power Supply (Option 1) or a DC Power supply (Option 2 or 3).

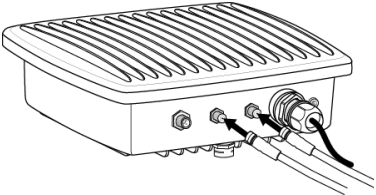
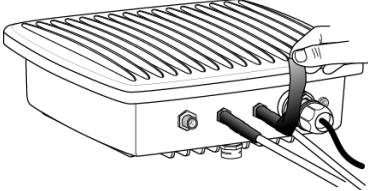
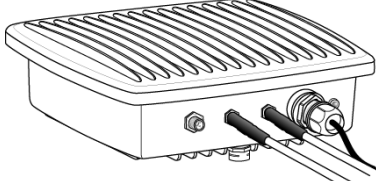
5.9.1 Install AC Option 1

For an X1 Outdoor Router with an AC power supply:

1. Assemble the AC power gland, as described in [Section 5.10, Connect Main Power Supply to Power Module on page 44](#), using the AC Pin assignments in [Table 3-6](#) See [Figure 3-4 on page 17](#) for Power Module connector descriptions.
2. Connect the AC power gland assembly to the Power Supply Connector on the Power Module, labeled **100-240 VAC, 1.2 A 50/60 Hz**.
3. Connect the DC power cable from the Power Module to the router as described in [Section 5.11, Connect Power Module to Router on page 46](#). See [Figure 3-4 on page 17](#) for Power Module connector descriptions.

5.9.2 Install DC Option 2 or 3



CAUTION: If negative voltages are used such as Telecom -48 V DC, the negative most voltage is always connected to -ve terminal (in the Telecom case this would be -48 V) and the positive most voltage is always connected to the +ve terminal (in the Telecom case this would be 0VR). The Chassis can be referenced to +ve, -ve or left floating (i.e. not connected to either +ve or -ve) as required because the power module is fully isolated input to chassis.

For an X1 Outdoor Router using a DC power supply:

1. Assemble the DC power gland assembly, as described in [Section 5.10, Connect Main Power Supply to Power Module on page 44](#), using the DC pin assignments in [Table 3-7](#). See [Figure 3-4 on page 17](#) for Power Module connector descriptions.

2. Connect the DC power gland assembly to the Power Supply Connector on the Power Module, labeled either 12-36 V \equiv 9A, for Option 2; or, 36-76 V \equiv 3A, for Option 3.
3. Connect the DC power cable from the Power Module to the router as described in [Section 5.11, Connect Power Module to Router on page 46](#).

5.10 Connect Main Power Supply to Power Module

This section details connecting the main Power Supply to the Power Module. The main Power Supply may be either AC or DC current. Be sure to follow the instructions for pin assignments of AC or DC power.

[Table 5-3 on page 45](#) shows the detailed installation steps for the Power Module and gland assembly. [Figure 5-14](#) shows a diagram of the gland assembly parts.



CAUTION: Install power on a GFI (Ground Fault Interrupter) protected circuit.



CAUTION: All cables should be installed with a drip loop or service loop.

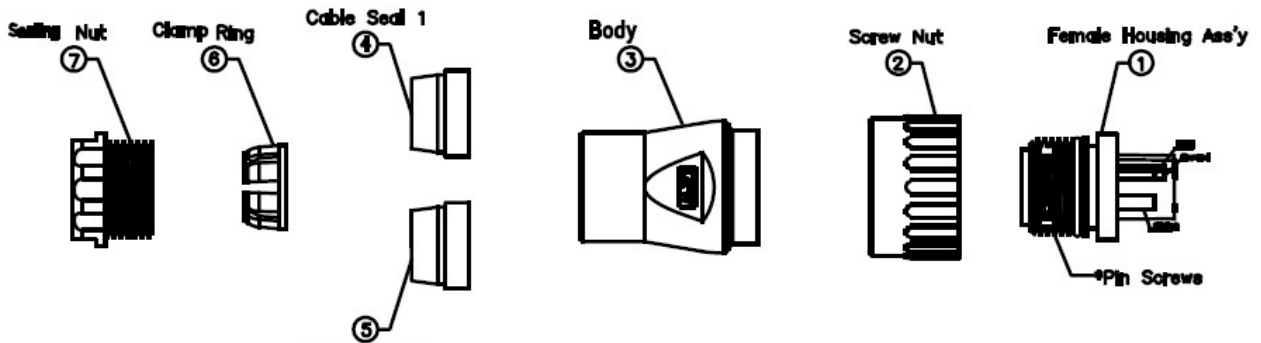
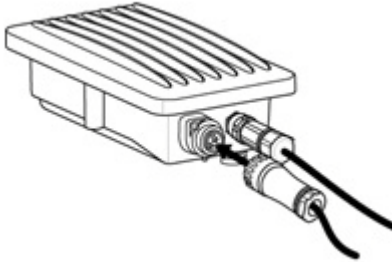

Figure 5-14. Power Gland Assembly

Table 5-3. Power Module Power Cable Installation Instructions

Step	Instructions	Diagram
1.	<p>Make sure all parts of the gland are available</p> <ul style="list-style-type: none"> 1 - Female Housing Assembly (Ass'y) 2 - Screw Nut 3 - Body 4 - 6 mm (.24 in) diameter Cable Seal, which is split for easy application to cable 5 - 12 mm (.47 in) diameter Cable Seal, which is split for easy application to cable 6 - Clamp Ring 7 - Sealing Nut 	
2.	<p>Select a cable seal size (item 4 or 5, in Step 1), providing the best fit for the diameter of cable to be used.</p>	
3.	<p>Table 3-6, Pin Assignments for AC Power Module Gland (4 pin) on page 18 and Table 3-7, Pin Assignments for DC Power Module Gland (4 pin) on page 18 shows the pin assignments for the AC and DC, respectively, power wires in the Female Housing Assembly.</p> <ul style="list-style-type: none"> 1. Connect the AC or DC wires into the assembly according to the pin assignment descriptions in Table 3-6 on page 18 (for AC power) or Table 3-7 on page 18 (for DC power). 2. Using the Allen Wrench (provided), tighten the pin screws for each of the power wires in the Female Housing Assembly. 	

Table 5-3. Power Module Power Cable Installation Instructions (continued)

Step	Instructions	Diagram
4.	<ol style="list-style-type: none"> 1. Connect the power cable into power source. Use a voltmeter to confirm correct AC or DC voltage. Remove plug to de-energize the circuit. 2. Connect the DC power cable into to the Power Module. The connector is keyed and can only be inserted one way. Hand-tighten the screw nut. Weather-tape the assembly as needed following the manufacturer's instructions. 3. Tighten and inspect the cable for final assembly. 	

5.11 Connect Power Module to Router

Follow the steps in [Table 5-4 on page 46](#) to connect the DC power cable from the Power Module to the X1 Outdoor Router. The DC power cable is fully assembled in the kit and ready to connect the Power Module to the X1 Outdoor Router.



CAUTION: After tightening the power connectors, wrap with weatherproofing tape, if necessary, following manufacturer's guidelines.



CAUTION: All cables should be installed with a drip loop or service loop.

Table 5-4. X1 Outdoor Router Power Module DC to DC Installation Instructions

Step	Instructions	Diagram
1.	<p>Observe the location of the keyway in the face of the DC input jack. Align and insert either end of the DC power cable into the jack and tighten the locking ring securely by hand.</p> <p>Tip: connector ends of the DC-DC input cable are identical</p>	

Table 5-4. X1 Outdoor Router Power Module DC to DC Installation Instructions

Step	Instructions	Diagram
2.	Final X1 Outdoor Router DC power connection completed; proceed to step 3.	
3.	Lock the opposite end of the DC power cord into the Power Module.	

5.12 System Power Up

The X1 Outdoor Router can only be powered directly from the Power Module's DC power output connector. iDirect recommends that the chassis of the Power Module be powered from a low noise, low transient power source.

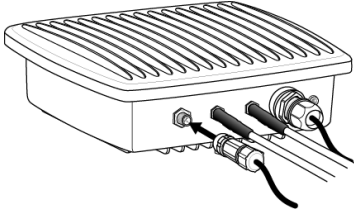
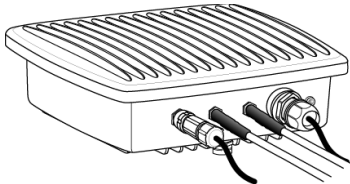
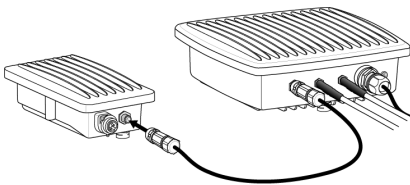
The power cord is specific to the needs of the installation site. Only the mating connector is supplied by iDirect and is referred to, in this manual, as the "power gland".



CAUTION: Install power on a GFI (Ground Fault Interrupter) protected circuit.



CAUTION: Improper power source rating, excessive noise or transients, or undersized circuit breaker will result in service interruption.



CAUTION: If power must be removed from the chassis, the power cord must be disconnected, first.



CAUTION: Direct connections to the prime power source should only be made by a properly licensed electrician. Installation must meet applicable electrical codes.



CAUTION: Do not connect or disconnect the Tx or Rx IFL cable while the satellite router is powered on; this action may result in damage to the BUC, LNB, and/or X1 Outdoor Router.

AVERTISSEMENT: Ne pas connecter ou déconnecter les câbles « Tx IFL » ou « Rx IFL » quand le routeur X1 est sous tension, sous risque de dommage au BUC, au LNB, et/ou au routeur X1.

5.12.1 Checking Conditions Before System Power Up

Verify that an Ethernet cable connects the LAN port of the PC/laptop to the LAN port of the X1 Outdoor Router.

The X1 Outdoor Router operates in temperatures above -40° F (-40° C), see [Section 5.12.3, Cold Temperature Power Up on page 48](#) for starting in extremely cold temperatures.

5.12.2 Normal Temperature Power Up

For low temperature, -13° F (-25° C) and under, power up, go to [Section 5.12.3, Cold Temperature Power Up on page 48](#).

After checking the setup as outlined in [Section 5.12.1, on page 48](#), power up the X1 Outdoor Router as follows:

- Connect the iDirect supplied 2 meter DC power cable from the Power Module to the 4-pin power connector on the X1 Outdoor Router
- Plug external power supply cord into the power source
- There is a weather sealed power LED indicator on the right side of the Ethernet connector. When power is detected and the X1 Outdoor Router is powered up, the LED light is solid red. If no power is detected, the LED is off



NOTE: The Web Interface (Web iSite) always shows 4 simulated LEDs, although the outdoor unit has a single **POWER LED**.

5.12.3 Cold Temperature Power Up

An X1 Outdoor Router operates in outdoor ambient temperatures as low as -40° F (-40° C). However, if the satellite router is powered off long enough for the internal temperature to fall below -13° F (-25° C) then the modem must warm up before it will become operational.

After checking the setup as outlined in [Section 5.12.1, on page 48](#), power up the X1 Outdoor Router as follows:

- Connect the iDirect supplied 2 meter DC power cable from the Power Module to the 4-pin power connector on the X1 Outdoor Router
- Plug external power supply cord into the power source

- The warm-up period for the X1 Outdoor Router depends on the internal modem temperature measured at the time it is powered on; [Table 5-5](#) provides the warm-up periods

Table 5-5. X1 Outdoor Router Warm-Up Periods

Internal Temperatures	Warm-Up Period
-13° F to -31° F (- 25° C to -35° C)	1.5 minutes
-31° F to -40° F (-35° C to -40° C)	4.0 minutes

- During the long warm-up or short warm-up, the Web interface (Web iSite) will show the **POWER LED** as GREEN and the other LEDs will be yellow; the satellite Rx state on the dashboard shows “Waiting for DEMOD Lock” during the warm-up; the Dashboard of the Web Interface will display a temperature reading, so, this can be observed during warm-up to ensure the temperature is increasing
- Once warm-up has completed, the Web Interface (Web iSite) simulation of LEDs will change as the remote goes through the steps to become acquired in the network; see the [Related Documents on page xiii](#) section for guidance to other helpful manuals



NOTE: While “on”, the unit will operate without any interruptions down to a -40° C (-40° C) outdoor ambient temperature.



NOTE: The Web Interface (Web iSite) always shows 4 simulated LEDs, although the outdoor unit has a single **POWER LED**.

5.13 Preparing the PC/Laptop for Connection to the X1 Outdoor Router

See [Section 3.2, X1 Outdoor Router Interfaces on page 15](#) for more information about the interface connectors.

Ensure that the PC/laptop:

- Has an IP address that is on the same subnet of the X1 Outdoor Router
- Includes a Network Interface Card (NIC) connected with a CAT 5 cable to the 10/100 LAN port of the X1 Outdoor Router
- Has a Web browser installed

5.14 LED Status

The X1 Outdoor Router has a single LED light on the front panel signifying that the power is either on or off, with a solid red LED status if “on”. However, the Web Interface software (Web iSite) displays a detailed status interpretation with a simulated panel of four LED status indicators. [Section 5.14.1, on page 50](#) and [Section 5.14.2, on page 50](#) describe the functions and display indicators for the physical front panel LED and the four virtual LEDs displayed in the Web Interface software, respectively.

5.14.1 Front Panel Power Indicator

A single LED on the front panel of the X1 Outdoor Router displays power status as described in table [Table 3-3 on page 16](#), see LED labeled “POWER”, solid red color indicates proper power.

5.14.2 Web Interface LED Status Indicators

For diagnostic purposes, the Web Interface (see [Related Documents on page xiii](#), *iDX Web iSite User Guide*) software LED displays four simulated “LED” indicators. The four software interpreted “LED” indicators are described in [Table 3-3 on page 16](#) and summarized as follows:



NOTE: The LED displayed colors (red, yellow, green) indicate the state of the X1 Router and are documented in the *iDX Web iSite User Guide*, *iDX Satellite Router Installation and Commissioning Guide*, and *iDX Release Notes*. The definitions of the states may be software version dependent.

- RX LED indicates the transmitter status
- TX LED indicates the receiver status
- NET LED indicates the network acquisition status
- POWER LED indicates whether the unit is powered on or off

5.15 Configuring the X1 Outdoor Router

When the X1 Outdoor Router is physically installed, the firmware and configuration of the satellite router need to be completed. For instructions on how to do this, refer to the *iDX Satellite Router Installation and Commissioning Guide*. To download the guide, go to <http://tac.idirect.net> and click **Satellite Routers**.

6 Maintenance and Troubleshooting

This chapter describes maintenance procedures necessary for ensuring the correct functioning of the X1 Router at a VSAT location.

This chapter contains the following sections:

- [Section 6.1, Safety Guidelines to Observe During Servicing on page 51](#)
- [Section 6.2, Maintaining the X1 Router on page 52](#)
- [Section 6.3, Maintaining the X1 Outdoor Router on page 53](#)
- [Section 6.4, Troubleshooting on page 54](#)
- [Section 6.5, Repacking the X1 Router on page 54](#)

6.1 Safety Guidelines to Observe During Servicing

When an X1 Router requires service, observe the safety guidelines in this section:

- Always remove or disconnect ALL power connections before installing or removing a chassis
- Keep the staging area clear and free of dust during and after installation
- Keep tools, X1 Router components, and shipping boxes away from walkway area
- Do not overload wall outlets, extension cords, or integral convenience receptacles as this can result in a risk of fire or electrical shock
- Cables – Never use any other RF cable than what is supplied or recommended by iDirect
- Cleaning – Do not use liquid cleaners or aerosol cleaners; use a cloth for wiping up dust

6.1.1 Servicing



WARNING: This unit is not serviceable. Return unit to provider for all servicing issues.

ATTENTION: Cette unité n'est pas réparable sur site. Renvoyer au fournisseur pour tout réparation.

Do not attempt to service the X1 Router internal assemblies, as opening and removing covers may expose personnel to dangerous voltages or other hazards. There are no user serviceable parts inside. Opening the X1 Router or Power Module will void the warranty. Refer all servicing to qualified service personnel.

6.1.2 Conditions Requiring Service

Unplug the X1 Router from the power source and refer servicing to qualified service personnel under the following conditions:

- When the power supply cord or plug is damaged
- If the X1 Router does not operate normally when following the operating instructions
- If the X1 Router has been dropped or if the chassis has been damaged
- When the X1 Router exhibits a distinct change in performance

6.2 Maintaining the X1 Router

The X1 Router requires basic maintenance to keep it running efficiently and to prolong its life.

Typically, the only maintenance needed to be performed on the unit, without explicit directions from iDirect, is to maintain the temperature of the X1 Router and keep its external areas free from dust or dirt. There are no user-serviceable parts within the X1 Outdoor Router. Do not attempt to repair/replace a malfunctioning or defective component/module. Doing so may void the warranty.



CAUTION: This unit is not serviceable. Return unit to provider for all servicing issues.

ATTENTION: Cette unité n'est pas réparable sur site. Renvoyer au fournisseur pour tout réparation.

6.2.1 Temperature Control

The X1 Router has a built-in temperature sensor. The temperature sensor measures the actual circuit board temperature. If the board temperature exceeds a defined threshold, the X1 Router alerts the NMS about the high temperature condition. See [Table 2-1 on page 3](#), for the proper temperature range.

Various conditions can cause the satellite router chassis to have an elevated internal temperature, such as:

- Objects blocking the enclosure vents
- Dust accumulated on the enclosure or the vent
- Ambient temperature elevated beyond the specified limits

6.2.2 Dust Removal

A dusty environment requires frequent maintenance. With the unit powered down, use a slightly damp cloth with the excess moisture wrung out (not a saturated, dripping-wet cloth) to wipe away the dust that collects on the outside of the enclosure. Do not use liquid cleaners or aerosol cleaners. Use a cloth for wiping up dust.

6.2.3 90 Day Regular Maintenance

The X1 Router should have the following procedures performed every 90 days:

- Make sure that no objects are blocking the core protective vents
- If there are objects blocking the core protective vents, remove them safely, so, there is approximately least 6 inches (12 cm) clearance
- Make sure that the ambient temperature remains within the specified limit

6.3 Maintaining the X1 Outdoor Router

The X1 Outdoor Router requires basic maintenance to keep it running efficiently and to prolong its life.

Typically, the only maintenance needed to be performed on the unit, without explicit directions from iDirect, is to maintain the temperature of the X1 Outdoor Router and keep its external areas free from dust, dirt, and debris. There are no user-serviceable parts within the X1 Outdoor Router. Do not attempt to repair/replace a malfunctioning or defective component/module. Doing so may void the warranty.



CAUTION: This unit is not serviceable. Return unit to provider for all servicing issues.

ATTENTION: Cette unité n'est pas réparable sur site. Renvoyer au fournisseur pour tout réparation.

6.3.1 Temperature Control

The X1 Outdoor Router has a built-in temperature sensor. The temperature sensor measures the actual circuit board temperature. If the board temperature exceeds a defined threshold, the X1 Outdoor Router alerts the NMS about the high temperature condition. See [Table 2-5 on page 7](#), for the proper temperature range.

Various conditions can cause the satellite router chassis to have an elevated internal temperature, such as:

- Dust or debris accumulated on the enclosure
- Ambient temperature elevated beyond the specified limits

6.3.2 90 Day Regular Maintenance

The X1 Outdoor Router should have the following procedures performed every 90 days:

- Walk around the area where the router and power supply are installed and make sure nothing is impeding the units
- Make sure weatherproofing on the cabling (tape) is in good condition
- Make sure that the ambient temperature remains within the specified limits

6.4 Troubleshooting

Table 6-1 describes the most common X1 Router troubleshooting events and actions to take. Consult with the iDirect TAC when considering a reset. Reset functions are described in [Appendix E, X1 Reset on page 71](#).

Table 6-1. Troubleshooting Events and Actions to Take

Event	Action
Router not functioning	Check status LEDs. Compare LEDs to Table 3-1, X1 Router Front Panel LED Indicators on page 12
POWER LED OFF (No power)	<ul style="list-style-type: none"> • Verify power connection • Test power to determine if there is power to the power module
POWER LED ON and not functioning	Test power Check other status LEDs. Compare LEDs to Table 3-1, X1 Router Front Panel LED Indicators on page 12 .
Lost or forgot IP address of router and/or DHCP* (DHCP server) is disabled Dynamic Host Configuration Protocol	<ul style="list-style-type: none"> • Perform a Level 1 reset (Boot into Recovery mode) so that the X1 Router will have a known IP address of the default: 192.168.0.1 • Retrieve the options file (which will list the router's current IP address) and write down the current IP address • Reboot with a Level 0 reset, and connect with the current IP address • See Appendix E, X1 Reset on page 71 for more information on Reset
Router cannot be accessed by Web iSite	<ul style="list-style-type: none"> • Router may have a bad options file, settings, or software package • Perform a Level 1 reset (Boot [into Recovery mode]) and manually load the correct options file and the new software package that is appropriate • Reboot with a Level 0 reset to see if the issue is fixed • See Appendix E, X1 Reset on page 71 for more information on Reset

6.5 Repacking the X1 Router

If the X1 Router system is damaged, or if the chassis needs to be moved to another location, the unit needs to be repacked in the original shipping boxes.

To repack the system:

1. Disconnect all cables.
2. Place the X1 Router inside the original foam cutout in the shipping box.
3. Properly seal the box with packing tape.

For warranty service, obtain a Return Material Authorization (RMA) number from the reseller or iDirect prior to shipping. Direct customers of iDirect, may contact the iDirect TAC directly to obtain an RMA number and shipping instructions. Follow the shipping instructions, complete the RMA form, and attach the form to the outside of the shipping box.

Appendix A Acronyms and Abbreviations

The list in this appendix is meant to be generic and may contain acronyms and abbreviations not found in this manual and some terms may not be defined based on industry standards of knowledge.

0...9

16APSK	Sixteen Amplitude and Phase Shift Keying
8PSK	Eight Phase Shift Keying

A

A-TDMA	Adaptive Time Division Multiple Access
ABS	Automatic Beam Switching
AC	Alternating Current
ACM	Adaptive Coding and Modulation
ACS	Antenna Control System
AES	Advanced Encryption Standard
APSK	Amplitude and Phase-shift keying
AWG	American Wire Gauge
AZ	Azimuth

B

BB	BaseBand
BIM	Below-Decks Interface Module
BIST	Built-In Self-Test

BITE	Built-In Test Equipment
BPN	BUC Part Number
BPSK	Binary Phase Shift Keying
BSN	BUC Serial Number
BTP	Burst Time Plan
BUC	Block Up Converter

C

C/N	Carrier to Noise ratio
CBIT	Continuous Built In Test
CDR	Critical Design Review
CIR	Committed Information Rate
CPE	Customer Premise Equipment
CPU	Central Processing Unit
CRC	Cyclic Redundancy Check
CSA	Canadian Space Agency

D

DAC	Digital to Analog Converter
dB	decibel
dB _i	decibel isotropic
dB _m	decibel milli-Watt

dBW	deciBel Watt	G	
DC	Direct Current	G/T	Gain over Temperature
DDR	Double Data Rate	GHz	GigaHertz
DHCP	Dynamic Host Configuration Protocol	GPIO	General-Purpose Input/Output
DNS	Domain Name Service	GPS	Global Positioning System
DVB-S2	Digital Video Broadcasting over Satellite, Second Generation	H	
		HCP	High-Capacity Payload
E		I	
EIRP	Effective Isotropic Radiated Power	IBIT	Initiated Built In Test
Eb/NO	Bit Energy to Noise Power Spectral Density ratio	ICD	Interface Control Document
EEPROM	Electrically Erasable Programmable Read-Only Memory	ICMP	Internet Control Message Protocol
EL	Elevation	iDX	Evolution Software System
EMC	ElectroMagnetic Compatibility	IDU	Indoor Unit
EMI	ElectroMagnetic Interference	IEC	International Electrotechnical Commission
ETSI	European Telecommunications Standards Institute	IFL	Inter-Facility Link
		IF	Intermediate-frequency
		IP	Ingress Protection
F		IP	Internet Protocol
FCC	Federal Communication Commission	IR	Information Rate
FEC	Forward Error Correction	J	
FID	Functional ID	K	
FMECA	Failure Mode Effects Criticality Analysis	kbps	kilobit per second
FPGA	Field Programmable Gate Array	kHz	kilohertz
FS	Functional Specification	KRFU	Ku/Ka-band Radio Frequency Unit

ksps	kilosymbol per second	OAE	Outside Antenna Equipment
L		ODE	Outdoor Equipment
LAN	Local Area Network	ODU	Outdoor Unit
LDPC	Low-Density Parity Coding	OEM	Original Equipment Manufacturer
LED	Light Emitting Diode	OMT	Orthogonal-Mode Transducer
LNB	Low Noise Block Converter	OpenAMIP	Open Antenna-Modem Interface Protocol
LOS	Loss of Signal	OTA	Over The Air
LRU	Line-Replaceable Unit	OTP	One Time Programmable
M		P	
Mbps	Megabits per second	PA	Power Amplifier
Mcps	Megachips per second	PAST	Person-Activated Self-Test
MES	Mobile Earth Station	PCB	Printed Circuit Board
MF-TDMA	Multi-Frequency TDMA	PC	Personal Computer
MHz	Megahertz	PDR	Preliminary Design Review
MID	Manufacturer ID	PLL	Phased Locked Loop
MIL-STD	US Military Standard	PSK	Phase Shift Keying
MODCOD	Modulation and Coding	PSU	Power Supply Unit
Msp	Mega Symbols per Second	Q	
MTBF	Mean Time Between Failures	QEF	Quasi Error Free
MTBUR	Mean Time Between Unscheduled Removals	QoS	Quality of Service
N		QPSK	Quadrature Phase Shift Keying
NAND	Not AND	R	
NF	Noise Figure	RF	Radio Frequency
NOR	Not OR	RGMI	Reduced Gigabit Media Independent Interface
NMS	Network Management System	RMS	Root Mean Square
O			

RoHS	Restriction of Hazardous Substances	UDP	Universal Data Protocol
ROM	Read-Only Memory	UL	Underwriters Laboratories
RSSI	Receive Signal Strength Indication	V	
RTP	Real-Time Protocol	VAC	Volts Alternating Current
Rx or RX	Receive	VDC	Volts Direct Current
S		VSAT	Very Small Aperture Terminal
SAS	Satellite Access Station	W	
SCPC	Single Channel Per Carrier	WFQ	Weighted Fair Queuing
SGMII	Serial Gigabit Media Independent Interface	WGS	Wideband Global SATCOM
SIM	Subscriber Identity Module	X	
SNR	Signal to Noise Ratio	X	
SRS	Systems Requirement Specification	X	
SRU	Shop Replaceable Unit	Z	
SSB	Single Side Band		
T			
TCP	Transmission Control Protocol		
TDMA	Time Division Multiple Access		
TFI	Terminal Functional ID		
TMI	Terminal Manufacturer ID		
TPCFEC	Turbo Product Code FEC		
TPN	Terminal Part Number		
TSN	Terminal Serial Number		
TTC	Terminal Transmit Control		
Tx or TX	Transmit		
U			

Appendix B Tools Needed



NOTE: The tools intended for use in this section are intended to be generic. Equipment should be installed per manufacturer's requirements specific to the brands preferred.

This section describes tools needed for X1 Router installation.

B.1 Indoor Coax Installation Tools Needed

[Table B-1](#) specifies recommended tools and supplies for a typical indoor installation and [Figure B-1 on page 62](#) shows the tools.

Table B-1. Recommended Installation Tools and Equipment for Indoor Coax

Quantity	Tool
1	Number 2 Phillips screwdriver Figure B-1
1	F-Connector crimper or Compression Tool Figure B-1
1	RG-6 Coax Stripper, see Figure B-1
1	Coax / Wire Cutter, see Figure B-1
length as needed	RG-6 or RG-11 solid copper conductor coax outdoor rated cable

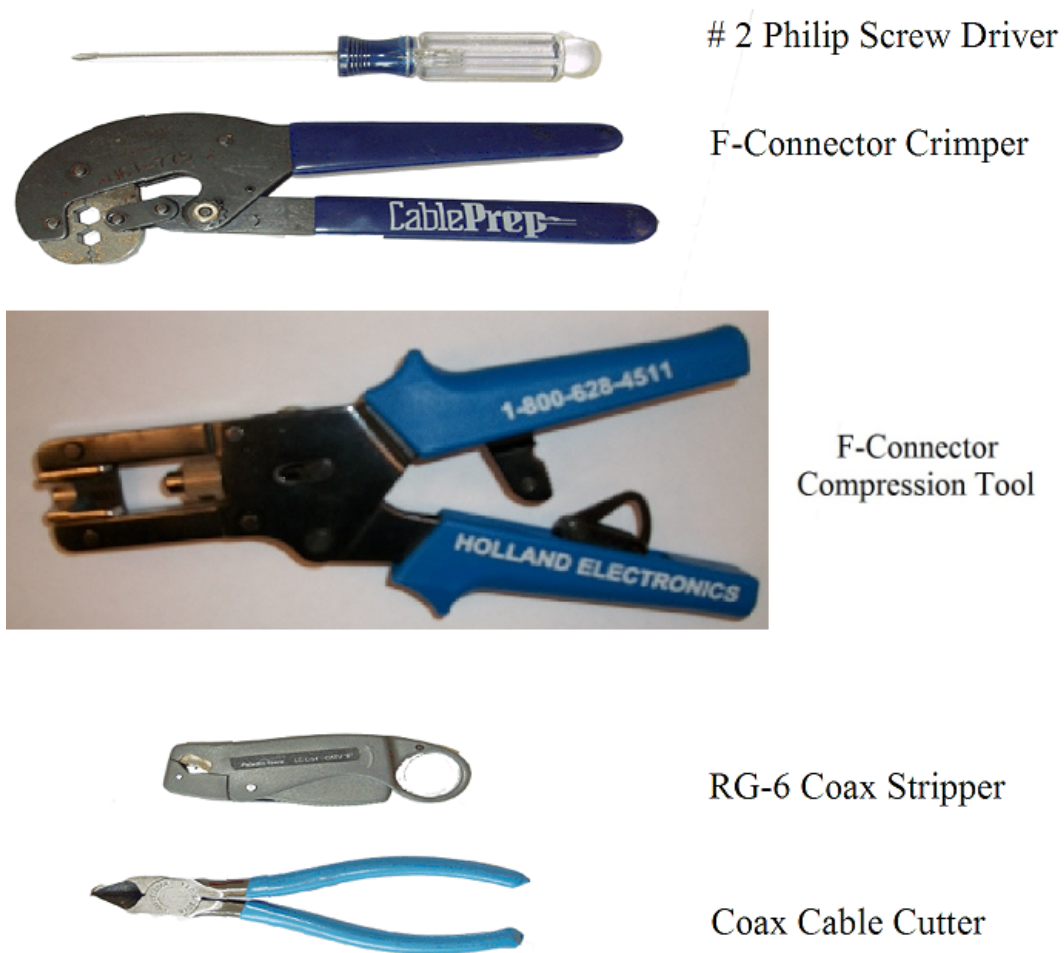

Figure B-1. Installation Tools

B.2 Outdoor (ODU) Coax Installation Tools Needed

Table B-2 specifies the tools that are included with the order and Figure B-1 and Table B-3 specify recommended tools and supplies for a typical installation.

Table B-2. Tools Included in the order

Quantity	Tool
1	1.5 mm Allen wrench

Table B-3. Recommended Installation Tools and Equipment for Outdoor Coax

Quantity	Tool
1	Number 2 Phillips screwdriver (for rack mounting)
1	F-Connector Compression Tool, such as: Holland Compression Tool 1855, see Figure B-1 on page 62
1	RG-6 Coax Stripper, see Figure B-1 on page 62
1	Coax / Wire Cutter, see Figure B-1 on page 62
1	SOJW 18AWG (OD (outdoor) must comply with AC connector), AC Power Cable Where: S - Service Grade, O - Oil Resistant, a single O means only the outer jacket is oil resistant, J - Hard Service, W - Outdoor rated, includes sunlight resistant jacket and wet location rated conductors, 18AWG - 18 American Wire Gauge Reference http://en.wikipedia.org/wiki/American_wire_gauge
2	F-type weatherproof outdoor connectors with weatherproofing gasket (O-ring), such as: Holland SLCU6-Q0, see labeled figures A and B in Figure C-5, Compression fitting F-Type Weatherproof Plugs and Tool on page 68
1	RG-6 or RG-11 solid copper conductor coax outdoor rated cable
1	3M Temflex™ 2155 Rubber Splicing Tape covered with Scotch® Super 33+, recommended to weatherproof connectors, if connectors are not weatherproof certified or according to manufacturer's recommendations
1	RJ-45 connector
1	DB-9 to RJ-45 Adapter
1	Length of outdoor rated a shielded outdoor Ethernet LAN
1	(Optional) Wrench for securing/un-securing the plastic sealing nut designated as part A in Table 5-1, RJ 45 LAN Ethernet Cable Installation Steps on page 41 .

Outdoor (ODU) Coax Installation Tools Needed

Appendix C Coax Cable Preparation



NOTE: The procedures in this section, for preparing outdoor coaxial cables, are meant to be generic. Cables and connectors should be installed per manufacturer's requirements specific to the brands preferred. In general, specific and detailed instructions are for RG-6 cables and connectors, only.

Use high quality coaxial outdoor cable to connect the X1 Series Satellite Router to the Outdoor Unit (ODU) equipment. iDirect recommends that a solid copper center conductor, coaxial cable be used with a minimum of 60% + 40% braid and double foil shield to connect the equipment, such as:

- RG-6 – 0.04 inch (1 mm), outdoor rated, Quad Shielded, solid bare copper center conductor, for cable lengths less than or equal to 225 feet (68.5 meters)
- RG-11 – 0.064 inch (1.6 mm), outdoor rated, Quad Shielded, solid bare copper center conductor, for cable lengths less than or equal to 400 feet (121.9 meters)

Before connecting the cables, connectors on each end must be installed.

The center conductor must be straight and extend 1/8 inch (3.2 mm) beyond the end of the F-connector, and the connector should be securely crimped to the cable.



NOTE: iDirect does not recommend using RG-59 with solid bare copper center conductor. RG-6 or RG-11 Quad Shield or other outdoor quality, 75-ohm type of coax can be used.

If different types of coaxial cable are used other than the recommended quad shield RG-6, the following problems can occur:

- **Co-channel Interference** - If signals at the same frequency are carried on long, parallel runs of coaxial cable (for example, in cable trays, or riser) interference can occur between the signals
- Higher quality cable helps to prevent this with better shielding. Co-channel interference causes degradation and higher packet loss rate
- **Good return loss** - High quality cable and correct connectors help ensure an optimal return loss of 10 dB or more

Excessive DC Resistance - will result in excessive voltage drop across the IFL cable. Hence, the voltage at the BUC may be too low to operate properly.



NOTE: [Appendix B, Tools Needed on page 61](#) lists all of the recommended tools for terminating coax cables.

To terminate the cables with F-Type connectors:

1. Cut off each end of the coax cable squarely, using the proper cable cutter as shown in [Figure C-1](#).



Figure C-1. Coax Cable Cutting Technique



WARNING: Wear protective eye wear while cutting cables and terminating connectors.

The center conductor must be straight and cylindrical without any burrs. Failure to do so can damage the satellite router, BUC, and/or LNB input connector.

2. Remove the jacket material and foam insulation according to the length defined under **Length A** in [Table C-1](#). For RG-6, use a two-step Coax Stripper such as the LC-CST 1257 from Paladin Tools.

Table C-1. Coax Trim Dimensions

	Length A (inch (mm))	Length B (inch (mm))	Length C (inch (mm))
RG-6	5/8 (15.9)	1/4 (6.4)	3/8 (9.5)
RG-11	13/32 (10.3)	3/32 (2.4)	13/32 (10.3)

3. Remove any foil in the braid as shown in [Figure C-2](#).



Figure C-2. Cutting Technique for Removing Foil in the Braid

4. Fold the braid back over the jacket and trim the braid to the length as defined under **Length C** in [Table C-1 on page 66](#) and shown in [Figure C-3](#).

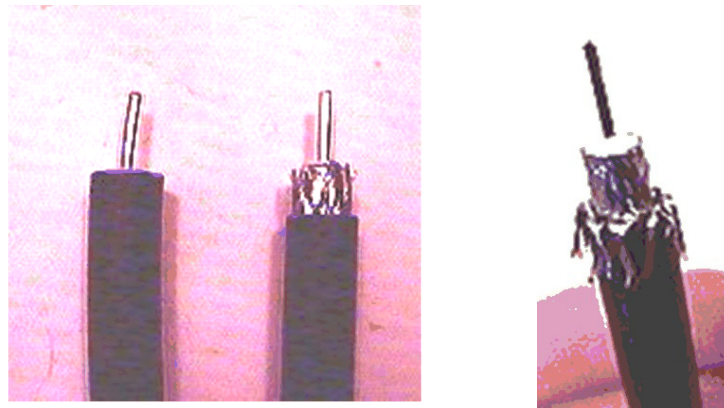

Figure C-3. Folding the Braid

5. Flare the inner, outer braids and the outer foil shield only. Do not flare the inner foil shield (last foil around dielectric).
6. (If using a coax stripper, skip this step.) Being careful not to cut into the copper of the center conductor, remove the foil and cut the dielectric to the length shown under **Length B** in [Table C-1 on page 66](#). Remove any dielectric residue.
7. If the conductive foil is burred, then smooth out the burr so that the edge (area where the dielectric material was removed) is smooth and provides a lead-in for the connector mandrel.
8. Install the RG-6 connector compression sleeve, or mandrel, (top left (A) in [Figure C-4 on page 68](#)) over foil and underneath the braid. A good, weatherproof outdoor connector mandrel should have a visible O-Ring (bottom right (B) [Figure C-4 on page 68](#)).



NOTE: The white colored inner dielectric insulation should be flush with the inner rear surface of the connector. Refer to the picture on the right (C) in [Figure C-4 on page 68](#) for an RG-6/RG-11 termination.

9. Since the RG-11 connector has a built-in center pin, ensure that the coax center pin makes contact to the internal seizing pin of the connector. Refer to [Figure C-3](#).

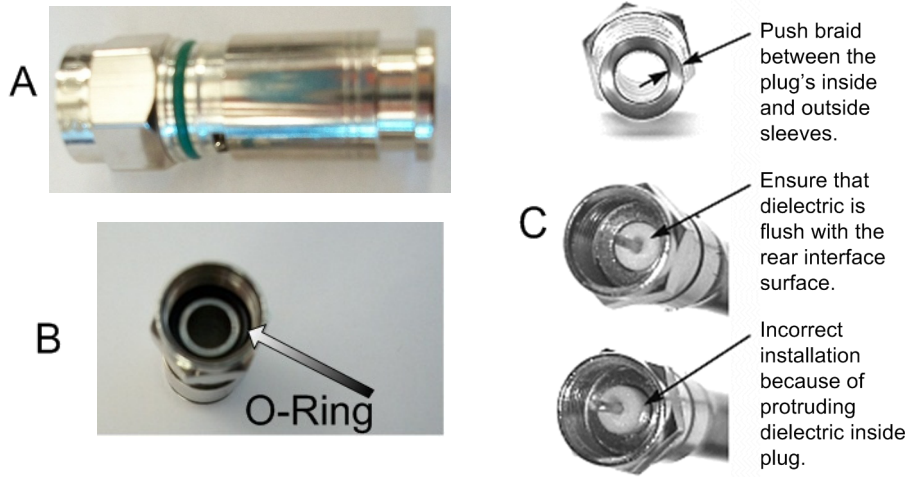

Figure C-4. Attaching the Compression fitting F-type Connector

10. Finish connecting the cable to the connector with the compression tool connector, such as Holland Compression Tool 1855 as shown in [Figure C-5](#).



Figure C-5. Compression fitting F-Type Weatherproof Plugs and Tool

11. Inspect and ensure that the copper center conductor only protrudes 1/8 inch (3.2 mm) nominally beyond the rim of the F-connector. Trim if necessary.



CAUTION: The center conductor length must be a minimum of 1/16 inch (1.6 mm) to a maximum of 1/8 inch (3.2 mm) protrusion beyond the rim of the F type connector. It must be straight and cylindrical without any burrs at the end. Failure to follow this technique could result in damage to the satellite router, BUC, LNB connector and/or possible intermittent service.

Appendix D Ethernet RJ45 Pinouts



NOTE: iDirect recommends a shielded outdoor Ethernet LAN cable be bought commercially to connect the X1 router to the LAN hub or switch.

A shielded Ethernet LAN Cable is a straight through cable typically used for connection to a PC. The X1 Router is capable of Universal Cable Recognition or auto-MIDX (auto-sensing) and will connect to a PC with the straight through Ethernet cable for Web iSite use.

Either crossover or straight through cables may be used with the X1 Router. It is not necessary for the PC to auto-sense. The X1 Router LAN/Ethernet port pinouts are shown in [Figure D-1](#) and the pinouts described in [Table D-1](#).

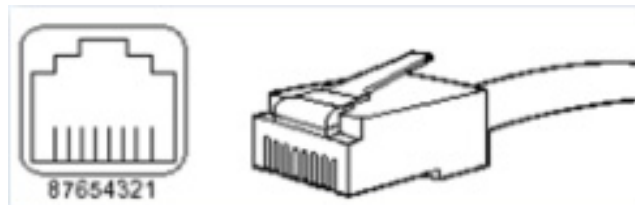

Figure D-1. RJ-45 Cable Connectors, Plug and Receptacle

Table D-1. Ethernet Port Pinouts

RJ-45 Pin	Description
1	Tx+
2	Tx-
3	Rx+
6	Rx-

The LAN port is normally assigned to the WAN (towards the VPN). Its IP address is the next hop for the VPN. See [Appendix E](#) for the IP address.



Appendix E X1 Reset

The X1 Router has two types of reset functions: Level 0 and Level 1. Each type has a different effect on the router. Contact the iDirect TAC center for more information.



NOTE: This section references Web iSite. Refer to the *iDX Web iSite User Guide* for more information. It is good practice to clear browser history, and turn off Web page caching, before accessing Web iSite.

E.1 Level 0 Reset

Level 0 reset provides a basic reset function with the following features:

- Initiated by:
 - Router powering up
 - Briefly pressing the reset button and not keeping it pressed for more than 1 second, see [Figure 3-2, X1 Indoor Router Rear Interface Connectors on page 14](#) and [Figure 3-3, X1 Outdoor Router Panel on page 16](#) for reset button locations
 - In Web iSite select the File Management menu > Restart Device > Restart
- Used to boot to a newly-loaded software image and configuration
- Recovery: recover by briefly pressing the reset button again, for not more than 1 second, or cycle the power off, then on

E.2 Level 1 Reset

Level 1 reset provides a means of returning the router to factory default settings.

Level 1 reset features:

- Initiated by:
 - Pressing the reset button and keeping it pressed for more than 8 seconds, see [Figure 3-2, X1 Indoor Router Rear Interface Connectors on page 14](#) for the reset button location
 - When booting into Factory Default Mode, neither the user software package nor the options files are deleted; however, they are ignored temporarily. When booting back into normal operational mode, the user software package will run and use the setting in the options files.
- Recovery: Perform a Level 0 reset, do not change any settings. Router should reboot with last known configuration.

- Use in troubleshooting: see [Section 6.4, Troubleshooting on page 54](#)

iDirect

13861 Sunrise Valley Drive, Suite 300

Herndon, VA 20171-6126

+1 703.648.8000

+1 866.345.0983

www.idirect.net

Advancing a Connected World