

Type 960 .96 Meter Class I and II Antenna System

Type 123 1.2 Meter Class I and II Antenna System

with Factory Assembled Az/El Cap Mount

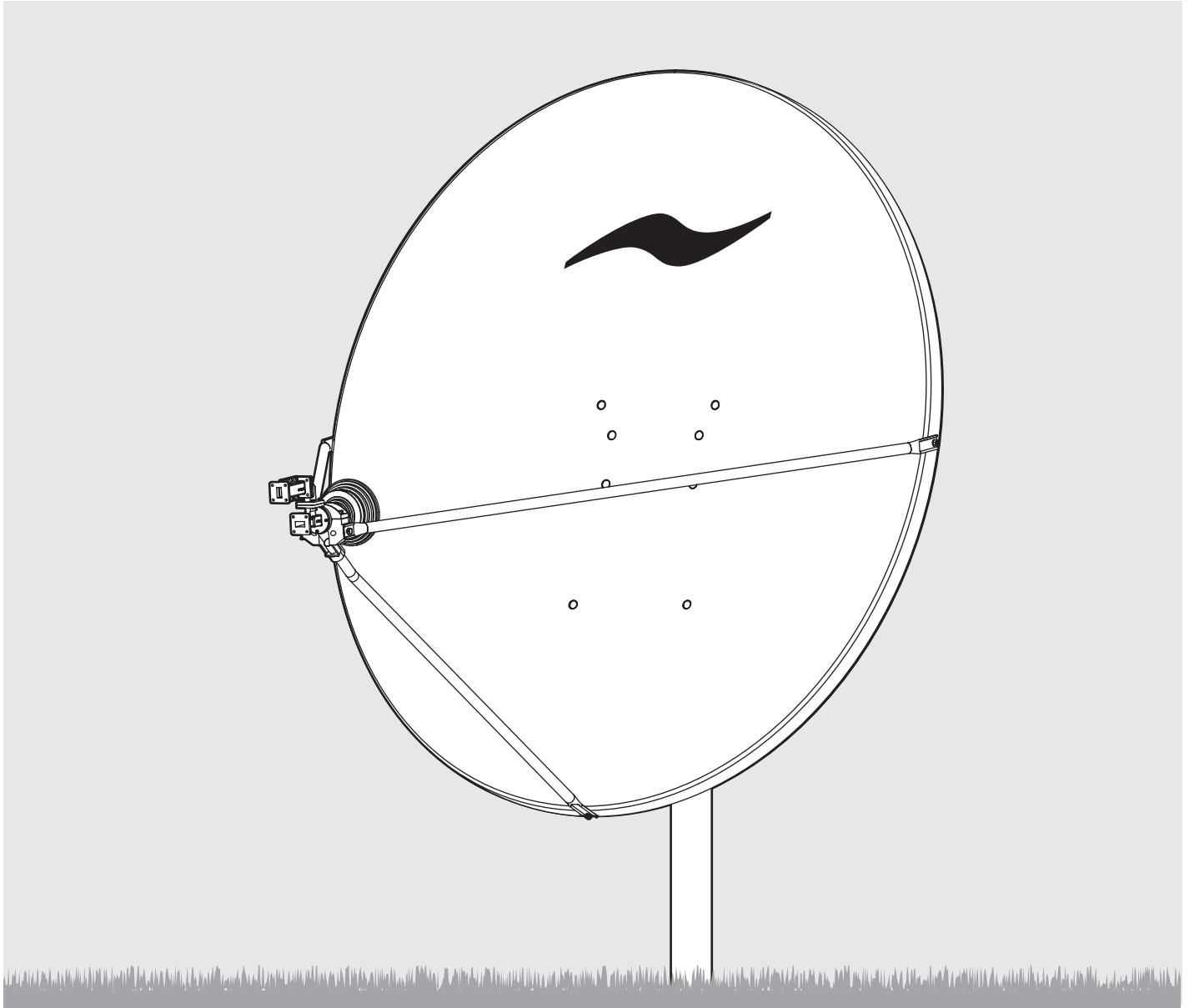

ASC Signal Corporation
1315 Industrial Park Drive
Smithfield, NC 27504

Telephone: +1-919-934-9711

Internet: www.ascsignal.com

Printed in U.S.A.

05/08 8000842-01 Rev D

MANUAL REVISION HISTORY

DATE	DESCRIPTION	REVISION
08/06	ECN 9007484	Rev B
11/07	5075515	Rev C
05/08	5078314	Rev D

WARRANTY

ASC Signal CORPORATION VERY SMALL APERTURE TERMINAL (VSAT) PRODUCTS TWELVE (12) MONTH LIMITED WARRANTY

Seller warrants that all ASC Signal manufactured VSAT products are transferred rightfully and with good title; that they are free from any lawful security interest or other lien or encumbrance unknown to Buyer. Seller also warrants that for a period of twelve (12) months from the date of shipment from Seller's factory, all its VSAT products shall be free from defects in material and workmanship which arise under proper and normal use and service. Buyer's exclusive remedy hereunder is limited to Seller's correction (either at its plant or at such other place as may be agreed upon between Seller and Buyer) of any such defects by repair or replacement at no cost to Buyer, except for the costs of any transportation in connection with the return of the defective VSAT products to be replaced or repaired, and the costs to remove and/or reinstall the products, which shall be borne by Buyer. The limited warranty period shall not be extended beyond its original term with respect to any part or parts repaired or replaced by seller hereunder.

This warranty shall not apply to VSAT products which (i) have been repaired or altered in any way so as to affect stability or durability, (ii) have been subject to misuse, negligence or accident, (iii) have been damaged by severe weather conditions such as excessive wind, ice, storms, lightning, or other natural occurrences beyond Seller's control; (iv) have presented damages, defects or nonconformances caused by improper shipping, handling or storage, and (v) have not been installed, operated or maintained in accordance with Seller's instructions.

Buyer shall present any claims along with the defective VSAT product(s) to Seller immediately upon failure. Non-compliance with any part of this warranty procedure may invalidate this warranty in whole or in part.

SELLER MAKES NO WARRANTY, EXPRESS OR IMPLIED, OTHER THAN AS SPECIFICALLY STATED ABOVE. EXPRESSLY EXCLUDED ARE ANY IMPLIED WARRANTIES OF MERCHANTABILITY OR FITNESS FOR A PARTICULAR PURPOSE. THE FOREGOING SHALL CONSTITUTE ALL OF SELLER'S LIABILITY (EXCEPT AS TO PATENT INFRINGEMENT) WITH RESPECT TO THE VSAT PRODUCTS. IN NO EVENT SHALL SELLER BE LIABLE FOR ANY LOSS OF PROFITS OR REVENUE, LOSS OF USE, INTERRUPTION OF BUSINESS, OR INDIRECT, SPECIAL, CONSEQUENTIAL OR INCIDENTAL DAMAGES OF ANY KIND AS A RESULT OF THE USE OF THE PRODUCTS MANUFACTURED BY SELLER, WHETHER USED IN ACCORDANCE WITH THE INSTRUCTIONS OR NOT. UNDER NO CIRCUMSTANCES SHALL SELLER'S LIABILITY TO BUYER EXCEED THE ACTUAL SALES PRICE OF THE VSAT PRODUCTS HEREUNDER.

In some jurisdictions, Buyer may have other rights under certain statutes that may imply non-excludable warranties. No representative is authorized to assume for Seller any other liability in connection with the VSAT products.



DO NOT DISCARD CONTENTS

The product in this packaging was placed in the market after August 13, 2005. Its components must not be discarded with normal municipal or household waste.

Contact your local waste disposal agency for recovery, recycling, or disposal instructions.

WARNINGS

LAW: Installation and installer must meet local codes and ordinances regarding safety! Installation of this product should be performed only by a professional installer and is not recommended for consumer Do-It-Yourself installations.

DANGER: WATCH FOR WIRES! Installation of this product near power lines is extremely dangerous and must never be attempted. Installation of this product near power lines can result in death or serious injury! For your own safety, you must follow these important safety rules. Failure to follow these rules could result in death or serious injury

1. Perform as many functions as possible on the ground
2. Watch out for overhead power lines. Check the distance to the power lines before starting installation. Stay at least 6 meters (20 feet) away from all power lines.
3. Do not install antenna or mast assembly on a windy day.
4. If you start to drop antenna or mast assembly, move away from it and let it fall.
5. If any part of the antenna or mast assembly comes in contact with a power line, call your local power company. **DO NOT TRY TO REMOVE IT YOURSELF!** They will remove it safely.
6. Make sure that the mast assembly is properly grounded.

WARNING: Assembling dish antennas on windy days is extremely dangerous and must never be attempted. Due to the surface area of the reflector, even slight winds create strong forces. For example, this antenna facing a wind of 32 km/h (20 mph) can undergo forces of 269 N (60 lb). **BE PREPARED TO SAFELY HANDLE THESE FORCES AT UNEXPECTED MOMENTS. ATTEMPTING TO ASSEMBLE, MOVE OR MOUNT A DISH ON WINDY DAYS COULD RESULT IN DEATH OR SERIOUS INJURY.** ASC Signal is not responsible or liable for damage or injury resulting from antenna installations.

WARNING: Antennas improperly installed or installed to an inadequate structure are very susceptible to wind damage. This damage can be very serious or even life threatening. The owner and installer assumes full responsibility that the installation is structurally sound to support all loads (weight, wind and ice) and properly sealed against leaks. ASC Signal will not accept liability for any damage caused by a satellite system due to the many unknown variable applications.

PRE INSTALLATION CONSIDERATIONS

TOOLS REQUIRED:

Compass	13 mm Deep Socket (3/8" Drive)	10 mm Nut Driver	Torque Wrench
Clinometer	#1 or #2 Phillips Screwdriver	10 mm Socket (3/8" Drive)	9" Magnetic Level
3/8" Drive Ratchet Wrench	13 mm Combination Wrench	10 mm Combination Wrench	(2) 17 mm Open End Wrenches

ADDITIONAL INSTALLATION MATERIALS (Not Included with Antenna)

- Installation Mount (Ground Pole, King Post, Wall Mount or Roof Mount)
- Grounding Rod, Clamp & Grounding Block - As required by National Electric Code or local codes.
- Ground Wire - #10 solid copper or #8 aluminum as required by National Electric Code or local codes (length as required).
- RG-6 Coaxial Cables from antenna to indoor units.
- Concrete: See "Ground Pole" section for quantity
- M10 or #3 Rebar: See "Ground Pole" section for quantity. Deformed steel per ASTM A615, Grade 40 or 60.

SITE SELECTION

The first and most important consideration when choosing a prospective antenna site is whether or not the area can provide an acceptable "look angle" at the satellites. A site with a clear, unobstructed view is preferred. Also consider obstruction that may occur in the future such as the growth of trees. Your antenna site must be selected in advance so that you will be able to receive the strongest signal available. To avoid obstructions, etc., conduct an on-site survey with a portable antenna. The satellite antenna can be installed on a ground pole, wall/roof mount, or non-penetrating roof mount with 2-7/8" or 3" outside diameter mast. The chosen mount type should be assembled and in place before installing the antenna. Refer to instructions packed with mount for its proper installation. The mast pipe must be vertical and plumb to insure ease of alignment.

As with any other type of construction, a local building permit may be required before installing an antenna. It is the property owner's responsibility to obtain any and all permits.

Before any digging is done, information regarding the possibility of underground telephone lines, power lines, storm drains, etc., in the excavation area should be obtained from the appropriate agency.

Because soils vary widely in composition and load capacity, consult a local professional engineer to determine the appropriate foundation design and installation procedure. A suggested foundation design with conditions noted is included in this manual for reference purposes only.

GROUND POLE INSTALLATION

Pier Foundations

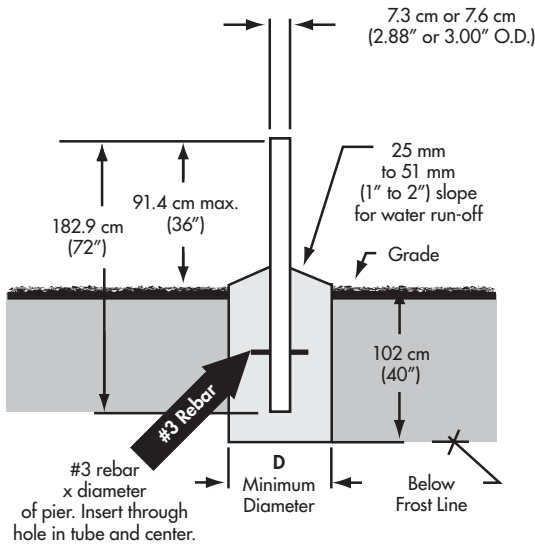

Deep Frost Line Foundations

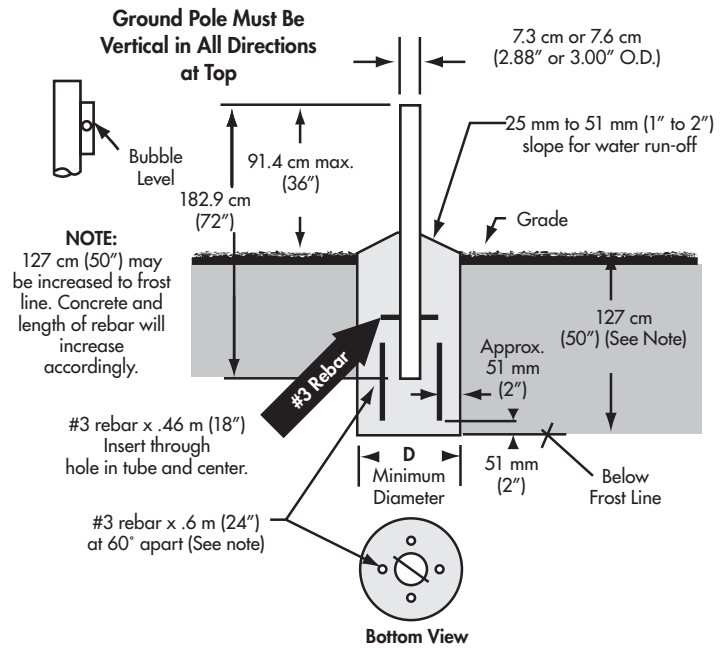

Pier Foundations

Deep Frost Line Foundations

	EXPOSURE B		EXPOSURE C		GROUND POLE	
	WIND VEL km/h (mph)	DIM D cm (in)	CONC VOL m ³ (ft ³)	DIM D cm (in)		CONC VOL m ³ (ft ³)
96 cm Antenna	161 (100)	25 (10)	0.05 (1.8)	38 (15)	0.12 (4.1)	A, B or C
	201 (125)	36 (14)	0.10 (3.7)	51 (20)	0.21 (7.4)	A, B or C
1.2 m Antenna	161 (100)	30 (12)	0.07 (2.5)	46 (18)	0.17 (6.0)	A, B or C
	201 (125)	43 (17)	0.15 (5.2)	61 (24)	0.30 (10.5)	A or C

POLE SPECIFICATIONS:

Ground Pole "A"	2-1/2 Schedule 40 Steel ASTM A53 Pipe (73 mm x 5 mm Wall/2.88" OD x .203" Wall)
Ground Pole "B"	3.0" OD x 9 Gauge (.148" Wall) Steel ASTM A501 Pipe (76 mm OD x 3.8 mm Wall)
Ground Pole "C"	2-1/2 Schedule 80 Steel ASTM A53 Pipe (73 mm x 7 mm Wall/2.88" OD x .276" Wall)

NOTE:

- Poles are not supplied (purchase locally to above specifications) and must be field drilled 5/8" diameter for M10 #3 rebar, 5.5 mm for self tapping grounding screw and (.218") for 1/4-20 self tapping grounding screw. Poles and screws must be galvanized or painted for protection.
- Pole and foundation design based on the following criteria:
 - Uniform building code Exposure B or C wind loading.
 - Vertical soil pressure of 13790 kPa (2000 pounds per square foot).
 - Lateral soil pressure of 2758 kPa (400 pounds per square foot).
 - Concrete compressive strength of 17.2 MPa (2500 pounds per square inch) in 28 days.
- See page 6 for grounding recommendations.

CAUTION: The foundation design shown does not represent an appropriate design for any specific locality. Soil conditions vary and may not meet design criteria given in Note 2. Consult a local professional engineer to determine your soil conditions and appropriate foundation.

The Az/El mount is factory configured to achieve elevation angles from 8° to 54°. For higher angles, the elevation adjustment screw setting must be modified. (See table for elevation ranges). Before proceeding with antenna installation, determine the elevation angle for the site (refer to main installation instructions). If the elevation setting for the site is greater than ~ 52°, follow these steps:

Antenna Model	Range As Shipped	Range At High Angle Setting
1.2 m Type 123	8° to 54°	42° to 85°
96 cm Type 960	8° to 54°	34° to 85°

Adjustment procedure:

- 1 Loosen two elevation clamp nuts (in curved slots), and loosen elevation pivot bolts
- 2 Swing the housing up against the underside of the elevation adjustment screw head
- 3 Set the az/el mount on the side closer to the elevation adjustment bolt
- 4 Loosen the bottom nut on the elevation adjustment screw. (Use two open-end wrenches to release the double nuts)
- 5 Run the top nut up tight against the az/el housing and elevation screw head, then back off nut half a turn
- 6 Run bottom nut along the elevation screw against top nut
- 7 While holding the top nut in place with a wrench firmly tighten the bottom nut against it to lock them both in that position.
- 8 The az/el is now configured for high elevation angles. Proceed with the installation as instructed in the installation manual.

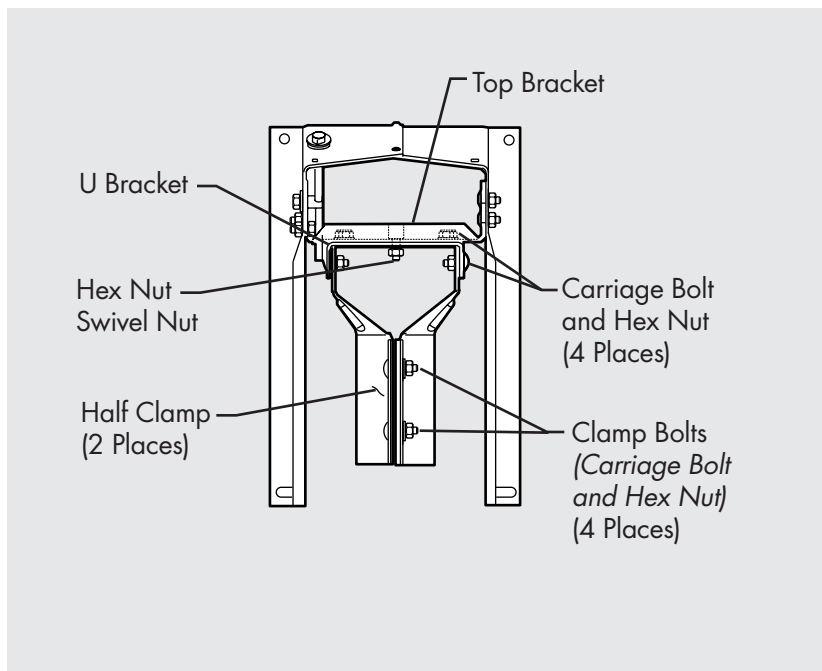
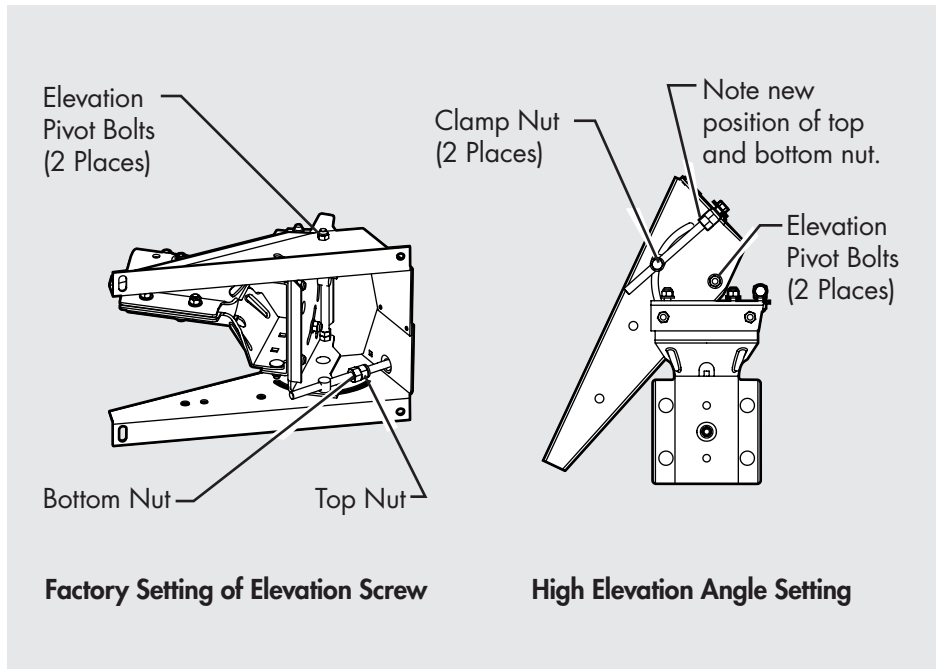

Loosen (4) carriage bolts and nuts securing the "U" bracket to the top bracket. Loosen (4) carriage bolts and nuts securing "U" Bracket to (2) half clamps. Loosen swivel nut and hex nut. Install AZ/EL cap mount onto ground pole. Equally tighten (4) clamp bolts so that cap is held stationary on ground pole, but can be swiveled with slight pressure (approximately 2.7 N-m (2 ft-lb)). Retighten and torque (4) carriage bolts and nuts securing "U" bracket to half clamps to 24.4 Nm (18 ft-lb). Leave loose (4) carriage bolts, swivel nut and hex nuts, for fine tune option.

ASSEMBLY AND INSTALLATION

Installing Az/El Cap Mount Onto Pole

Before installing az/el cap onto pole, installation mount should be in place. Loosen (4) hex nuts on pipe clamp. Install az/el cap onto pole. Equally tighten (4) clamp bolts so that cap is held stationary on pole, but can be swiveled with slight pressure. Tighten approximately 2.7 N-m (2 ft-lb).

Insert (2) M8 set screws into threaded inserts in pipe clamp. Do not tighten.

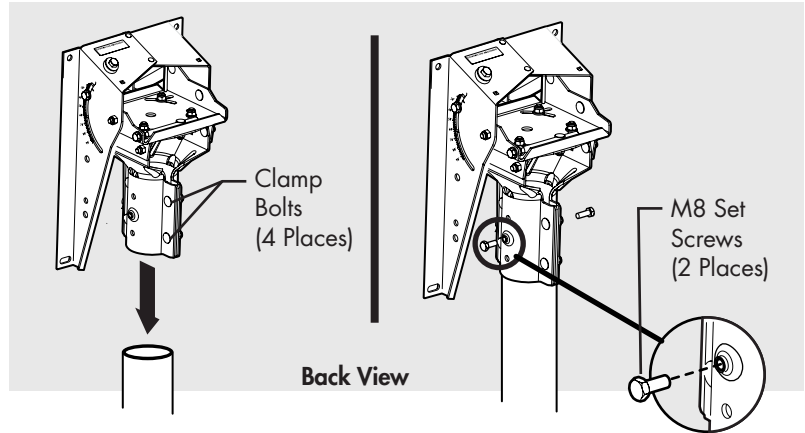

Assembling Reflector Onto Az/El Cap Mount

Install four M8 x 60 mm plow bolts into holes in reflector face. Lift reflector and insert exposed portion of bolt into holes in az/el mounting flange. Secure reflector to az/el mount with 4 lock washers and hex nuts onto plow bolts. Tighten and torque to 15 N-m (11 ft-lb). Press fit hole plugs in remaining four unused holes of the reflector.

IMPORTANT: Note orientation of feed leg mounting holes in reflector rim. Top of reflector does NOT have feed leg mounting hole.

Front View of Reflector

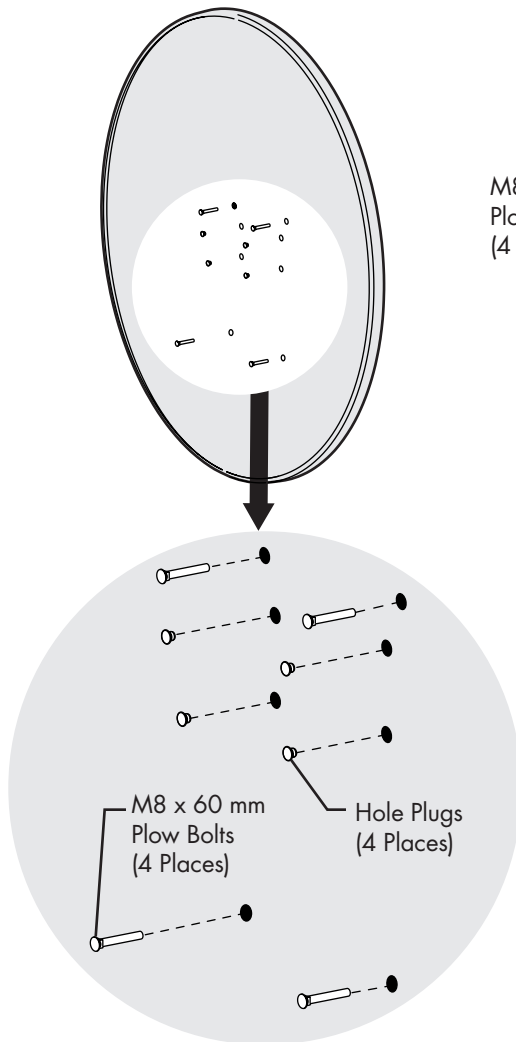

Rear View of Reflector

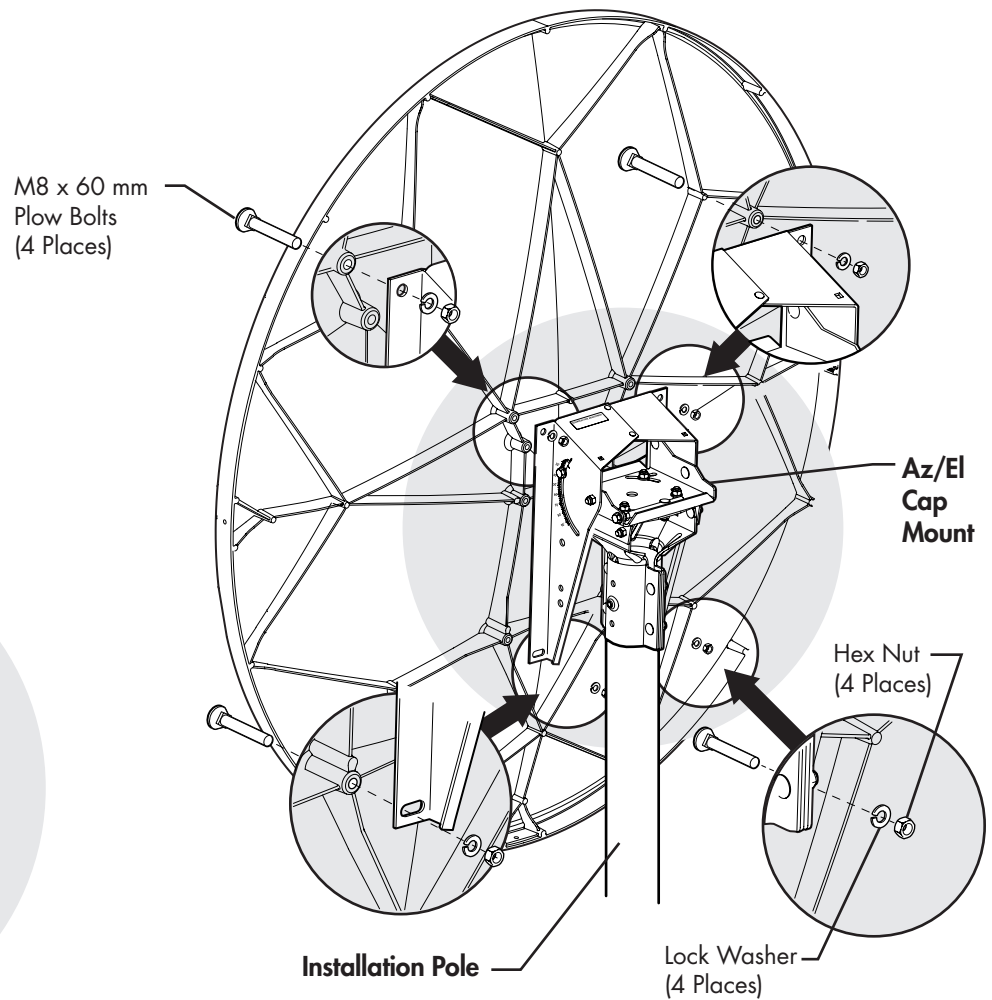

ASSEMBLY AND INSTALLATION for Class I Antennas

Class I Junction Block and Feed Leg Installation

Insert bottom feed leg into junction block and twist until lance engages.

NOTE: Bottom feed leg is the one with a slight bend and a lance on one end. It is shorter than the side feed legs. The end with the lance inserts in junction block and end with bend attaches to reflector.

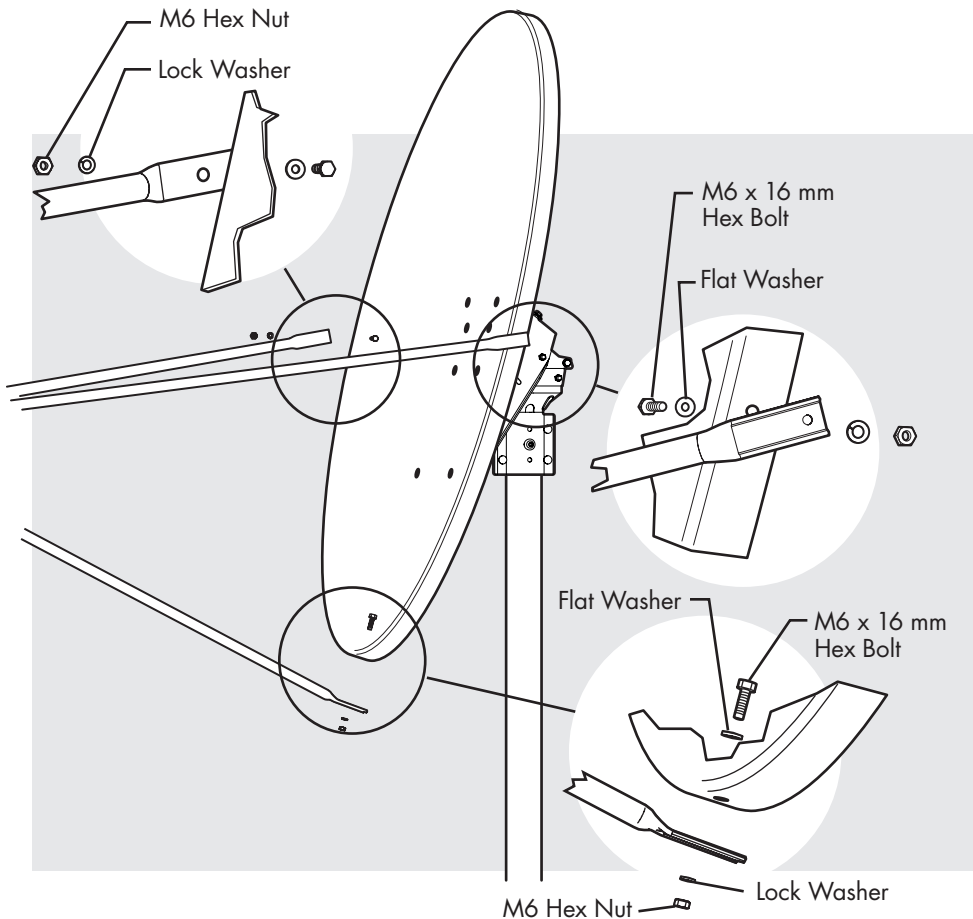
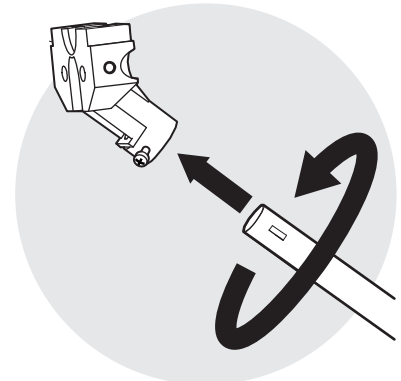

Class I Feed Legs Installation

Assemble side feed legs to side rim of reflector and bottom feed leg to bottom rim of reflector. From the inside of reflector rim, insert M6 x16 mm hex bolt through washer, hole in rim and feed leg hole. Secure with lock washer and hex nut.

Class I Feed Assembly Installation

Attach side feed legs to junction block with M6 x 16 mm Hex Head Bolt and M6 Lock Washer.

NOTE: Long formed end of side feed leg attaches to the reflector rim, short formed end to side of junction block.

Tighten and torque all hardware to junction block and reflector to 5.4 N-m (4 ft-lb). Tighten two M4 pan head screws in junction block socket equally.

Attach feed assembly to junction block with two M6 x 16 mm hex head bolts, two lock washers and mounting block clamp as shown on right. Refer to instructions packed with feed assembly.

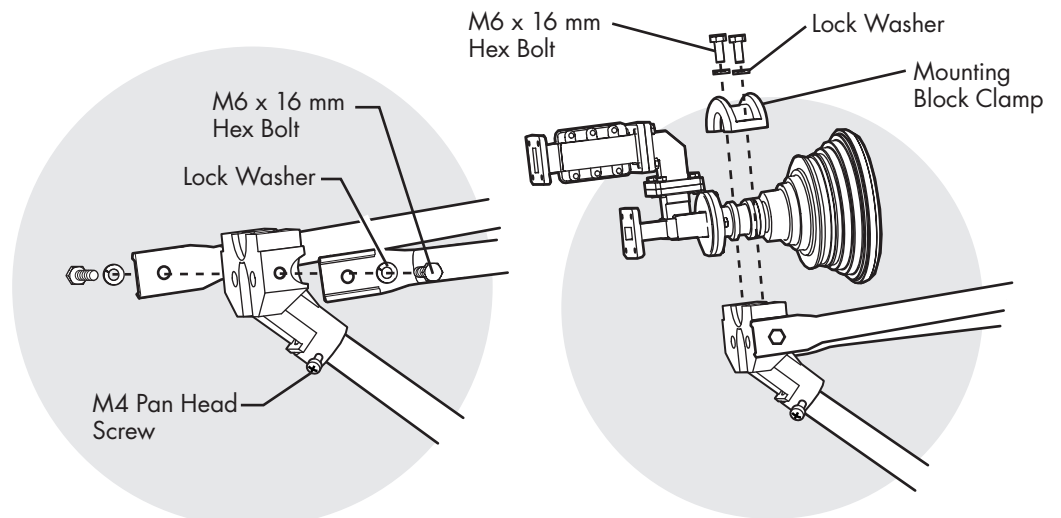

ASSEMBLY AND INSTALLATION for Class II Antennas

Class II Side Feed Legs and Mount Braces Installation

Before attaching side feed legs, locate mount braces and identify left and right parts. Attach one end of each brace (flattened oval end with slotted hole) to the az/el mount housing with carriage bolt, washer, lock washer and hex nut as shown below. Do not tighten. Swing opposite end of mount brace in position to align flange holes with holes in side rim of reflector as shown.

NOTE: Long formed end of side feed leg attaches to the reflector rim, short formed end to side of feed support junction block.

From the inside of reflector rim, insert M6 x 16 mm hex bolt through flat washer and aligned slot of mount brace, reflector rim side hole and hole in feed support leg. Secure side feed legs and mount braces to reflector side rim with lock washer and hex nut. Do not tighten.

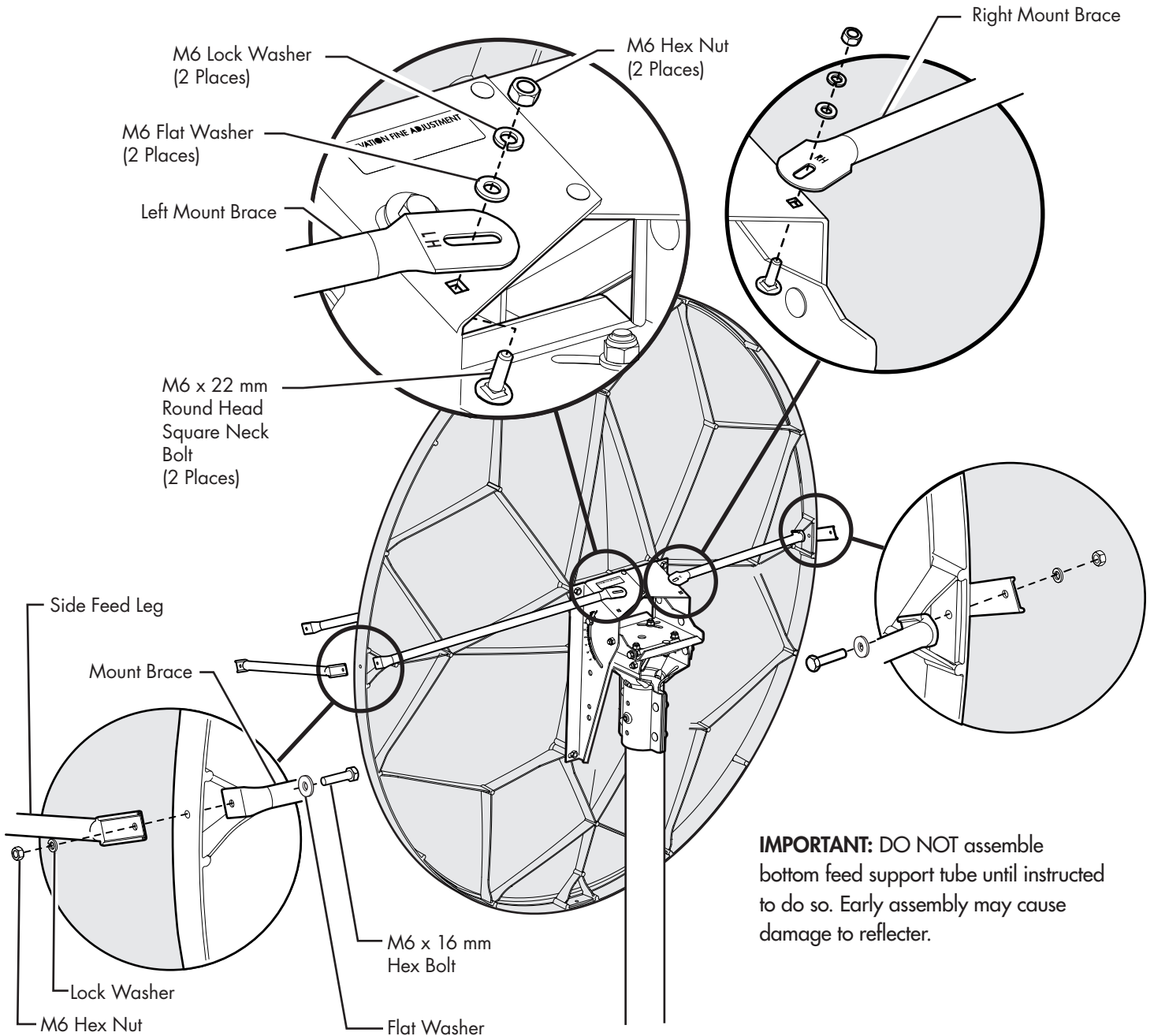

ASSEMBLY AND INSTALLATION for Class II Antennas

Class II Side Feed Legs, Support Block and Feed Assembly Installation

Attach support block to support tube with two M6 x 16 mm hex bolts and two M6 lock washers. Tighten hardware.

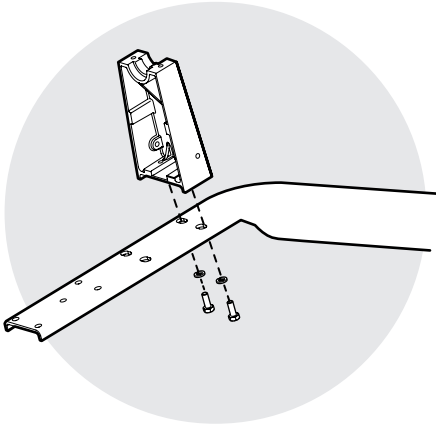

Attach side feed legs to support block with two M6 x 20 mm hex bolts and two M6 lock washers. Do not tighten.

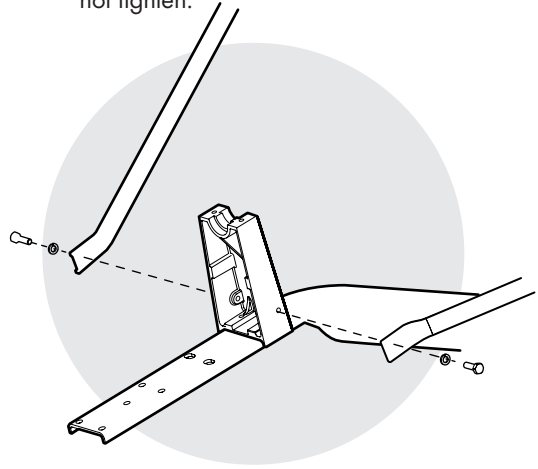

With side feed legs and support block in place, swing support tube as shown and align support tube hole with bottom rim hole of reflector rim. Attach support tube to reflector with M6 x 16 mm hex bolt, flat washer, lock washer and M6 hex nut.

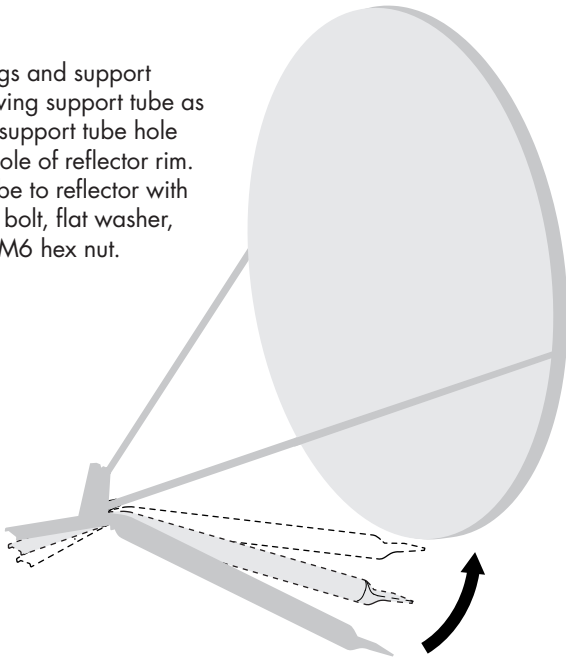

Rear View Detail of Support Tube and Reflector Assembly

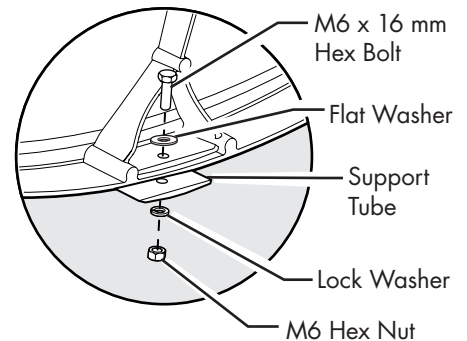

Now tighten feed support and mount brace hardware.

Attach feed assembly to support block with two M6 x 30 mm hex head bolts, two lock washers and a mounting block clamp as shown below.

Refer to instructions packed with feed assembly.

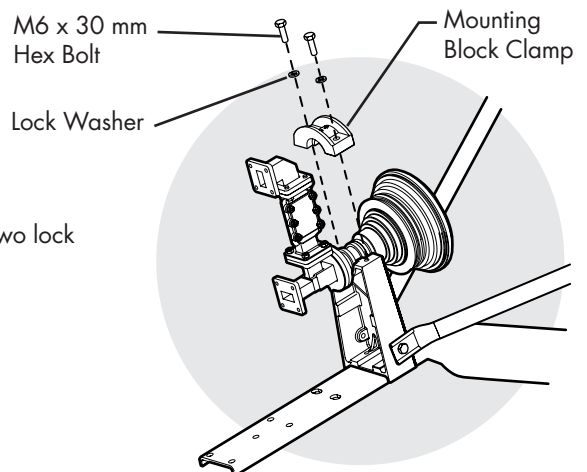

ANTENNA ALIGNMENT PROCEDURE

Satellite Alignment

Alignment with the satellite is obtained by setting polarization, elevation, and azimuth. Charts are provided in this manual to determine the values for your earth station antenna site. "ΔL" is the difference between the earth station antenna site longitude and the satellite longitude. Use "ΔL" and your earth station latitude to obtain polarization, elevation or azimuth setting.

Polarization of Feed

Loosen feed Horn clamp bolts and turn feed clockwise or counterclockwise, depending on being east or west of the satellite as shown on Chart 1. For coarse setting, align marks on the horn scale. Polarization chart assumes antenna system polarization is transmit vertical and satellite vertical Pol is perpendicular to plane of geostationary arc. For horizontal transmit of antenna, feed must be rotated 90° from values shown. (Starting point for polarization adjustment is 0°, as shown. Use a signal strength measuring device for final polarization setting and tighten horn clamp bolts to 5.4 N-m (4 ft-lb).

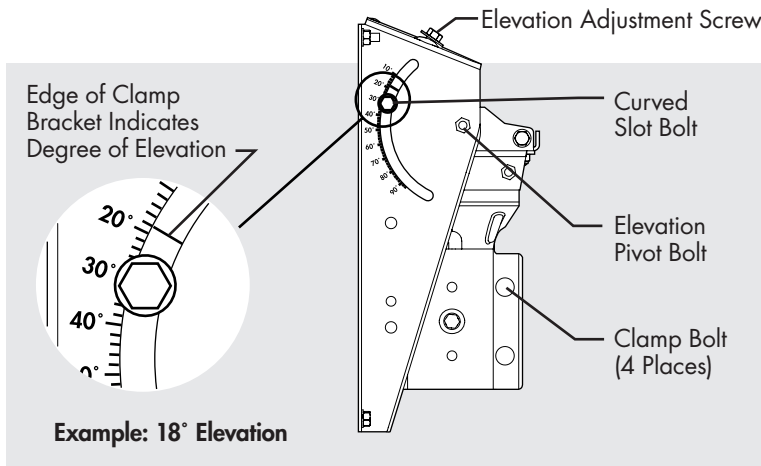
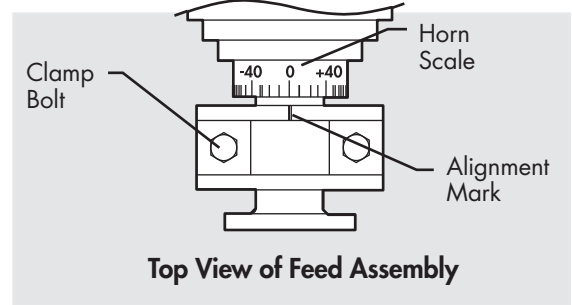

Elevation - Initial Setting

Use Chart 2 and determine your elevation setting. Loosen elevation pivot bolts and bolts in curved slots (both sides) of az/el housing approximately 1 complete turn. Turn elevation adjustment bolt clockwise to decrease elevation and counterclockwise to increase elevation. Align the edge of the clamp with appropriate mark on housing at the desired elevation reading. This will be an approximate setting. Optimum setting achieved when fine tuning.

NOTE: Degree values shown on Elevation Scale are Beam; there is no need to compensate for any offset angle. (See Appendix A, Outline Drawing). If clinometer is used, you must compensate for offset angle.

Azimuth - Initial Setting

Use Chart 3 and determine your azimuth setting. Values in chart must be adjusted for magnetic deviation for your location for correct compass reading. Rotate reflector and mount pointing it to the correct compass reading. Slowly sweep the antenna in azimuth until signal is found. If the desired signal is not found, increase or decrease elevation setting and repeat the azimuth sweep. Tighten half clamp bolts and set screws.

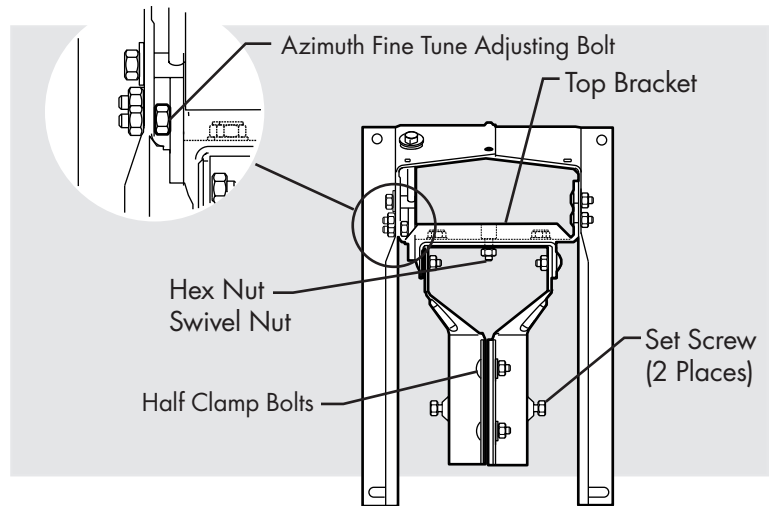
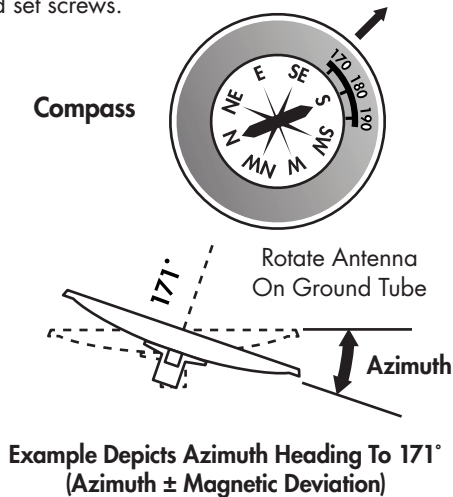

Fine Tuning

Use Signal Tuning Device for final adjustments to obtain maximum antenna performance. Alternate between elevation and azimuth fine tuning to reach maximum signal strength, until no improvement can be detected. Azimuth is fine tuned by loosening the (4) carriage head bolts and swivel nut which allows adjusting the azimuth fine tune adjusting bolt for the peak signal. When fine tuning is complete, tighten and torque all az/el hardware to 16.3 N-m (12 ft-lb). Do not exceed 16.3 N-m (12 ft-lb). Torque Clamp Hardware to 24.4 N-m (18 ft-lb) in alternating sequence.

IMPORTANT: Recheck and repeat torque on four clamp bolts, in alternating sequence, until all bolts are equally torqued to 18 ft-lb.

GROUNDING PROCEDURE

INSTALLATION POLE MOUNT

Note: Grounding wire and hardware are not supplied for pole mount, trimast wall mount or non penetrating roof mount. Installation mount and associated hardware are not supplied.

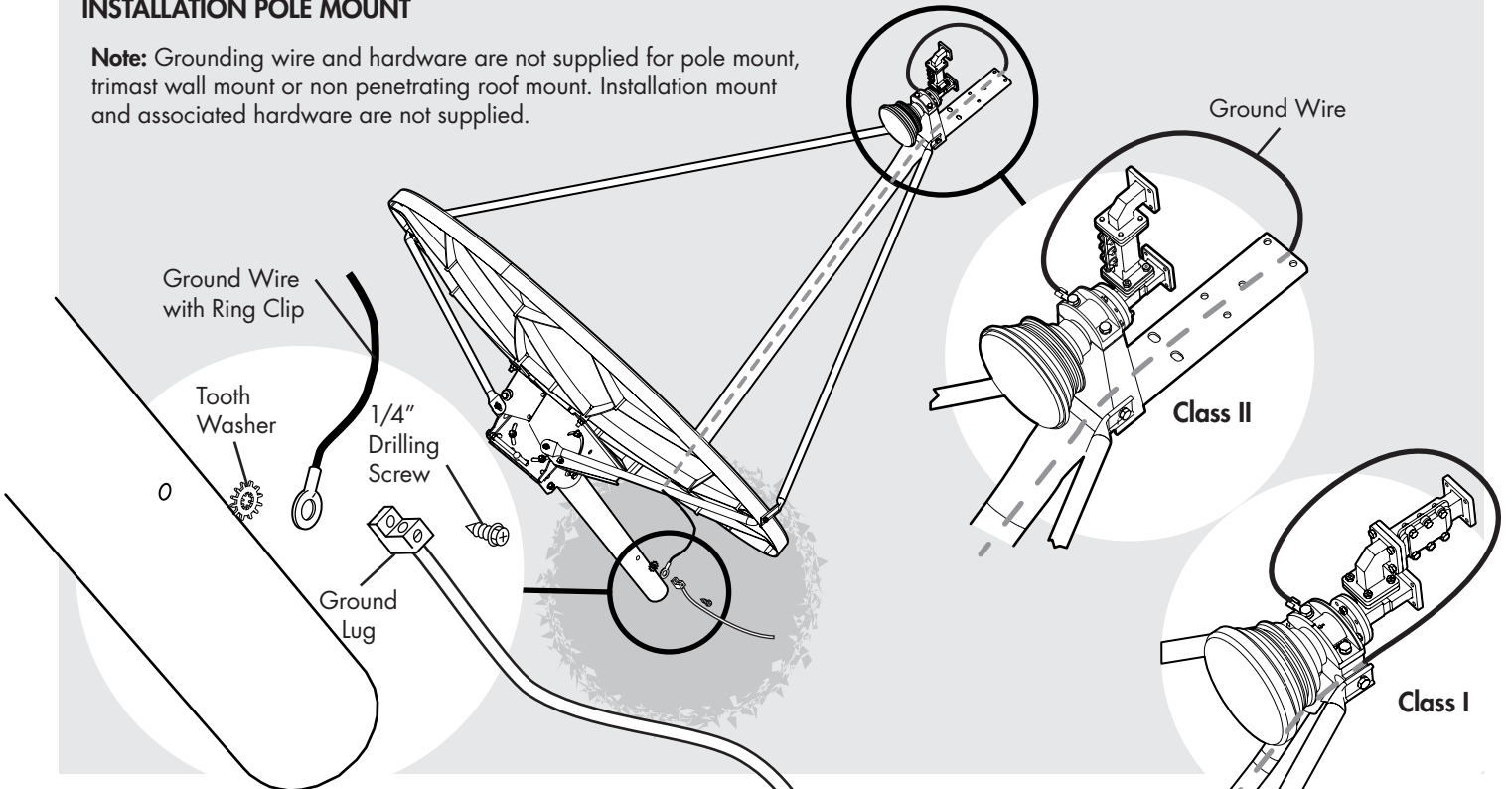

TRIMAST WALL MOUNT

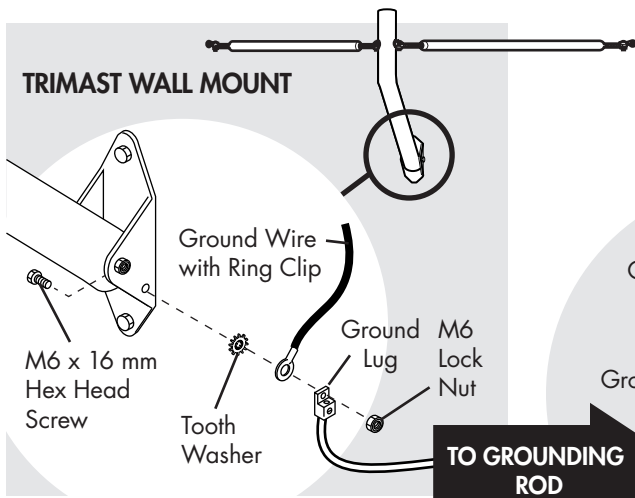

Non Penetrating Roof Mount

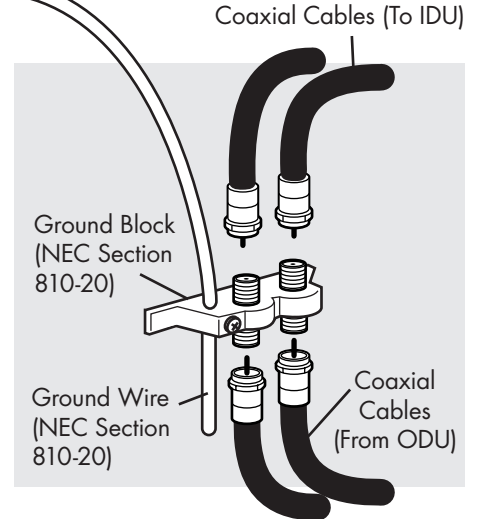
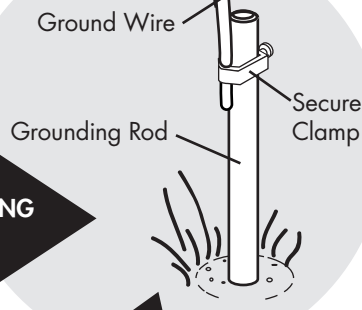
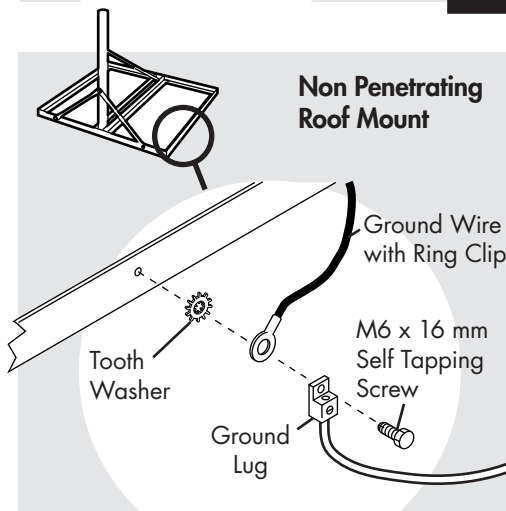

Note: Ground wire, secure clamp, grounding rod, coaxial cables and ground block are not supplied.

IMPORTANT: All antenna systems must be properly grounded. Refer to NEC (National Electric Code) Article 810, 820 and local building codes for specific requirements. Typical grounding methods are shown as examples. Tighten all hardware securely to assure good continuity.

SURVIVAL WIND LOAD CHARTS

96 cm Antenna Survival Wind Loads at 125 mph Velocity

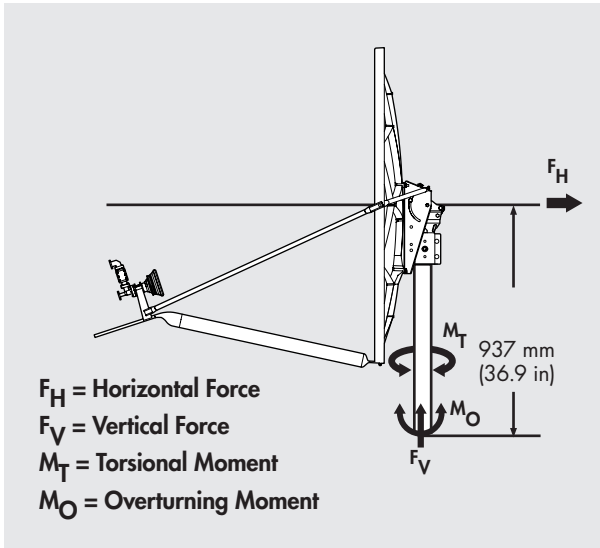

Elevation Degrees		Force N (Pounds)				Moments N-m (Foot-Pounds)			
Mech.	Beam	F_H		F_V		M_T		M_O	
0	15	3,323	(747)	-89	(-20)	203	(150)	3,114	(2,301)
10	25	3,145	(707)	-667	(-150)	199	(147)	2,947	(2,178)
20	35	3,056	(687)	-1,286	(-289)	188	(139)	2,863	(2,116)
30	45	2,767	(622)	-1,837	(-413)	171	(126)	2,592	(1,916)
40	65	2,438	(548)	-2,215	(-498)	145	(107)	2,286	(1,689)
50	75	2,126	(478)	-2,438	(-548)	122	(90)	1,992	(1,472)
60	85	1,770	(398)	-2,549	(-573)	95	(70)	1,660	(1,226)
70	95	1,330	(299)	-1,971	(-443)	73	(54)	1,246	(921)

M_O based on 937 mm (36.9 in) from mounting surface of center line of antenna. Values shown represent maximum forces for any wind direction and include 1.5 F_S . Height and exposure factors from uniform building code are NOT included. Center line based on 36" max. height of mounting post.

1.2 m Antenna Survival Wind Loads at 125 mph Velocity

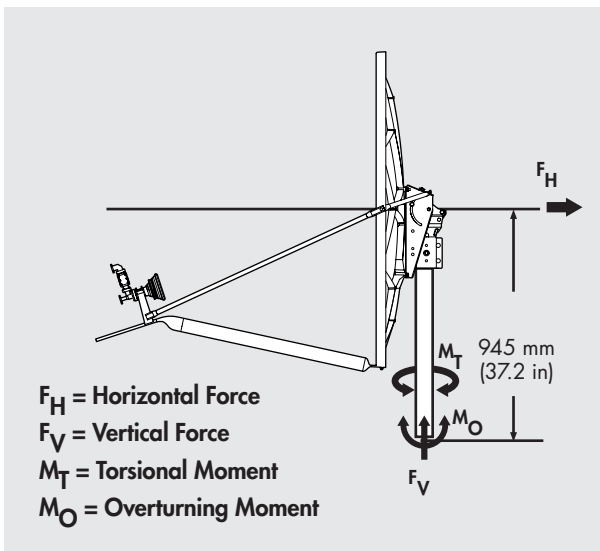

Elevation Degrees		Force N (Pounds)				Moments N-m (Foot-Pounds)			
Mech.	Beam	F_H		F_V		M_T		M_O	
0	17	5,716	(1,285)	-156	(-35)	678	(500)	5401	(3,991)
10	27	5,413	(1,217)	-1,143	(-257)	662	(488)	5115	(3,780)
20	37	5,258	(1,182)	-2,211	(-497)	629	(464)	4969	(3,672)
30	47	4,764	(1,071)	-3,163	(-711)	571	(421)	4501	(3,326)
40	57	4,195	(943)	-3,812	(-857)	484	(357)	3964	(2,929)
50	67	3,656	(822)	-4,195	(-943)	405	(299)	3455	(2,553)
60	77	3,051	(686)	-4,381	(-985)	315	(232)	2883	(2,130)
70	87	2,291	(515)	-3,390	(-762)	241	(178)	2585	(1,910)

M_O based on 945 mm (37.2 in) from mounting surface of center line of antenna. Values shown represent maximum forces for any wind direction and include 1.5 F_S . Height and exposure factors from uniform building code are NOT included. Center line based on 36" max. height of mounting post.

POLARIZATION CHART

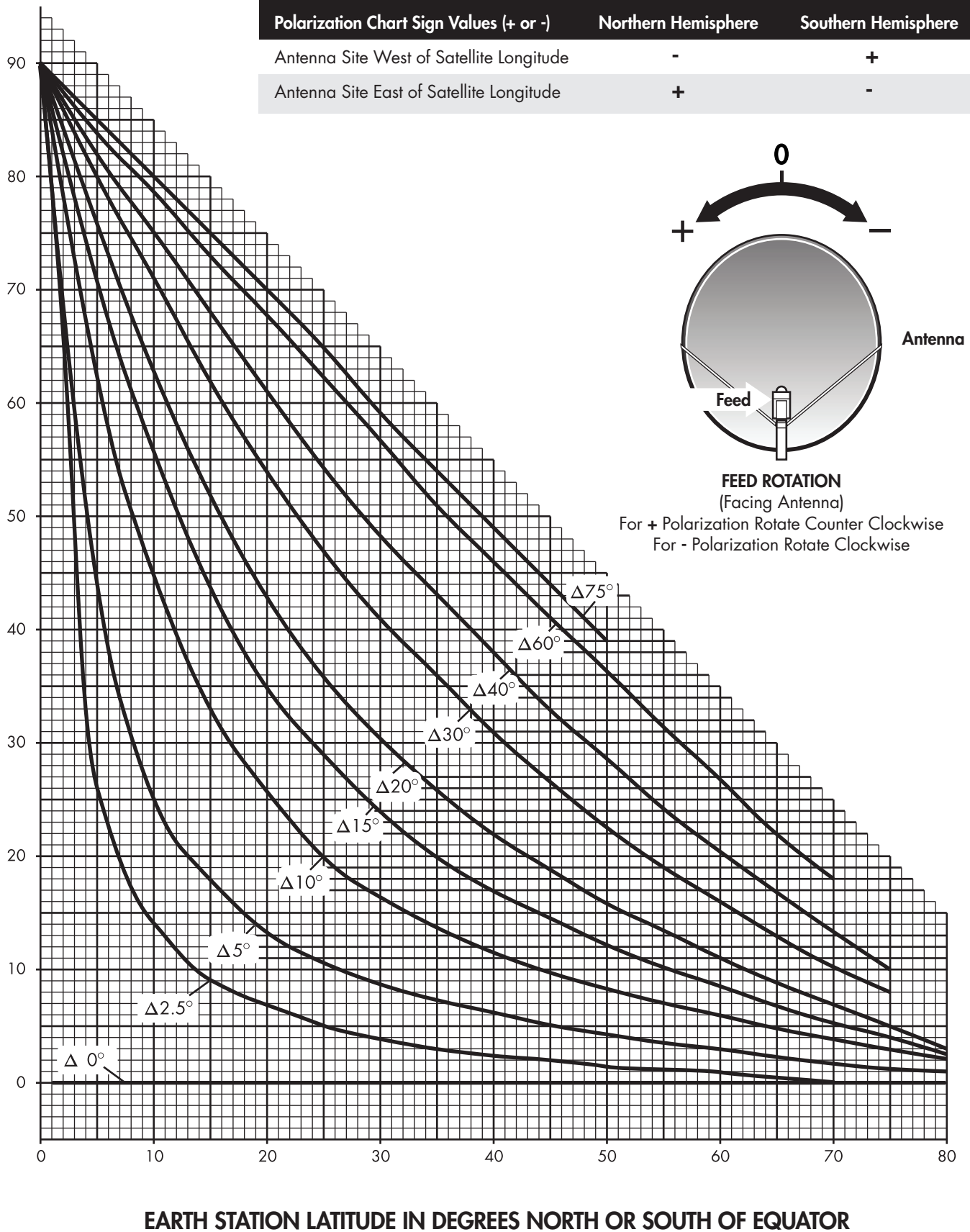

ELEVATION CHART

Use of Elevation Chart

- Determine Δ = the difference between your site longitude and the satellite longitude.
- Find your latitude on horizontal axis.
- Follow your latitude up until you intersect the curve for your Δ .
- Read Elevation value on vertical axis.

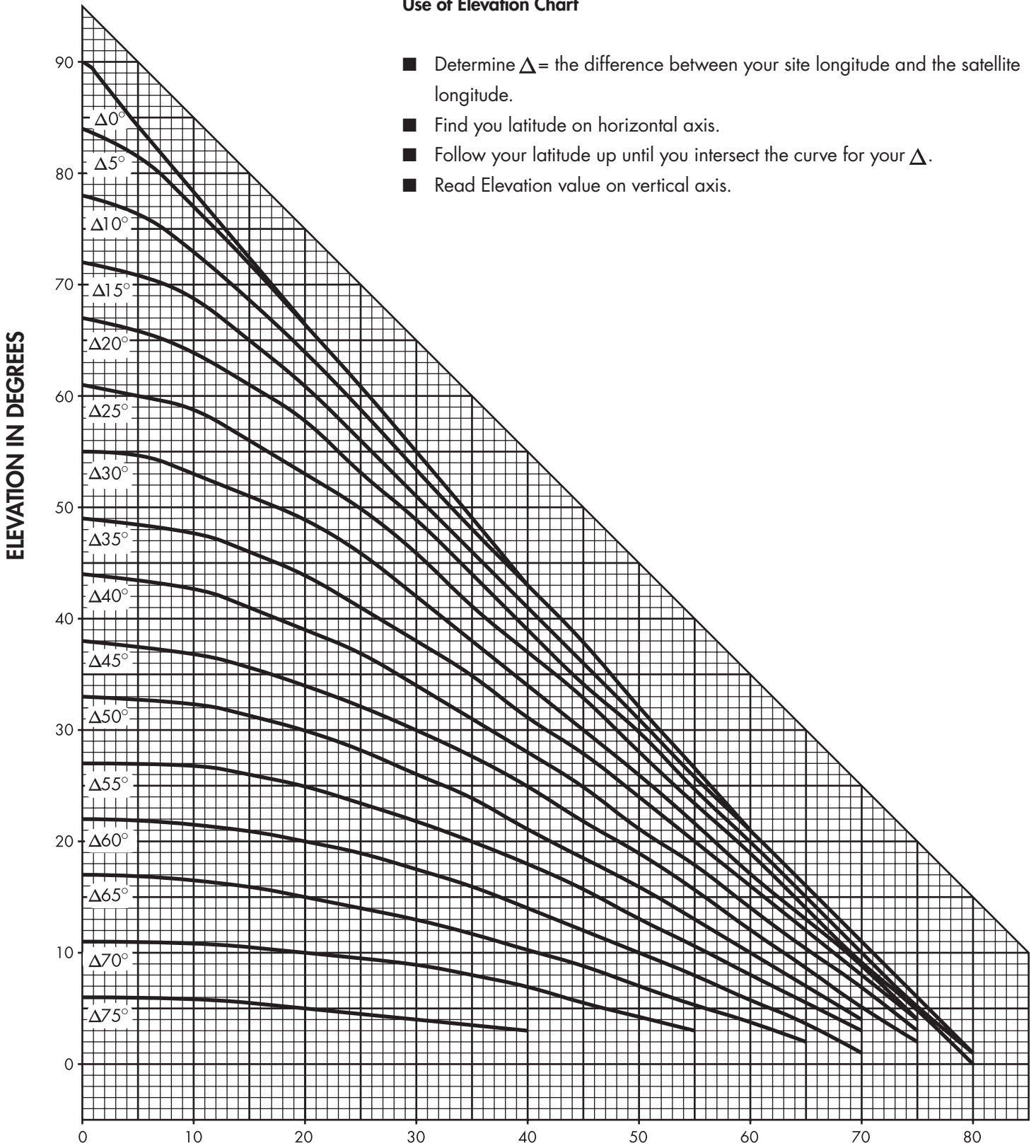

PARTS LIST for CLASS I

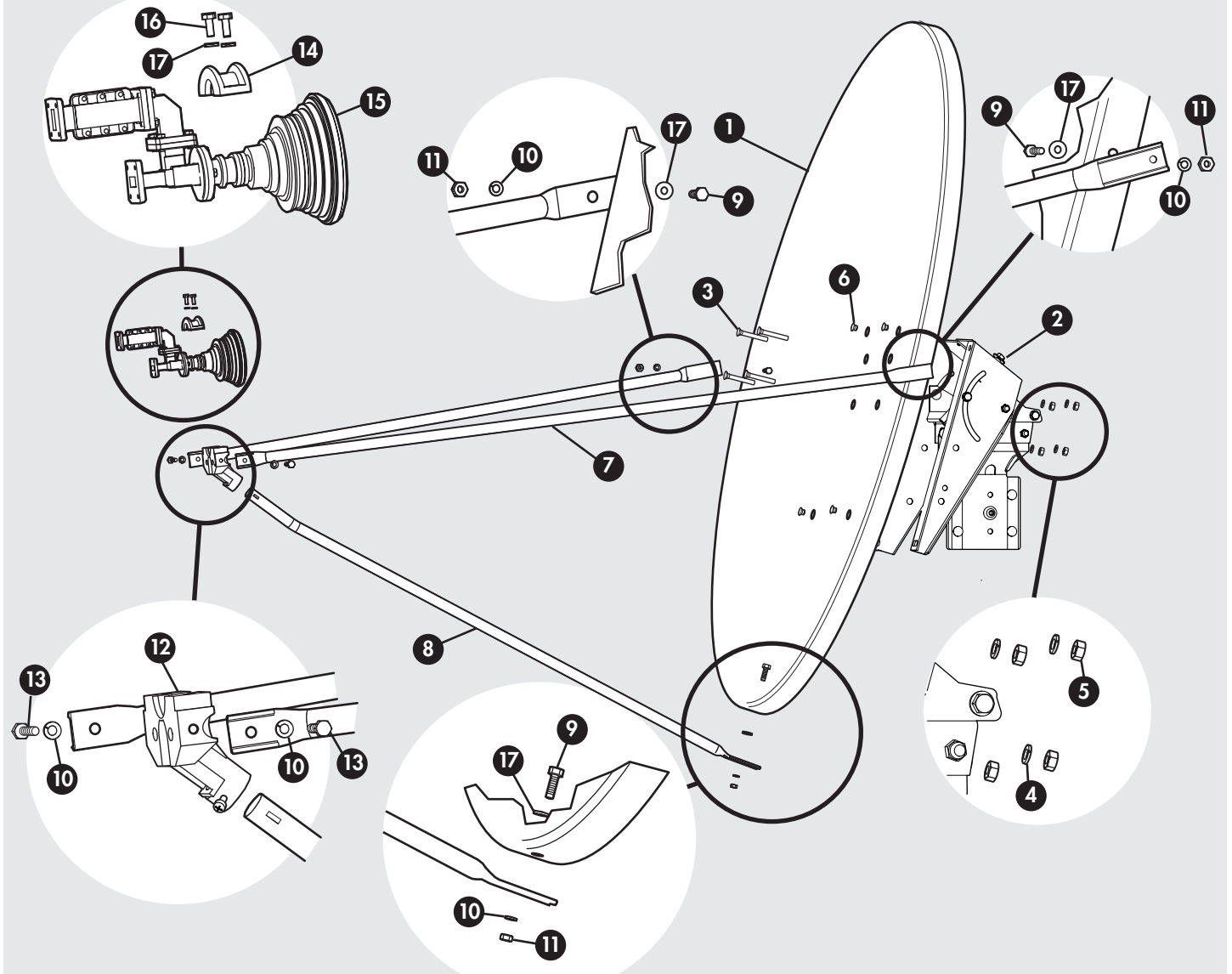

NO.	DESCRIPTION	QTY.
1	96 cm Reflector or 1.2 m Reflector	1
2	Azimuth/Elevation Assembly	1
3	M8 x 60 mm Plow Bolt	4
4	M8 Lock Washer	4
5	M8 Hex Head Nut	4
6	Plug Cap	4
7	96 cm or 1.2 m Side Feed Leg	2
8	96 cm or 1.2 m Bottom Feed Leg	1
9	M6 x 22 Hex Head Bolt	3
10	M6 Lock Washer	5
11	M6 Hex Head Nut	3
12	Junction Block with Pan Head Screws	1
13	M6 x 16 Hex Head Bolt	2
14	Mounting Block Clamp	1
15	Feed Assembly	1
16	M6 x 16 Hex Head Bolt	2
17	M6 Flat Washer	5

PARTS LIST for CLASS II

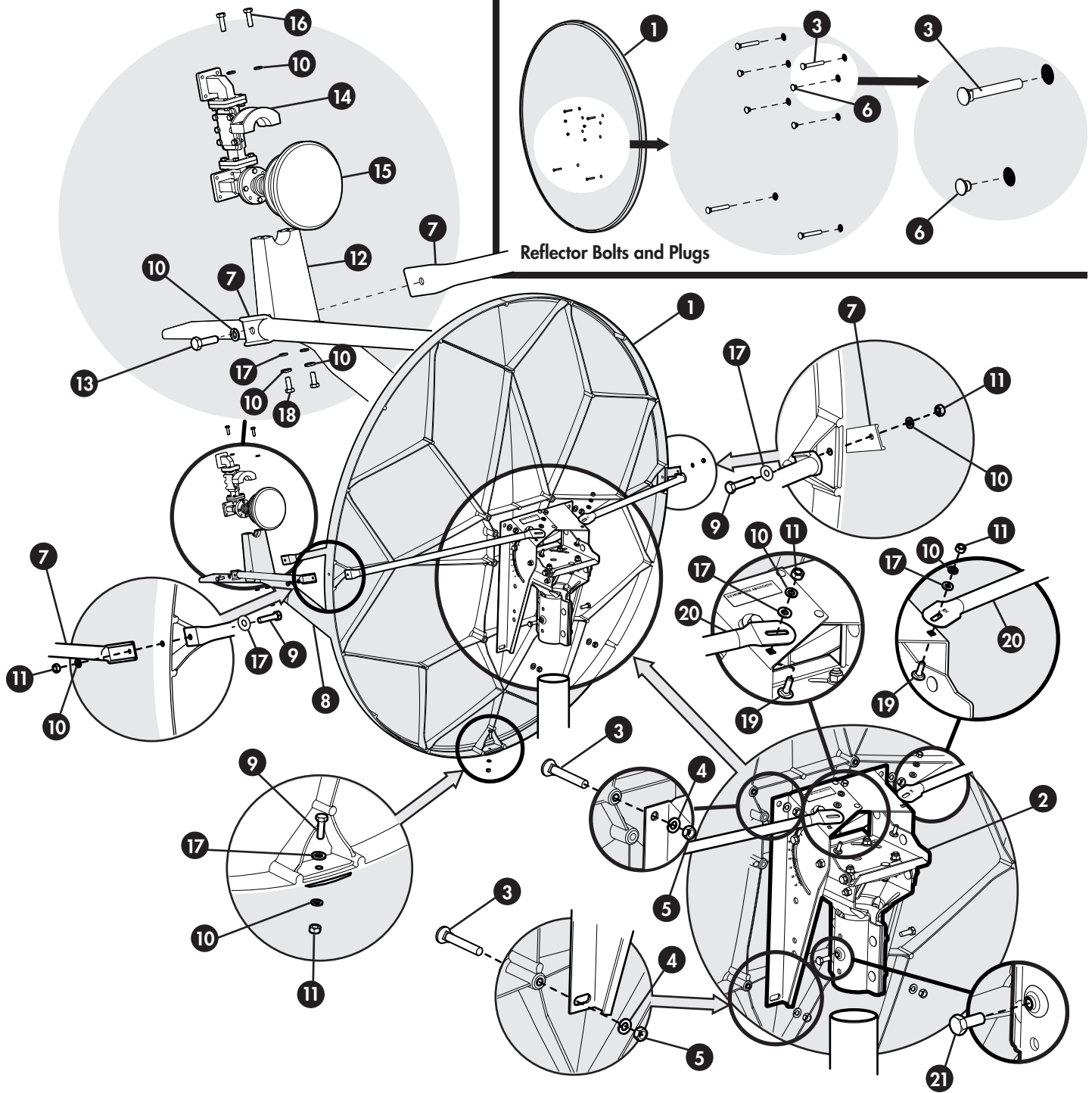

NO.	DESCRIPTION	QTY.
1	96 cm Reflector or 1.2 m Reflector	1
2	Azimuth/Elevation Assembly	1
3	M8 x 60 mm Plow Bolt	4
4	M8 Lock Washer	4
5	M8 Hex Head Nut	4
6	Plug Cap	4
7	96 cm or 1.2 m Side Feed Leg	2
8	96 cm or 1.2 m Bottom Support Tube	1

NO.	DESCRIPTION	QTY.
9	M6 x 22 Hex Head Bolt	3
10	M6 Lock Washer	11
11	M6 Hex Head Nut	5
12	Feed Support Block	1
13	M6 x 20 Hex Head Bolt	2
14	Mounting Block Clamp	1
15	Feed Assembly	1
16	M6 x 30 Hex Head Bolt	2

NO.	DESCRIPTION	QTY.
17	M6 Flat Washer	7
18	M6 x 16 Hex Head Bolt	2
19	M6 x 22 Round Head Square Neck Bolt	2
20	Mount Brace	2
21	M8 x 20 Hex Head Bolt	2