

READY: (+UP -dwn)
IDLE SatA0 99.0

RUN
STOP

TracStar
COBHAM

TracStar Series Antennas

Operating Instructions

September 2008
Version 4.0

TracStar Systems, Inc.
1551 College Park Business Center Road • Orlando, FL • 32804
Ph: 407-650-9054 • Fax: 407-650-9086
www.cobham.com/tracstar

!! CAUTION !!

Antennas are typically shipped fully configured for a network. Changing data in the antenna controller may render the antenna inoperable. Change controller settings with caution.



TracStar Controller Menu Grid

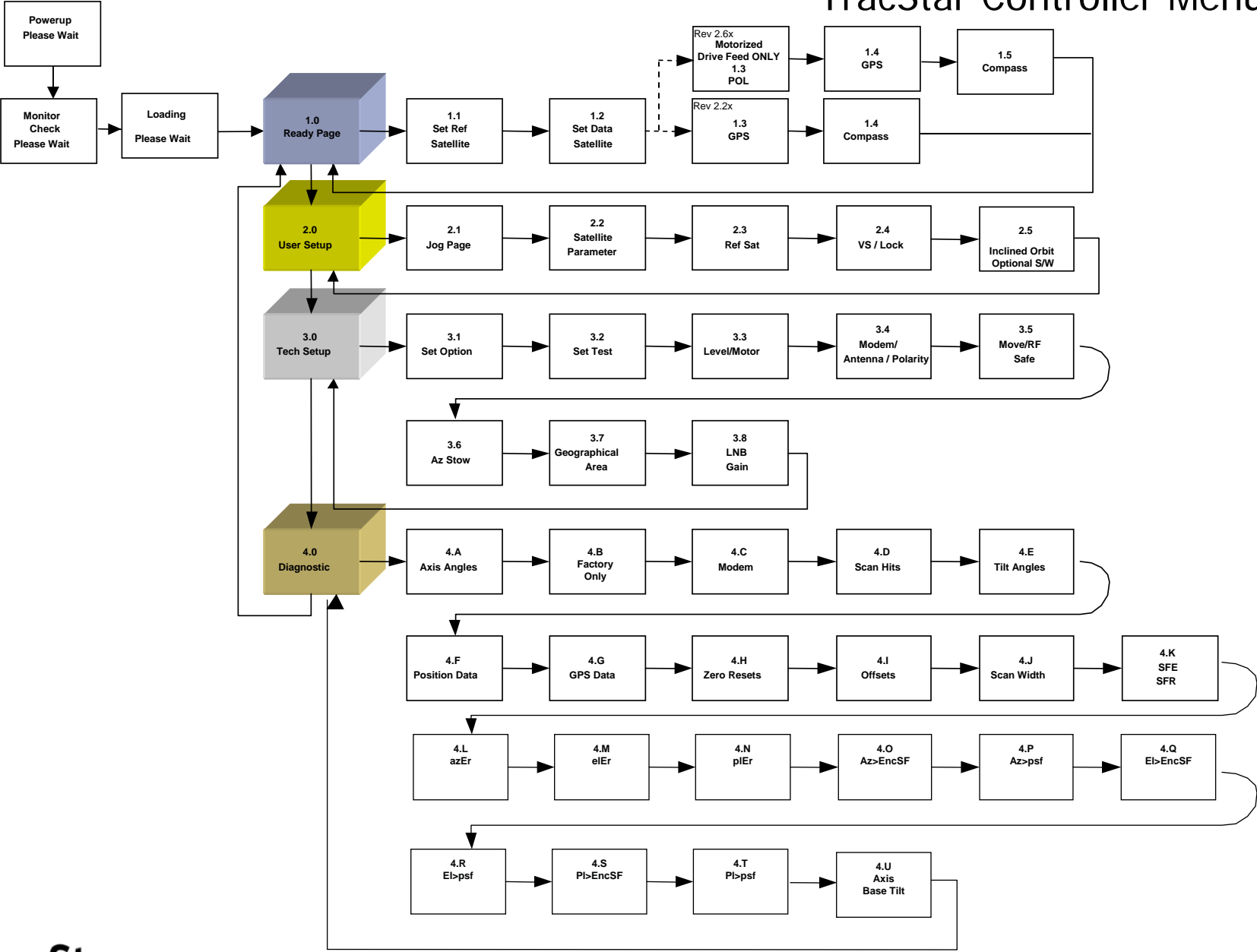

Data Is Subject To Change Without Notice.

This document is supplied as and intended to be a reference document for TracStar Systems product users. The document is periodically updated and may contain data that does not apply to users specific product or that is obsolete. If questions exist regarding the applicability of the data relative to your product, contact TracStar Technical Support.

This manual and its contents are considered proprietary intellectual property of TracStar Systems, Inc. Unauthorized use or distribution is specifically prohibited. Contents are protected by law.

© Copyright 2008, TracStar Systems, Inc. All rights reserved.

TracStar Systems is a registered trademark of Cobham, PLC.

Roto-Lok[®] is a registered trademark of Sagebrush Technologies

Any and all additional product names referred to in this manual may be trademarks or registered trademarks of their respective companies. Such trademarks are the sole property of their respective owners.

QUICK START USERS GUIDE

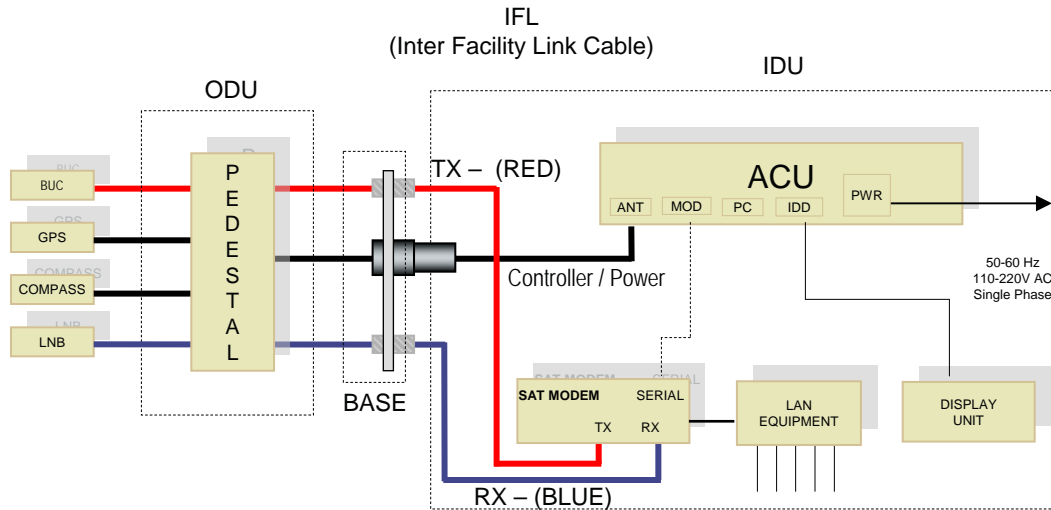

NOTE THE FOLLOWING WARNING

- Do NOT connect or disconnect the RG6 Coaxial cables or antenna controller cable while power is applied to any connected equipment. Turn off all power before connecting or removing cables. Failure to do so may cause damage to the system.

TURN KEY OPERATION

- Deploy
 - Connect antenna as shown above – (the MOD-SERIAL cable is required for modems using GPS input. The cable may be a DB9-DB9 or a DB9-RJ45 w/a RJ45 jumper cable, depending on modem style.)
 - Apply power from the tabletop power supply or the 1U rack mount power supply, which ever applies.
 - Once the control panel interface displays “READY”, press “+” and hold for 2 seconds.
- Stow
 - Press the MAIN button until the display reads “READY”
 - Observe green LED’s on the controller interface panel. If necessary, push “Run” once for “Ready/Idle” to be displayed.
 - Press the “-” button and hold for 2 seconds – allow antenna to fully stow
 - Remove power from the antenna by turning off power to the power supply or the 1U rack mount panel, which ever applies.
 - Once power is removed, disconnect any cables necessary for transporting the antenna.

WHAT TO EXPECT

- The antenna has a self-calibration and startup routine. User intervention is not required after the initiation of this process. Under normal operating conditions the antenna will determine its absolute location, find its predetermined reference satellite, then find and lock onto the desired data satellite. Satellite LOCK can be determined by a message on the display unit showing LOCK XXX.X with XXX.X being the desired satellite.

PERFORMANCE TIPS

- If after a number of unsuccessful scans or several minutes have passed and no “LOCK” indication is present on the display:
 - Turn off power and check cable and power connections to all equipment, being careful to observe all warnings. Ensure the satellite modem is connected properly. Reapply Power.
 - Ensure there is a clear, unobstructed view towards the equator relative to the antenna’s position.
 - Check leveling of antenna. Auto-correction software will accommodate up to $\pm 10^\circ$ of error in the mounting plane of the antenna. Begin the process again.
 - If the controller display shows “LOCK” and Voice is available and Internet access is not available, check IP addressing of your computer and set to “DHCP”.

Using the Antenna

- The TracStar control system is resident on the antenna.
- No data is stored in the controller's ACU (Auxiliary Control Unit).
- Either the IDD with the 'Blue Box' or the 1RU controller interface serve as I/O devices for the user's antenna system.



TracStar
Controller
System



Auxiliary Control Unit
The desktop controller's
IDD and the 1RU
rackmount controller
serve as controller
interface devices to the
antenna based TracStar
control system.



OR

1. Basic Connectivity Information
2. Basic Theory of Operation
3. Antenna Setup Options
4. Antenna Operations and Display Unit Instructions
5. Connection information & diagrams for various modems and configurations



IMPORTANT



ARROW 1X
MAIN 2X

PgUP / PgDn

- Denotes information *TracStar* feels is important for product operation.
- Number of times operator must touch respective keypad position to accomplish the direction(s) being given.
- PgUP / PgDn navigates the *TracStar* Manual by decreasing or increasing the page number respectively.

Table of Contents

TracStar Controller Menu Grid	2	2.0 USER SETUP PAGE	33
Legalese	3	2.1 Jog	34
QUICK START USERS GUIDE	4	2.2 Satellite Parameters	36
Using the Antenna	5	2.3 Reference Satellite	38
Content Information	6	2.4 VS/Lock Methods	41
Table of Contents (cont.)	9	3.0 TECH SETUP PAGE	44
BASIC Theory of Operation	10	3.1 Set Option	46
Theory of Operation	11	3.2 Set Test	47
IFL CABLE CONNECTIONS	12	3.3 Level/Motor Control Page	49
Antenna Setup Options	13	3.4 Select Modem/Antenna/Pol	51
1. Quick Setup Reference – Known Reference Satellites - CONUS	14	3.5 Move/RF_SAFE	53
2. Quick Setup Reference – Known Reference Satellites – NON CONUS	15	3.6 Azimuth Stow/External Switch	55
3. Quick Setup - From A Script	16	3.7 USAdvb	57
4. Quick Setup - SkyScan	17	3.8 LNB GAIN	59
Users Manual DATA Presentation and ACU Operation	18	4.0 DIAGNOSTICS PAGE	61
TracStar ACU Unit Display and Layout	19	4.A Axis Angles	62
1.0 READY PAGE	20	4.B B Page	63
1.0 Typical Acquisition Sequence	21	4.C C Page	64
DirectPoint – Typical Acquisition Process	22	4.D Scan Hits	65
1.1 Set Reference Satellite	23	4.E Tilt Angles	66
1.2 Select Data Satellite	25	4.F Axis Position Transducer Readout	67
1.3 Polarity	27	4.G GPS Data	68
1.4 Manual GPS Input	29	4.H Axis Zero Offsets	69
1.5 Manual Compass Input	31	4.I Axis Offsets	70
		4.J Azimuth Scan Width	72
		4.K SFE SFR	74
		4.L Axis Diagnostics	75
		4.M Axis Diagnostics	76
		4.N Axis Diagnostics	77

Table of Contents (cont.)

4.O Axis Diagnostics	78
4.P Axis Diagnostics	79
4.Q Axis Diagnostics	80
4.R Axis Diagnostics	81
4.S Axis Diagnostics	82
4.T Axis Diagnostics	83
4.U Axis Diagnostics	84
TROUBLESHOOTING	85
ERROR MESSAGES & RECOVERY	86
Pedestal Preventative Maintenance	87
Pedestal	88
Appendix B – Connection Directions	99
External Stow Monitoring – Vehicle Mounting	100
Gilat 360E Connection	101
SkyEdge Connection	102
Connexstar Cisco Bruno (Gilat)	103
EMS Technologies Connection	104
EMS with EdgeAccess Connection	105
iDirect Netmodem II Connection	106
Avaya G350 Switch Connection	107
EMS & TracStar Gateway	108
iDirect NetModem II	109
iDirect 3000 Series Connection	110
Linkstar Connection	111
Vipersat Connection	112
ViaSat Surf Beam Connection	113
System Integration Example	114
TracStar Control Cable	115
Console and Cross Over Cable Schema	116
TracStar Controller Menu Grid	117
Product Certifications	118

Antenna Description

- Three axis, polarization over elevation over azimuth
- Configurable for operation on most satellites
- Designed for simple operation, performs precise antenna to satellite alignment with the push of a button or a switch
- Pedestal Description:
 - High precision motors with optical encoders
 - Very low backlash drive system
- Each antenna is fully integrated with
 - GPS
 - Compass
 - DVB Receiver
 - Base level sensor
 - Antenna Control System with User Interface

The Standard Satellite Acquisition Process

- Upon power up and deployment, the following acquisition sequence takes place:
 - Compass aligns the antenna with south (if in the northern hemisphere, to the north if in the southern hemisphere)
 - Antenna acquires GPS for high precision geographic location information
 - Antenna precisely sets elevation angle and sweeps through a selected reference satellite, monitoring signal characteristics of the reference satellite
 - Antenna peaks on reference satellite until the center of the antenna beam is located as an alignment reference. Antenna then peaks on the satellite of interest and performs a high precision alignment to the satellite
 - Antenna sends GPS to satellite modem (if applicable)
 - Satellite modem initiates contact with network operations center

Antenna Description

- DirectPoint™ technology closely couples with the satellite modem thus enhancing the satellite acquisition accuracy and reducing the startup time. The antenna goes directly to the data satellite and using enhanced communications capability with intelligent modems is able to acquire, lock and peak on the specific satellite without the traditional pre-alignment (reference satellite) stage.



The DirectPoint mode is invoked by setting "10000" as the Lock Method Word in the User Setup Page 2.4 and "iDirect" (or other 2-way communication modems) as the "Modem" in Tech Setup Page 3.4.

DirectPoint Acquisition Description

- Upon power up and deployment, the following acquisition sequence takes place:
 - Compass aligns the antenna with south (if in the northern hemisphere, to the north if in the southern hemisphere)
 - Antenna acquires GPS data for high precision geographic location information
 - Using DirectPoint™ and bypassing the selected reference satellite, the antenna pointing algorithm precisely scans to the selected data satellite
 - Monitoring signal characteristics specific to this data satellite, the antenna peaks on the center of the satellite beam and performs a high precision alignment to this satellite
 - After completion of the peaking sequence GPS data is sent to the modem to enable transmit
 - The modem can then automatically initiate contact with the network operations center and be commissioned into the network

IFL CABLE CONNECTIONS

There are two different types of coaxial connectors on the IFL cables. The cable connecting to the antenna is shown below. The two-piece connection allows for the O-ring seal in the smaller nut to be placed on the F Type connector first. Once the cable is connected, the smaller nut is tightened against the cable end allowing the O-ring to provide a moisture proof seal.

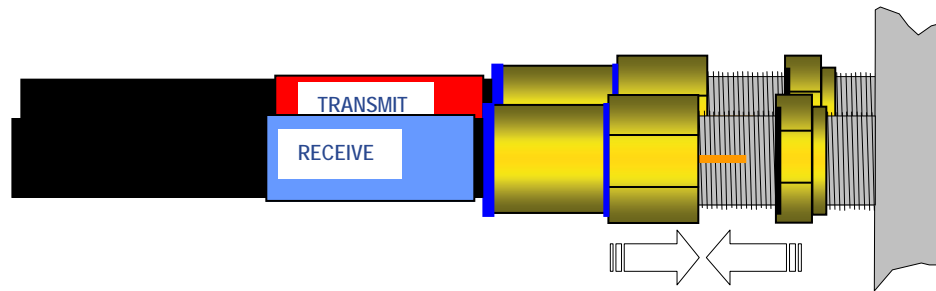

Antenna Setup Options

1. Quick Setup

1. This setup is performed for an antenna system to be used in a geographical region for the first time.
2. The user has known Reference Satellite information.
3. The user does not have Reference Satellite frequencies.

2. Quick Setup Reference from Script

1. This setup is performed for an antenna system to be used in a geographical region for the first time.
2. The user has a script, i.e., orbital positions and frequencies exist for the Reference Satellites and therefore can be entered into the antenna controller.

3. Quick Setup Reference Using SkyScan

1. This setup is performed for an antenna system to be used in a geographical region for the first time.
2. There is no information for Reference Satellites.

4. After the Reference Satellites are input, the following criteria should be considered in selecting them.

1. There can be up to 12 Reference Satellites in the library. A general rule is to select 3-4.
2. The antenna "rated" the satellites during the ScanSky. Reference satellite positions ending with the letter "A" are the most desirable, then "B", then "C". "Z" indicates that sufficient carrier power was not found.
3. Try to select satellites that are low in the orbital ARC (east or west of the users longitude position), i.e., lower on the horizon is better.

1. Quick Setup Reference – Known Reference Satellites - CONUS



IMPORTANT

NOTE:

The factory default setting for Reference Satellite is AUTO. The system will select a reference satellite that is optimum for your GPS position.

Step	Function	Action	Display Page
1.	Power up antenna	Turn on power at ACU	READY
2.	Set Code (enables editing) (Page 3.0)	From READY page Main 2x + to code 13, Enter Main 2x	READY TECH SETUP,[Code 0] Tech Setup [CODE 13] READY
3.	(Input Reference Satellites Page 1.1) Select Ref 61.5 Satellite Select Ref 119.0 Satellite Factory Default is AUTO	From Ready page: Arrow 1x + or – through Ref Sat List ENTER + or – through Ref Sat List Enter Main	READY SetREF, 61.5 XXX.X SetREF, 119.0 XXX.X READY
4.	(Input data satellite parameters Page 1.2) Toggle between SatA and SatB Input orbital position for SatA Input orbital position for SatB	From READY page: Arrow 2x + or – + or – Enter	READY SELECT DATA [SatA] or [SatB] XXX.X

Locate the antenna so that it has an unobstructed view of the orbital arc.

Orient the antenna so that it comes up generally to the south (if located north of equator), north (if located south of equator).

2. Quick Setup Reference – Known Reference Satellites – NON CONUS



IMPORTANT

NOTE:

The factory default setting for Reference Satellite is AUTO. The system will select a reference satellite that is optimum for your GPS position.

Locate the antenna so that it has an unobstructed view of the orbital arc.

Orient the antenna so that it comes up generally to the south (if located north of equator), north (if located south of equator).

*If IDLE SAT shows 0.0, then Satellite Configuration has not been performed and system will err.

Step	Function	Action	Display Page
1.	Power up antenna	Turn on power at ACU	READY
2.	Set Code (enables editing) (Page 3.0)	From READY page Main 2x + to code 13, Enter Main 2x	READY TECH SETUP,[Code 0] Tech Setup [CODE 13] READY
3.	Clear existing satellite data. (Page 3.2)	From READY page Main 2x Arrow 2x + or – to Enter + Enter	READY TECH SETUP [Code 13] SET TEST, [NONE] [CLEAR REF DATA] [CANCEL] [RUN NOW] READY
4.	Input reference satellite parameters. (Page 2.3) Go to reference satellites entry page Leave both default frequencies 10799 Set scan type to Freq Repeat, up to 12 Ref satellites	From READY page Main 1x Arrow 3x Enter + or – to Ref Sat Long ENTER - to [10799] ENTER + TO [Freq] ENTER	READY USER SETUP [Rs 1] [XXX.X] [XXX.X] [XXX.X] [10799] [SS] [Freq]
5.	Run Frequency Scan (Page 3.2 – Set Test/Freq Scan)	From READY page Main 2x Arrow 2x + or – to ENTER + Enter	READY TECH SETUP, [Code 13] SET TEST, [NONE] [SCAN FREQ] [cancel] [RUN NOW] READY
6.	(Input Reference Satellites Page 1.1) Select RefX Satellite Select RefY Satellite	From Ready page: Arrow 1x + or – through Ref Sat List ENTER + or – through Ref Sat List Enter Main	READY SetREF, X XXX.X SetREF, Y XXX.X READY
7.	(Input data satellite parameters Page 1.2) Toggle between SatA and SatB Input orbital position for SatA Input orbital position for SatB	From READY page: Arrow 2x + or – + or – Enter	READY SELECT DATA [SatA] or [SatB] XXX.X

3. Quick Setup - From A Script



IMPORTANT

NOTE:

Locate the antenna so that it has an unobstructed view of the orbital arc.

Orient the antenna so that it comes up generally to the south (if located north of equator), north (if located south of equator).

Step	Function	Action	Display Page
1.	Power up antenna	Turn on power at ACU	READY
2.	Set Code (enables editing) (Page 3.0)	From READY page Main 2x + to code 13, ENTER Main 2x	READY TECH SETUP [Code 0] Tech Setup [CODE 13] READY
3.	Clear existing satellite data. (Page 3.2)	From READY page Main 2x Arrow 2x + or – to ENTER + ENTER	READY TECH SETUP [Code 13] SET TEST, [NONE] [CLEAR REF DATA] [cancel] [RUN NOW] READY
4.	Input reference satellite parameters (Page 2.3) Select Reference Satellite 1 Input orbital position for Ref 1 Input primary frequency for Ref1 Input secondary freq. for Ref1 Repeat, up to 12 Ref satellites	From READY page Main 1x Arrow 3x ENTER + or – then ENTER + or – then ENTER + or – then ENTER + or – then ENTER	READY USER SETUP [Rs 1] [XXX.X] [XXXXX] [XXXXX] [Rs2]
5.	(Input reference satellites Page 1.1) Select RefX satellite Select RefY satellite	From READY page: Arrow 1x + or – then ENTER + or – then ENTER	READY Set Ref XXX.X XXX..X
6.	Input data satellite parameters. (Page 1.2) Toggle between SatA and SatB Input orbital position for SatA Input orbital position for SatB	From READY page Arrow 2x + or – then Enter + or – then Enter + or – then Enter	READY SELECT DATA [SatA] or [SatB] XXX.X XXX.X

4. Quick Setup - SkyScan



IMPORTANT

NOTE:

Locate the antenna so that it has an unobstructed view of the orbital arc.

Orient the antenna so that it comes up generally to the south (if located north of equator), north (if located south of equator).

See Section 3.7 if CLEAR REF DATA is used. Frequency data for LNB must be re-entered.

Step	Function	Action	Display Page
1.	Power up antenna	Turn on power at ACU	READY
2.	Set Code (enables editing) (Page 3.0)	From READY page Main 2x + to code 13, Enter Main 2x	READY TECH SETUP, [Code 0] Tech Setup, [CODE 13]
3.	Clear existing satellite data. (Page 3.2)	From READY page Main 2x Arrow 2x + or - to ENTER + ENTER	READY TECH SETUP, [Code 13] SET TEST, [NONE] [CLEAR REF DATA]* [cancel] [RUN NOW] READY
4.	Initiate ScanSky function:	From SET TEST page + or - to ENTER + ENTER	SET TEST, [NONE] [SCAN Sky] [cancel] [RUN NOW] Initiates Sky Scan
5.	Input reference satellites (Page 1.1) Select RefX satellite Select RefY satellite	From READY page: Arrow 1x + or - then ENTER + or - then ENTER	READY Set Ref XXX.X XXX.X
6.	Input data satellite parameters. (Page 1.2) Toggle between SatA and SatB Input orbital position for SatA Input orbital position for SatB	From READY page Arrow 2x + or - then ENTER + or - then ENTER + or - then ENTER	READY SELECT DATA [SatA] or [SatB] XXX.X XXX.X

Users Manual DATA Presentation and ACU Operation



IMPORTANT

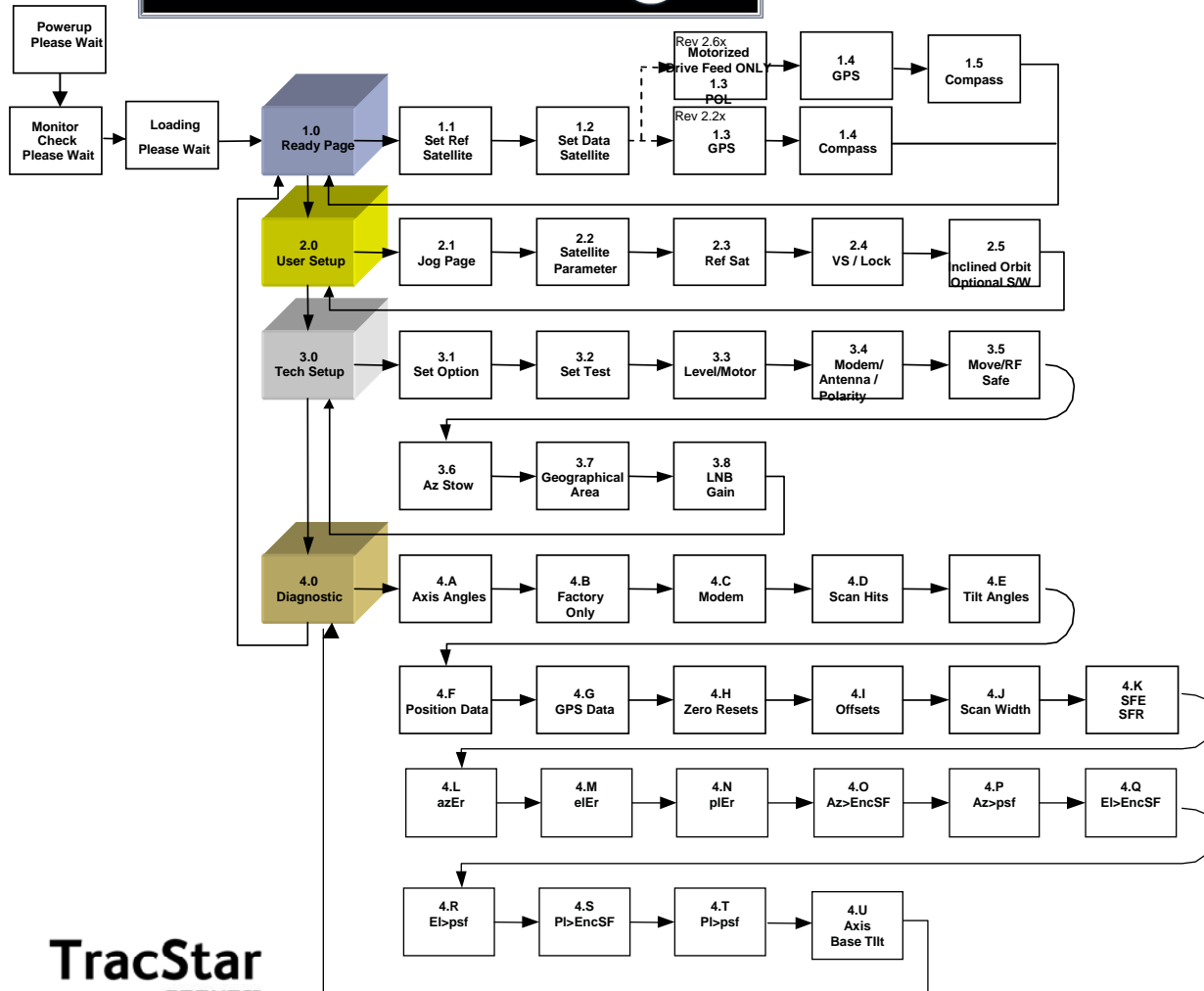

There are four distinct groupings of functions in the operation of the TracStar Auxiliary Control Unit (ACU).

- Ready Page*
- User Setup*
- Tech Setup*
- Diagnostics*

This manual will discuss each of these groups individually.

During actual ACU operation, the various sections are selected by pushing the MAIN button the appropriate number of times thus moving "vertically" to select the desired group function. Hereafter, the block diagram will be shown for each individual function without the other groups functions being represented.

Regardless of what operation is displayed in the ACU display panel, returning to the MAIN or MASTER menu may always be accomplished by continually pressing MAIN until "READY:" appears.

TracStar Controller Display and Layout

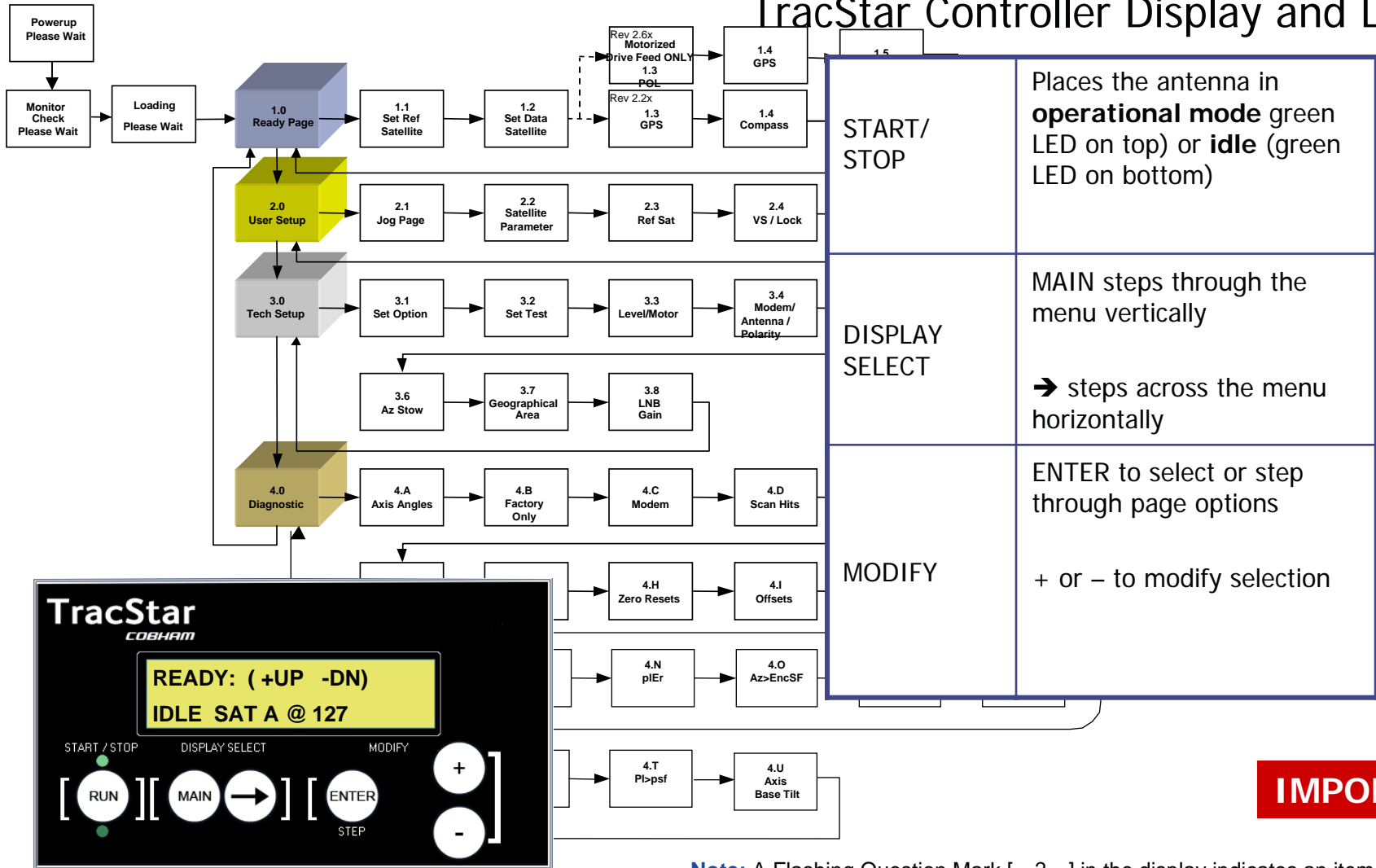

Note: A Flashing Question Mark [---?---] in the display indicates an item has not yet changed in the process. Select the desired item with [+/-] then press enter.



Flashing Blocks indicate something has changed but not been stored in the EPROM. ENTER must still be pressed to move to the next item.

1.0 READY PAGE

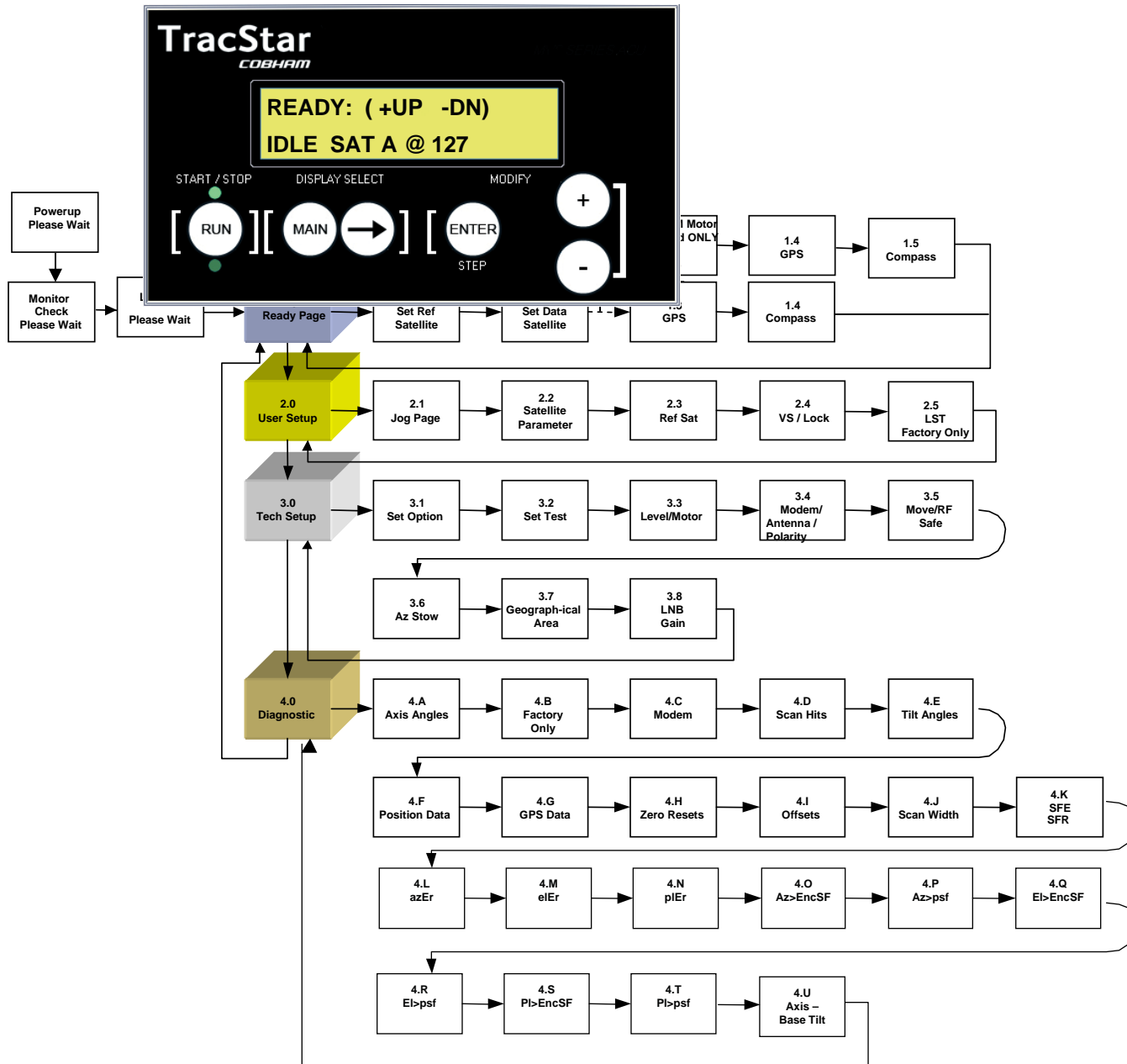

- READY is the main or default page and appears once the system is powered up. The selected satellite and orbital position in degrees longitude is displayed. Positive degrees indicates west longitude, "-" or negative degrees indicates east longitude.
- To activate the system:
- Turn on power to the TracStar Power Supply.
- To deploy: When the display shows "READY", press "+" and hold for 2 seconds to initiate a satellite acquisition. This can be done with the antenna in any position.
- Press the MAIN and \rightarrow keys to navigate through the menu options and the ENTER key to select menu items/options.
- To stow: When the display shows "READY", press "-" and hold for 2 seconds to stow. This can be done with the antenna in any position. Lower LED should be on.
- From the READY page the user can:
 - Press \rightarrow move to the Select Satellite page.
 - Press **MAIN** move to User Setup.
- Note that when the system is in READY (standby) mode the bottom green LED is on. When the system is active the top LED is on.

1. Typical Acquisition Sequence

Message Displayed	Description
POWER UP PLEASE WAIT	Power is being applied to the system
MONITOR CHECK PLEASE WAIT	The system is initiating its internal monitor software
LOADING PLEASE WAIT	The system is going through a momentary warm-up stage (3-5 seconds)
READY: (+ up – down)	The system is in standby mode waiting for instructions (green LED is on bottom): (a) Press + to initiate an acquisition (b) Press – to stow the antenna
RUN: (+/- stop) Startup @ XX	The system is active and has started an acquisition (green LED on top). NOTE: any time the system is active press + or – to place the system in standby.
RUN: (+/- stop) Compass XXX	The system is reading the compass and aligning. Shows relative compass sensor reading.
RUN: (+/- stop) Wait GPS 118	The system is acquiring GPS signals Last digit shows number of GPS satellites acquired.
RUN: (+/- stop) SCAN XXX YYYYY	The system is scanning a reference satellite XXX is orbital position; YYY shows signal strength
RUN: (+/- stop) PEAK XXX YYY	The system is scanning the selected communications satellite
RUN: (+/- stop) Locked XXX YYY	The antenna is locked on the selected satellite
IDLE	To place the system in standby, press + or -, READY page will appear

DirectPoint – Typical Acquisition Process

NOTE:

A reference satellite is not used with the DirectPoint acquisition process. To engage the DirectPoint mode, the modem must be capable of two-way communication with the TracStar controller and a console cable must be connected between the modem and the controller and the controller LOCK Word must be set to 10000*. DirectPoint is typically preset at the factory if shipped with a DirectPoint capable modem. For field setting, follow LOCK Word setup procedures on page 39.

**or appropriate setting as defined in Section 2.4*

Message Displayed	Description
POWER UP PLEASE WAIT	Power is being applied to the system
MONITOR CHECK PLEASE WAIT	The system is initiating its internal monitor software
LOADING PLEASE WAIT	The system is going through a momentary warm-up stage (3-5 seconds)
READY: (+ up – down) Idle Sat A @ xxx	The system is in standby mode waiting for instructions (green LED is on bottom): (a) Press + to initiate an acquisition (b) Press – to stow the antenna
RUN: (+/- stop) Startup @ XXX	The system is active and has started an acquisition (green LED on top). NOTE: any time the system is active press + or – to place the system in standby.
RUN: (+/- stop) Compass XXX	The system is reading the compass and aligning. Shows relative compass sensor reading.
RUN: (+/- stop) Wait GPS 118	The system is acquiring GPS signals Last digit shows number of GPS satellites acquired, +100 if locked
RUN: (+/- stop) SCAN XXX YYYY	The system is scanning the data satellite XXX is the orbital position; YYY = tuner reading; YYYY = analog reading
RUN: (+/- stop) PEAK XXX YYY	The system is scanning the selected communications satellite PEAK XXX shows satellite coordinate PEAKS shows S/N Ratio & Signal Strength
RUN: (+/- stop) Locked XXX YYY	The antenna is locked on the selected satellite. Display loops - Locked @ XXX * PEAKS S/N * GPS Sent * Tx Enabled
	To place the system in standby, press + or -, READY page will appear

SetREF

Xd AUTO Yd 110.0

START / STOP

DISPLAY SELECT

MODIFY



STEP



SetREF

Xd AUTO Yd 110.0Yd

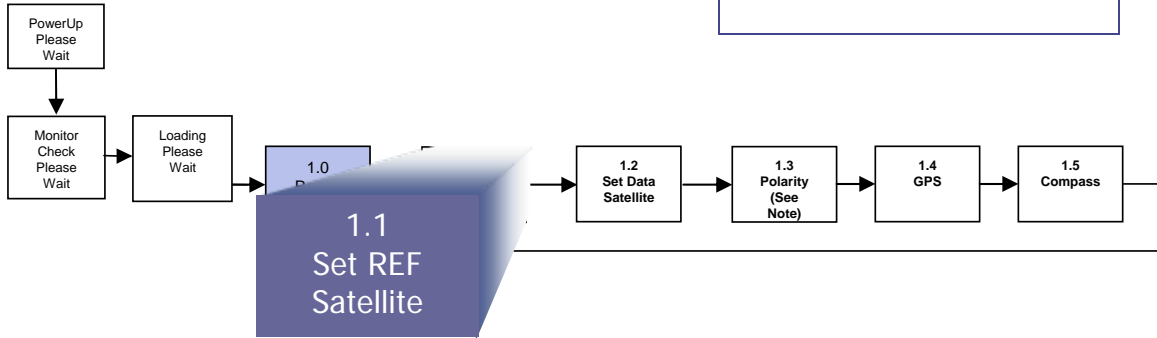

1.1 Set Reference Satellite

- The antenna system uses a reference satellite as part of the acquisition process.
- The Set Reference Satellite page allows the user to select up to two pre-programmed reference satellites from a stored library.
- The RefX is the primary and the RefY is the secondary. The secondary reference satellite will be used in case the primary satellite cannot be found, for example, signal blockage.



IMPORTANT

- **NOTE:** Satellites located west of 0° longitude are positive and those east of 0° are shown as a negative number.
- 1.3 Polarity is only viewable for the 1.2 and 1.8 Meter antennas.
- For best results, the REF satellite should be low to the horizon and not overhead.

1.1 Set Reference Satellite (con't)

Description	Action	Display
Set Code (enables editing) (Page 3.0)	From READY page Main 2x + to code 13 Enter Main 2x	READY TECH SETUP Tech Setup CODE 13
Set Reference Page (Page 1.1)	From Ready Page: Arrow 1x	SetREF X[XXX.X] Y XXX.X
Reference X is the primary reference satellite. Select the appropriate reference satellite from the library. Factory default is AUTO for USAdvb only .	+ or – then Enter (Press + to select known satellite or "auto", then Enter)	SetREF [XXX.X] Y [XXX.X]
Reference Y is the secondary satellite in case the primary satellite is not available, i.e., blockage. In some cases the RefY satellite will be used as a check during the acquisition. <i>If RefX is set as AUTO, then setting RefY to other than AUTO will cause the RefY location to be tried FIRST, followed by the AUTO list as needed.</i>	+ or – then Enter (Press + to select known satellite or "auto", then Enter)	SetREF XXX.X Y [XXX.X]

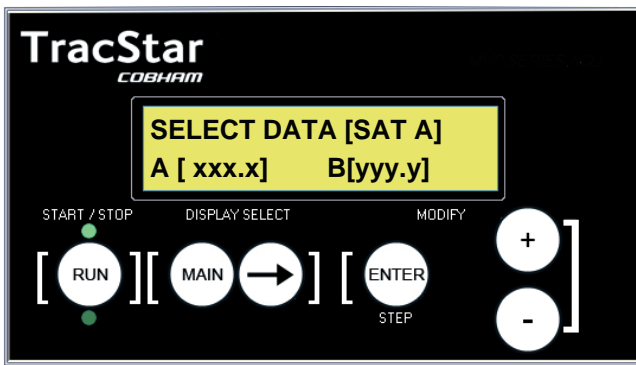

1.2 Select Data Satellite

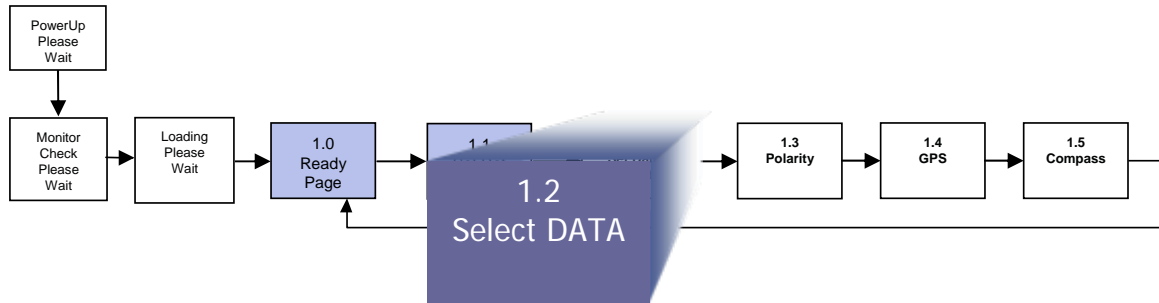
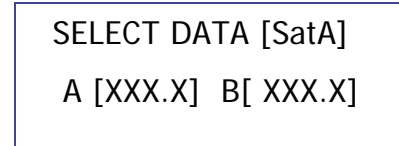

- The Set Data Satellite page allows the user to select the communications satellite of interest.
- The user can select up to two pre-programmed data satellites, SatA and SatB.
- The user can program the desired satellite by entering the orbital position in degrees longitude.



IMPORTANT

- NOTE: Satellites west of 0° longitude must be entered as positive values, satellites east of 0° longitude must be entered as negative values.

1.2 Select Data Satellite (con't)

Description	Action	Display
Set Code (enables editing) (Page 3.0)	From READY page Main 2x + to code 13, Enter Main 2x	READY TECH SETUP Tech Setup CODE 13
Set Satellite Page (Page 1.2)	From Ready Page: Arrow 2x	SELECT DATA [SatA] A XXX.X B XXX.X
When SatA is flashing, the antenna will acquire SatA. The orbital position for SatA is shown on the bottom row as well as on the READY page. Press ENTER to select SatA, or press + to change to SatB , then press ENTER.	+ or – to [SAT A] or [SAT B] ENTER	SELECT DATA [SatA] A XXX.X B XXX.X SELECT DATA [SAT A] [A XXX.X] B XXX.X
Now the orbital position for SatA is flashing and the user can input the desired orbital position in degrees longitude. Press + or - until the desired value is reached then ENTER.	+ or – to Data Sat Long ENTER	SELECT DATA [SatA] A XXX.X B XXX.X SELECT DATA SAT A A XXX.X [B XXX.X]
Now the orbital position for SatB is flashing and the user can input the desired orbital position in degrees longitude. Press + or - until the desired value is reached then ENTER.	+ or – then Enter Main	SELECT DATA SatA A XXX.X [B XXX.X] READY
NOTE: Satellites west of 0° longitude must be entered as positive values, satellites east of 0° longitude must be entered as negative values.		

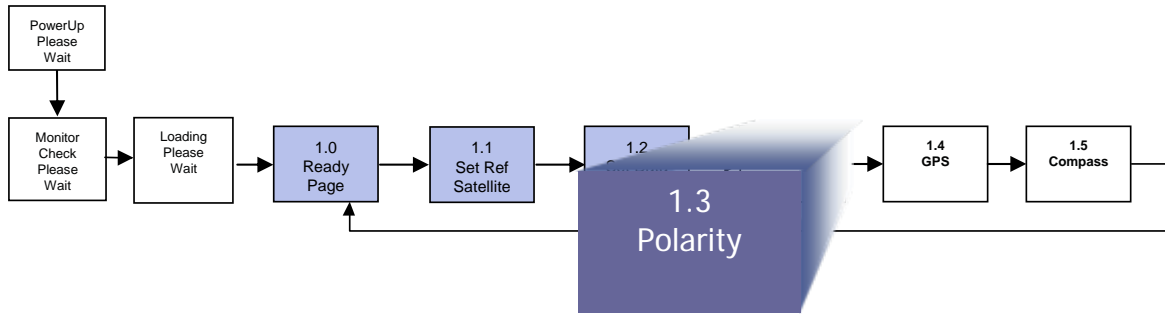
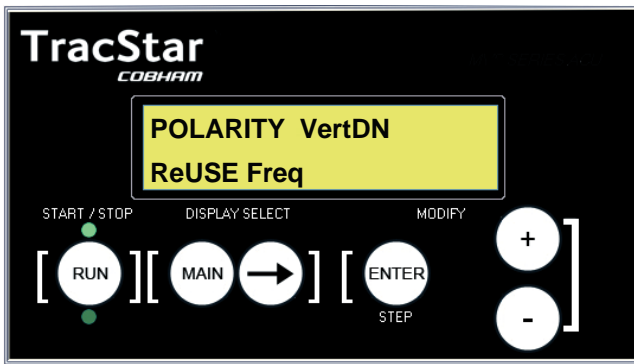

- **Applies to Rev 2.6x or greater SW only (*motorized feed assembly ONLY.*) Is not viewable with other antennas.**
- The user is allowed to change the polarization of the receive frequency
- Allows the user to ReSCAN the existing selection of Satellite A / Satellite B frequency after changing the receive polarity

Description	Action	Display
Polarity Page (Page 1.3) FOR TracStar1200 and 1800 ANTENNAS ONLY	From Ready Page: Arrow 3x	POLARITY [VertDN]
After the code is entered, the word VertDN is flashing. The user can now manually input the desired polarity, VertDN or HorzDN.	+ or – then Enter	POLARITY [VertDN]
ReUSE Freq is now flashing. The user can now manually select the ReUSE or ReSCAN options. <i>NOTE: ReSCAN is not intended to replace the Satellite Parameters / Section 2.2 of the manual. If the proper frequencies are in place for SatA and SatB, a simple ReSCAN can be used after changing polarity. If problems are encountered, refer to Section 2.2, reset the SatA and SatB frequencies to 10799 and the antenna will scan for the best available frequency.</i>	+ or – then Enter 	[ReUSE Freq] [ReSCAN Freq]

IMPORTANT

1.4 Manual GPS Input

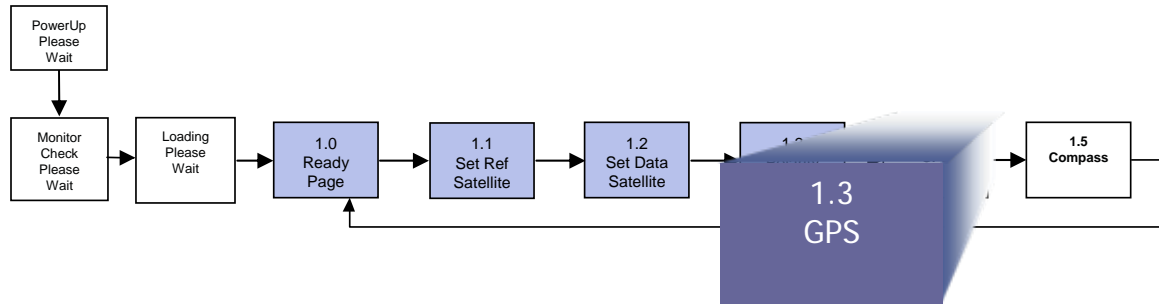
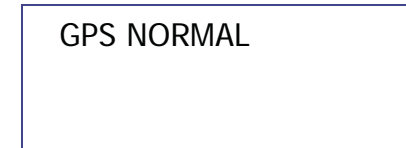
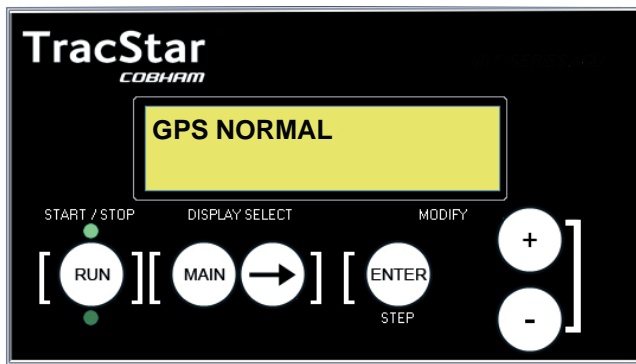

- The antenna system has an integrated GPS to aid in satellite acquisition. The Manual GPS page allows the user to select between the built in GPS (default) or manually input GPS coordinates in case the GPS is unavailable. Power cycling the unit resets to default conditions.

1.4 Manual GPS Input (con't)

Description	Action	Display
Set Code (enables editing) (Page 3.0)	From READY page Main 2x + to code 13, Enter Main 2x	READY TECH SETUP Tech Setup CODE 13
GPS Normal Page (Page 1.4)	From Ready Page: Arrow 4x	GPS [NORMAL]
After the code is entered, the word NORMAL is flashing. The user can now manually input the GPS coordinates.	+ or – then Enter	GPS [NORMAL]
MAN is now flashing, press ENTER to step to the latitude input.	Enter	Gps[MAN] LATXXX.XX LONG XXX.XX
LAT is now flashing, press + or – until the desired coordinate is reached, then press ENTER.	+ or – then Enter	GpsMAN [LAT 22.86] LONG XXX.XX
LONG is now flashing, press + or – until the desired coordinate is reached, then press ENTER.	+ or – then Enter	GpsMAN LAT 22.86 LONG [81.23]



IMPORTANT

NOTES:

1. Coordinates are entered in degrees and decimals of degrees (vs. minutes and seconds)
2. Coordinates west of 0° longitude are positive, east of 0° are negative values.
3. Coordinates north of the equator (latitude) are positive, south of the equator are negative.

1.5 Manual Compass Input

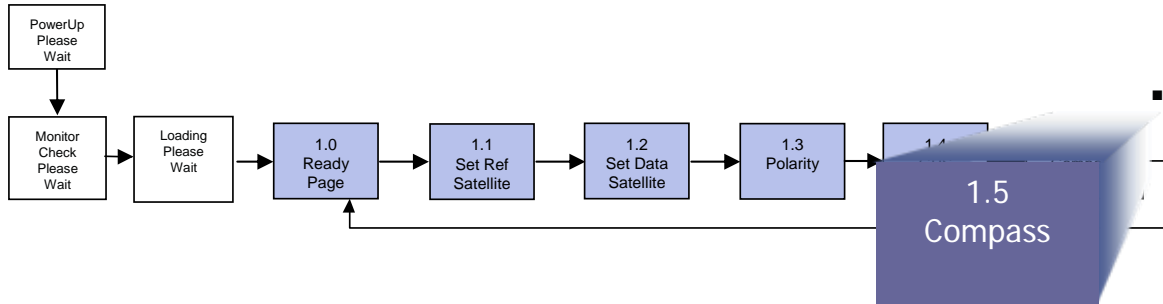
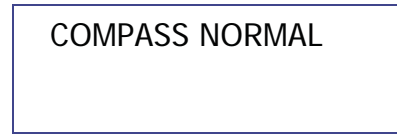
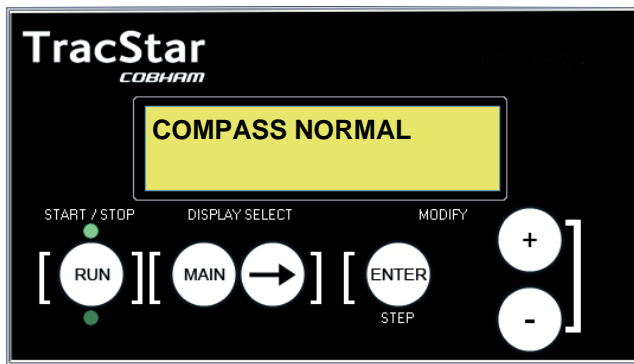

- The antenna system has an integrated compass to aid in satellite acquisition. The Manual Compass page allows the user to provide the antenna with a north or south heading in case the compass is unavailable or heavily influenced by external magnetic fields.
- The Compass Heading selection allows a forced compass heading to be entered where 180 = south.
- The Menu returns to the READY PAGE.
- NOTE: In normal operation, the antenna uses GPS readings and input from modems capable of 2-way communication with the antenna to establish a compass-less heading reference.

1.5 Manual Compass Input (con't)

Description	Action	Display
Set Code (enables editing) (Page 3.0)	From READY page Main 2x + to code 13 Enter Main 2x	READY TECH SETUP Tech Setup CODE 13
COMPASS Page (Page 1.5)	From Ready Page: Arrow 5x	COMPASS [NORMAL]
After the code is entered, the word NORMAL is flashing. Press + or – to change to Manual input, then ENTER.	+ or – then Enter	COMPASS [NORMAL]
The Display now prompts the user to jog the antenna to face or point south (north in southern hemisphere). The Jog function is described in section 2.1.	+ or – then Enter	COMPASS [MANUAL] JOG South, Start
Once the antenna is pointed south using the Jog function, press START and the system will initiate its scan from the manually input south position. * Ideally, the antenna should be pointed as close to south as manual positioning allows.		
The Display now prompts the user to ENTER A KNOWN HEADING. 180 DEGREES = SOUTH	+ or – then Enter	COMPASS [HEADING] JOG Heading, Start

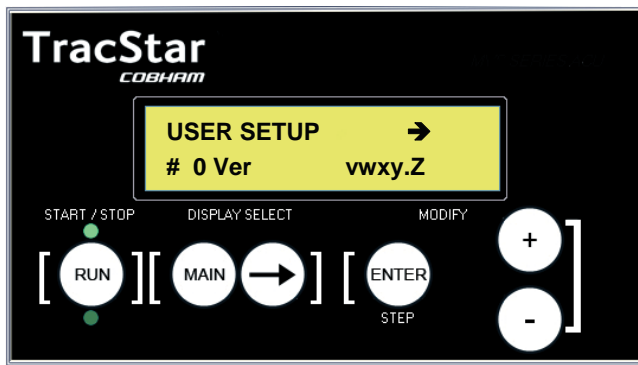

2.0 USER SETUP PAGE

USER SETUP == >
#XXXXX Ver 1.234Z

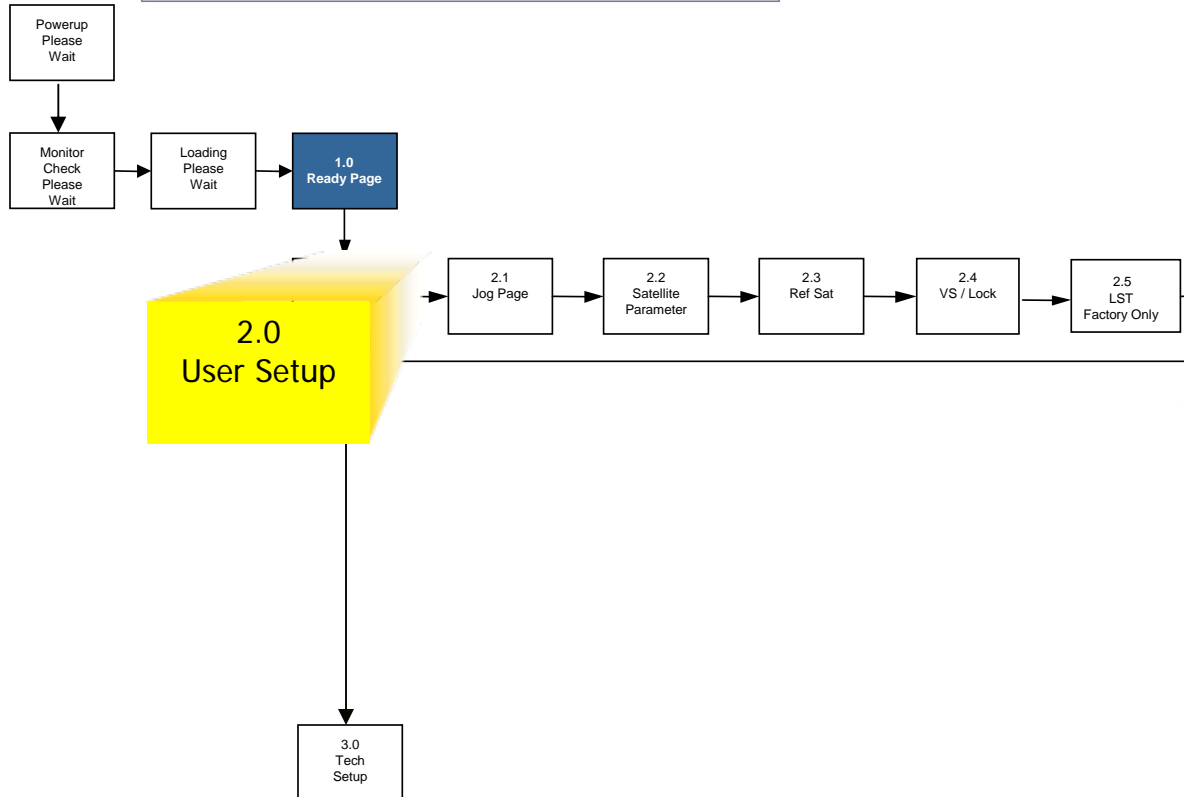

- USER SETUP contains several interactive and setup pages including antenna jog control and satellite parameter setup.
- The antenna serial number and the software version are shown on the bottom row.
- Press  to step to the Jog page or MAIN to step to the TECH SETUP page.

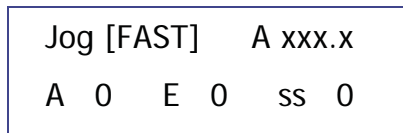
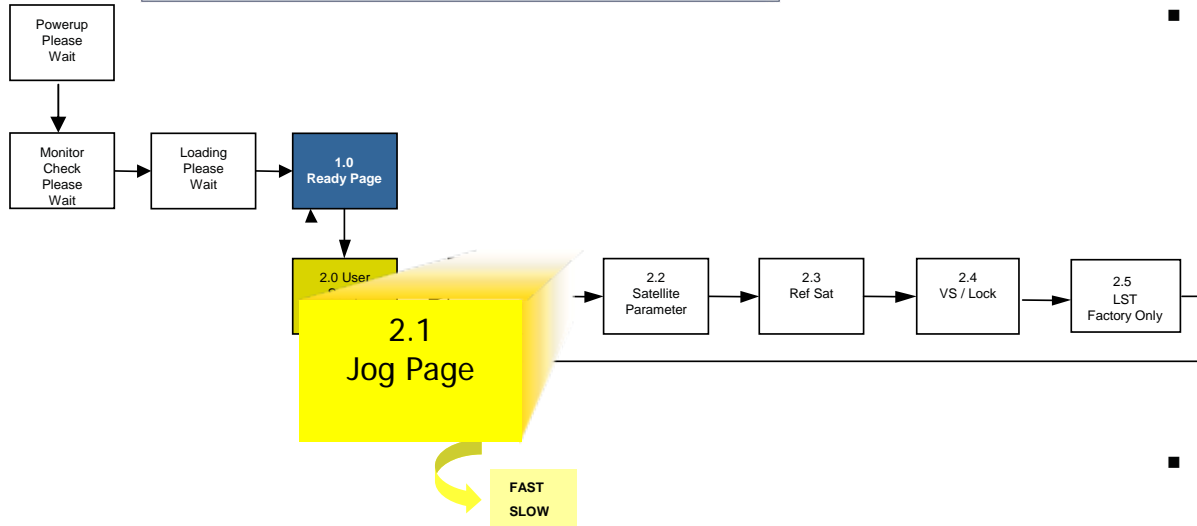
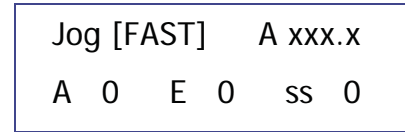
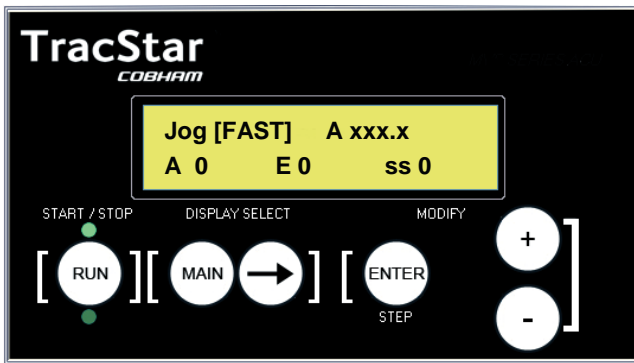

Top A – Denotes position of each respective axis by heading – Az, El, Pol
Based on selected axis below. Top A changes to E for Elevation and P for Polarity.

Bottom A, E, P (ss alternately) - # of button pushes

- Jog control enables the user to manually position the antenna in the azimuth, elevation and polarization axes. The jog step increment is flashing.

Press to select FAST (1 Degree steps) or SLOW (0.1 Degree steps) jog increments.

- Press to select.

CAUTION: **IMPORTANT**

DO NOT JOG THE ANTENNA IN AZIMUTH OR POLARIZATION WHILE IN STOW.

To avoid OVERTRAVEL errors, DO NOT DRIVE THE ANTENNA BEYOND ITS TRAVEL LIMITS IN ANY AXIS

Description	Action	Display
Jog Page (Page 2.1)	From Ready Page: Main 1x Arrow 1x	Jog FAST A XXX.XX
Jog Position is now flashing. The user can select FAST or SLOW jog increments. Fast=1.0 degree/step Slow = 0.1 degree per step	+ or – then Enter	Jog FAST A XXX.XX
The azimuth position is now flashing. The user can jog the antenna by pressing + for clockwise and – for counterclockwise.	+ or – then Enter	Jog FAST 1.0 → ENT [A 0] E 0 P 0
Now the elevation position is flashing. The user can jog the antenna by pressing + for up and – for down.	+ or – then Enter	Jog FAST 1.0 → ENT A 0 [E 0] P 0
Now the polarization position is flashing. When viewed from the rear of the dish, the user can jog the antenna by pressing + for clockwise and – for counterclockwise.	+ or – then Enter	Jog FAST 1.0 → ENT A 0 E 0 [P 0]

NOTES:

1. *The antenna has a 99 step counter limit. If the antenna jogs to its limit stop and you need to go further, pres STOP then START to reset the counter to '0'. Then continue jogging the antenna.*
2. The user must press START/STOP to activate the antenna motors. The top green LED will flash when the motors are enabled.
3. DO NOT JOG THE ANTENNA IN AZIMUTH OR POLARIZATION WHILE IN STOW.
4. DO NOT DRIVE THE ANTENNA BEYOND ITS TRAVEL LIMITS IN ANY AXIS.

IMPORTANT

2.2 Satellite Parameters

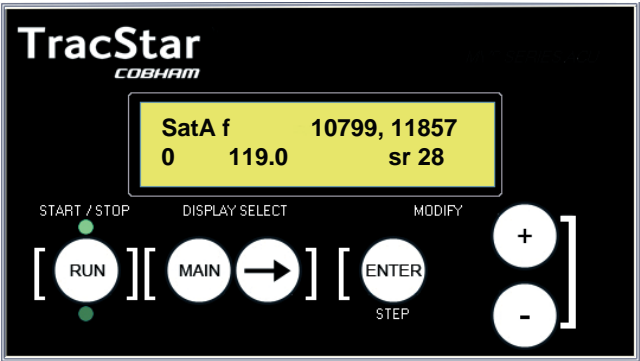

```
SatAf10799,11857
0 119.0 sr28
```

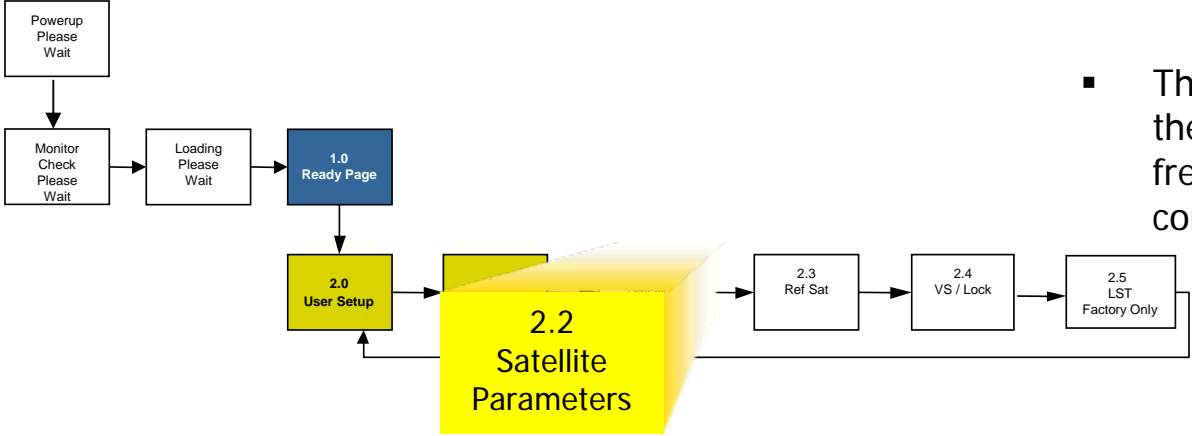

- The Satellite Parameters page allows the user to view or edit the frequencies used to acquire the communications satellite.

2.2 Satellite Parameters (con't)

Description	Action	Display
Satellite Parameters Page (Page 2.2)	From Ready Page: Main 1x Arrow 2x	SatAf10799, 10799 [0] 119 sr28
The user can toggle between SatA and SatB. To change to SatB, press + to switch to SatB. To change from SatB to SatA, press -. The orbital position of the selected satellite is displayed on the bottom row.	+ or – then Enter	SatAf10799, 10799 [0] 119 sr28
To input a new frequency for SatA press Enter then + or – to the desired frequency, then Enter. The default frequency is 10799. When the default is entered, the antenna will scan for the best frequency available.	+ or – then Enter	SatA[f10799], 10799 0 119 sr28
This is the secondary frequency and may be used by the antenna to verify lock or as a backup frequency, depending on the Lock Word (paragraph 2.4)	+ or – then Enter	SatAf10799, [10799] 0 119 sr28
sr is the symbol rate and should not be adjusted.		

2.3 Reference Satellite

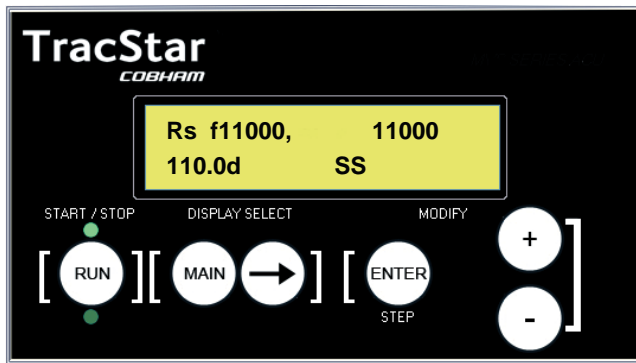

[Rs] f10799, 10799
110.0 usdvb

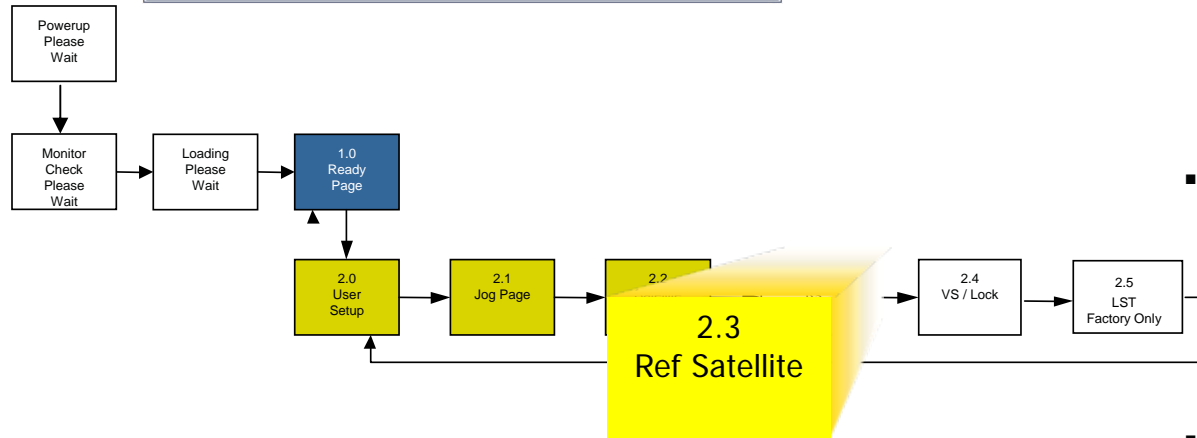

- The Reference Satellite page provides access to the available reference satellites so the user can:
 - Enter Reference Satellites
 - Delete Reference Satellites
 - Edit parameters
- Up to 12 reference satellites can be stored

2.3 Reference Satellite (con't)

Description	Action	Display
Reference Satellite Page (Page 2.3)	From Ready Page: Main 1x Arrow 3x	[Rs1] f10799,10799 XXX.X USDvB
The user can enter/edit the reference satellites from this page. When [RSX] is flashing the user can step to the next reference satellite with + or -. There can be up to 12 Reference Satellites stored. Select the desired Ref satellite number then Enter.	+ or – then Enter	[RsX] f10799,10799 XXX.X USDvB
The orbital position is now flashing and can be edited. Press + or – to the desired value, then Enter	+ or – then Enter	RsX f10799,10799 [XXX.X] USDvB
The primary frequency is now flashing. Use + or – to set the desired frequency or set to 10799 as default, then Enter. The default frequency will be automatically updated when the frequency scan is run (para. 3.2 Set Test). Over 6-8 weeks without power to the antenna, scanned frequencies may be lost unless a save to EEPROM is performed.	+ or – then Enter	Rs2 [f10799],10799 XXX.X USDvB
Continued on Next Page		

2.3 Reference Satellite (con't)

Description	Action	Display
<p>The backup frequency is now flashing. Use + or – to set the desired frequency or set to 10799 as default, then Enter. The default will be automatically updated when the frequency scan is run (para. 3.2 Set Test)</p>	<p>+ or – then Enter</p>	<p>Rs2 f10799,[10799] XXX.X USDvB</p>
<p>The user can select a scan method that uses signal strength (SS) or frequency (Freq) or USDvB to acquire the Reference Satellite.</p>	<p>+ or – then Enter</p>	<p>Rs2 f10799, 10799 XXX.X [USDvB]</p>
<p>If more Reference Satellites are desired, change to RsX then input the orbital positions and frequencies. <i>Repeat until all the applicable Reference Satellites are input.</i></p>	<p>+ or – then Enter</p>	<p>[RsX] f10799, 10799 XXX.X USDvB</p>

2.4 VS/Lock Methods

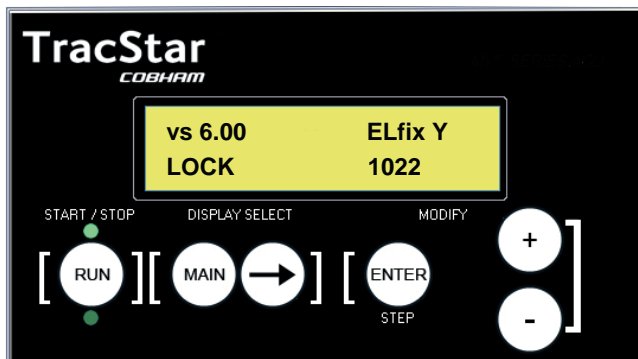

VS 6.00	ELfix Y
Lock	1022

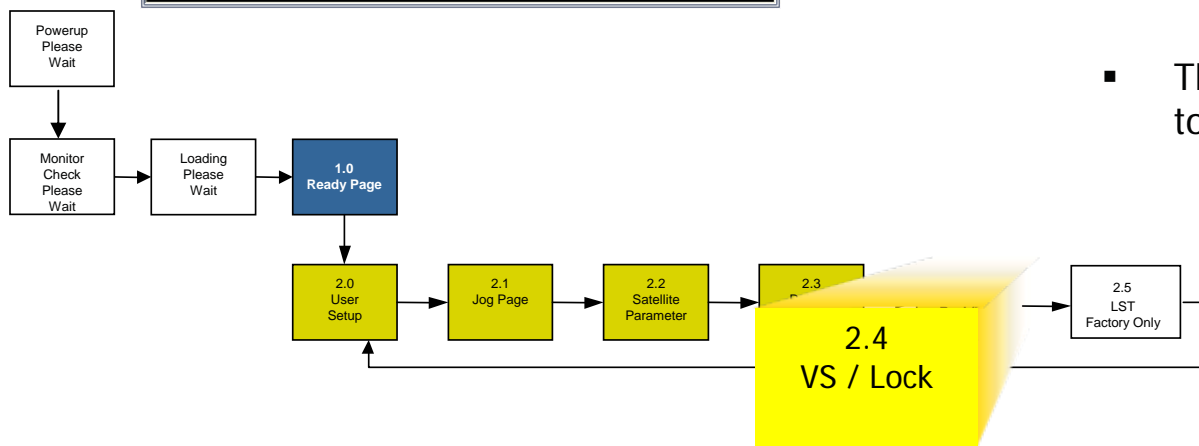

- This page gives the user the ability to:
 - change between SatA and SatB satellites without initiating a new acquisition sequence, i.e., skip the compass and reference satellite scan functions. The antenna will move directly between SatA and SatB
 - Set the Lock Method Word

- Upon Power Up the antenna will default as follows:
 - Peak: ST: As previously set
 - VS 6.00 ELfix Y – DO NOT CHANGE
 - Lock Word: As previously set

2.4 Peak/Lock Method (con't)

Description	Action	Display
The Lock Word sets the criteria by which the antenna identifies satellites. The choices are to use a transponder/carrier frequency or by signal strength. By modifying the Lock Word, certain conditions are set and must be met for the antenna to lock.	+ or – then Enter	Peak ST EI fix Y [Lock 1022]
Note: The following are valid lock words. NORMAL w/compass NO COMPASS W/DirectPoint SLOW w/compass	1233, 1133, 1036, 1022, 1032, 1023, 1222, 1233,1232,1223. 5022 and 10000 (DirectPoint Mode) 10001 10002	

NOTES:

- 5022 is for NO COMPASS REFERENCE
- All 11xx and 12xx lockwords are NOT useable with Tuner Version "B" which has no SNR ability.

Peak ST VS 6.00 ELfix Y
Lock 1022

2.4 Peak/Lock Method (con't)

0	1	0	2	2
	Reference Satellite Scan	Reference Satellite Lock Condition	Reference Satellite Frequency Condition	Data Satellite Frequency Condition
	0 = Signal Strength	0 = AGC	0 = Neither	0 = Neither
1 = DirectPoint Mode	1 = Frequency	1 = AGC & SNR	1 = SLOW w/compass	2 = F1 or F2
All Other parameters must be "0"		2 = SNR Only	2 = F1 or F2	3 = F1 and F2
			3 = F1 and F2	6 = Peak on B; Move to Sat A

Example: 1022 is a decimal word and will set the following condition for acquisition of the Reference and Data Satellite:

1022 = When the antenna is scanning for the Reference satellite, it will use the frequency from the Reference Satellite Page (2.3). Alternatively, if the digit is set to 0, the antenna will scan for the Reference Satellite using signal strength.

1022 = 0 the AGC circuit of the internal receiver is used for a satellite lock indication. If the digit = 1, the lock indication is a combination of AGC and SNR (Signal Noise Ratio) readings. If the digit = 2, the lock indication is from SNR values only.

1022 = This digit sets the condition that the antenna must find either the primary or the secondary frequency (F1 or F2) on the reference satellite in order to confirm lock. Alternatively, if the digit is set = 3, F1 AND F2 will be confirmed in order for the antenna to lock.

1022 = This digit sets the condition that the antenna must find either the primary or the secondary frequency (F1 or F2) on the reference satellite in order to confirm lock. Alternatively, if the digit is set = 3, F1 AND F2 will be confirmed in order for the antenna to lock. *

If the last digit is set to = 6, the antenna will peak on Satellite B, then swing to Satellite A. Use this for extreme cases where there appears to be no transponder on the desired data satellite.

With DirectPoint™ the Lock Method Word can be set to 10000 to enable peaking on the desired satellite (Sat A or Sat B) without using a Reference satellite. In this mode the carrier data from the modem is use solely for acquiring and peaking on the satellite.

LOCK WORDS FOR COMPASS-LESS ACQUISITION & DIRECTPOINT COMBINATION

10000 – Normal scan w/compass
10001 – No compass / DirectPoint
10002 – Slow scan w/compass

The valid lock words are: 1022, 1033, 1023, 1032, 1222, 1233, 1232, 1223, 1036 and 5022. Use 10000 for DirectPoint acquisition.*

ACU Display Layout

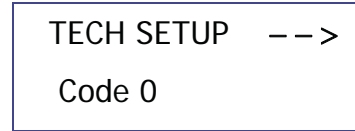
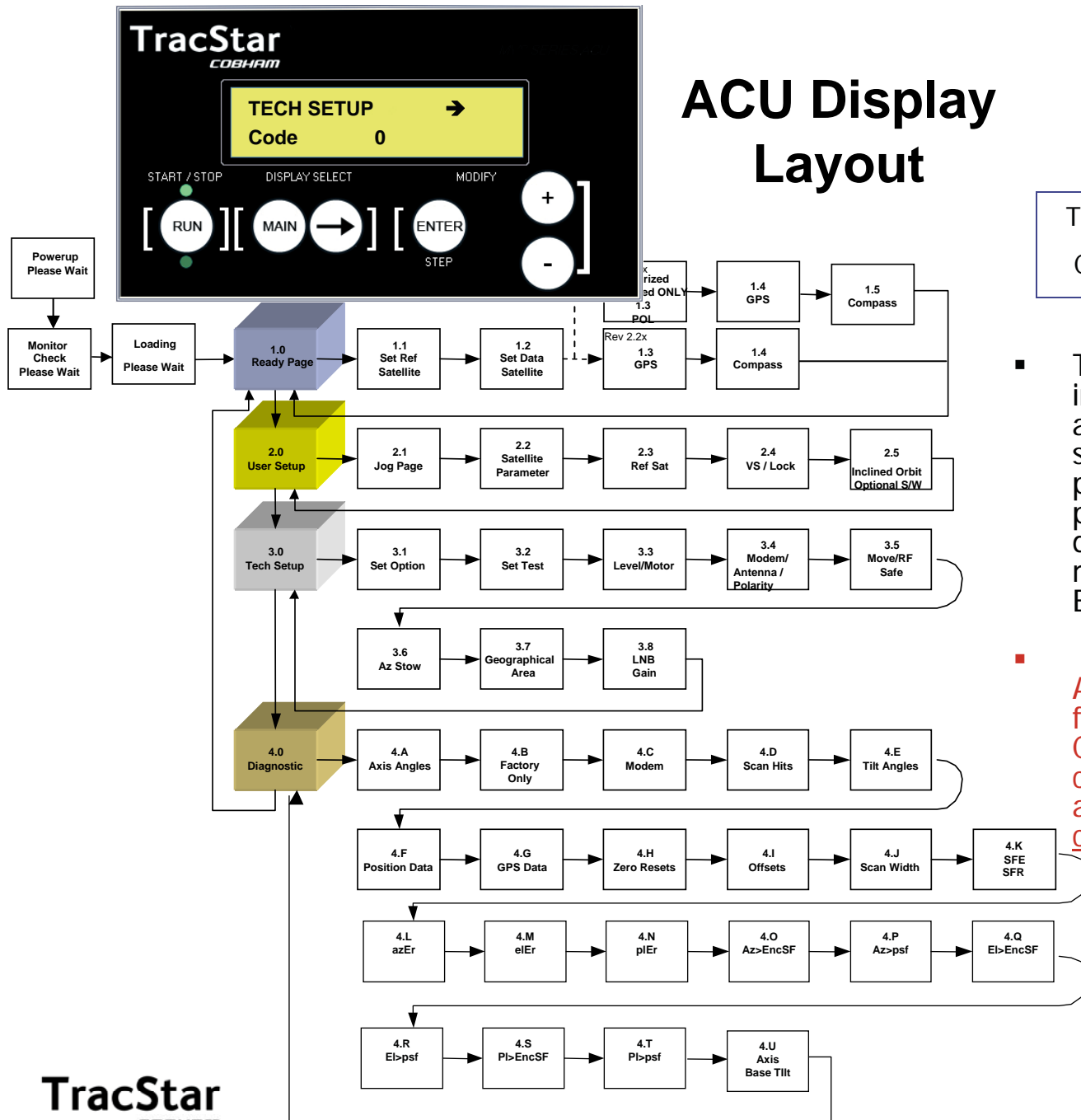

- TECH SETUP contains several interactive setup pages and the ability to enable/disable various sensors and motor drives. This page is password protected to prevent inadvertent or undesirable changes. The user must press + to Code 13, then ENTER to edit these pages.

- !! CAUTION !!**
Antennas are typically shipped fully configured for a network. Changing data in the antenna controller may render the antenna inoperable. Change controller settings with caution.



IMPORTANT

3.0 TECH SETUP (con't)

Description	Action	Display
Set Code (enables editing) (Page 3.0)	From READY page Main 2x + to code 13, Enter Main 2x	READY TECH SETUP Tech Setup CODE 13 READY

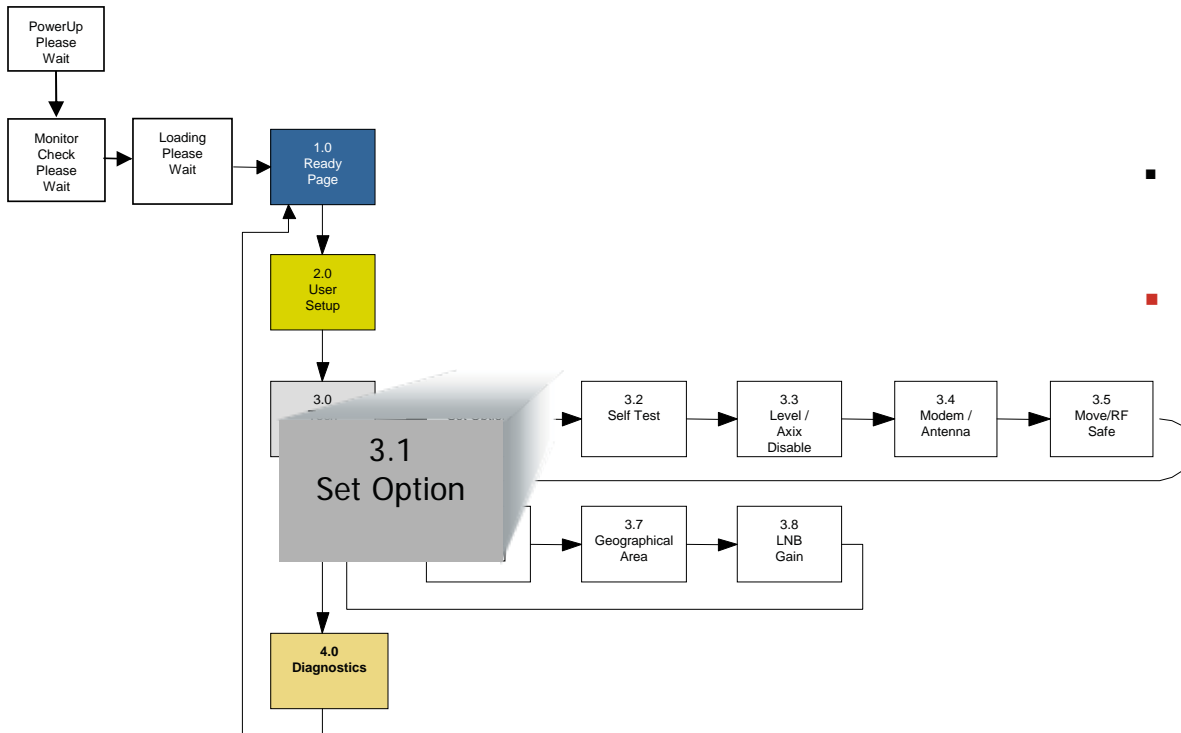
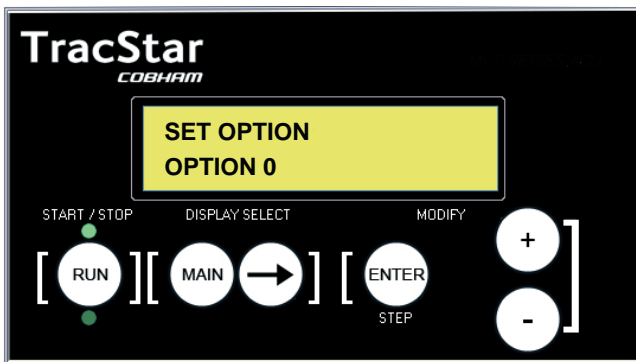

SET OPTION
[OPTION 0]

- Set Option is occasionally used for special functions by factory personnel.

!! CAUTION !!
Antennas are typically shipped fully configured for a network. Changing data in the antenna controller may render the antenna inoperable. Change controller settings with caution.



IMPORTANT

3.2 Set Test

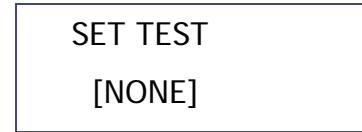
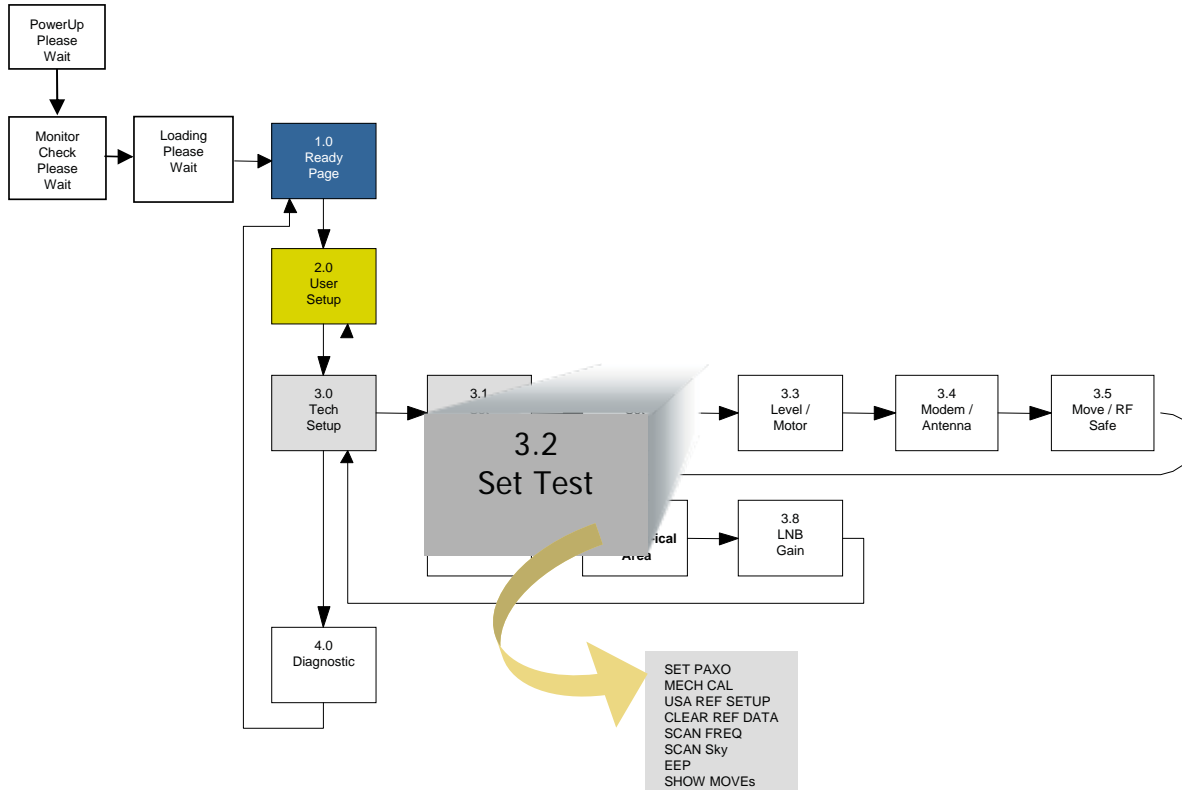
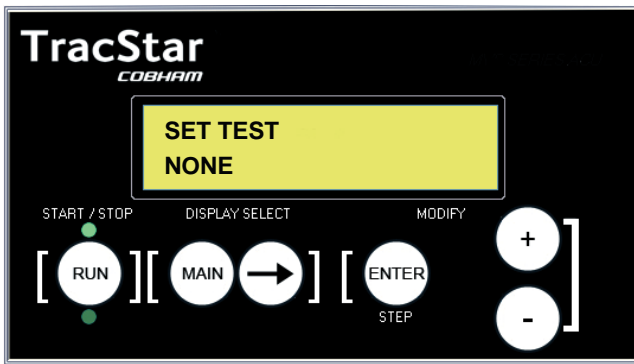

- There are several function available to the user in Set Test. Press the \oplus key to select the desired function. NOTE: The following tests do not have input parameters. They are either RUN or NOT RUN as a standard factory setup, under the direction of factory personnel.

- NONE:
- SET PAZO: Sets pol axis azimuth offset – (use when changing from factory reflector)
- MECH CAL: Mechanical self-calibration of antenna
- USA REF SETUP – Clears out data and Ref Sat locations and defaults to USAadvb settings
- CLEAR REF DATA – Clears out all SAT / Ref SAT data
- SCAN FREQ: Scans selected Reference Satellites for transponder/carrier frequencies that will be used in subsequent acquisitions.
- SCAN Sky: Scans the orbital arc for Reference Satellite positions, signal strength and frequency.
- EEP Save: Saves memory to NVEProm.
- SHOW MOVES: Pre-programmed satellite acquisition simulation.

Description	Action	Display
Set Code (enables editing) (Page 3.0)	From READY page Main 2x + to code 13, Enter Main 2x	READY TECH SETUP Tech Setup CODE 13 READY
Set Test Page (Page 3.2)	From Ready Page: Main 2x Arrow 2x	SET TEST [NONE]
Press + or – until the desired function is shown: Set PAZO – Factory Direction Only MECH CAL – Factory Direction Only USA REF SETUP – Factory Direction Only CLEAR REF DATA – Factory Direction Only SCAN FREQ – Factory Direction Only SCAN Sky – Factory Direction Only EEP Save – Factory Direction Only SHOW MOVEs – simulates antenna acquisition process for indoor demonstrations	+ or – then Enter	SET TEST [NONE]
	+ or -	SET TEST [CANCEL] SCAN FREQ
	Enter	SET TEST [RUN NOW] SCAN FREQ



3.3 Level/Motor Control Page

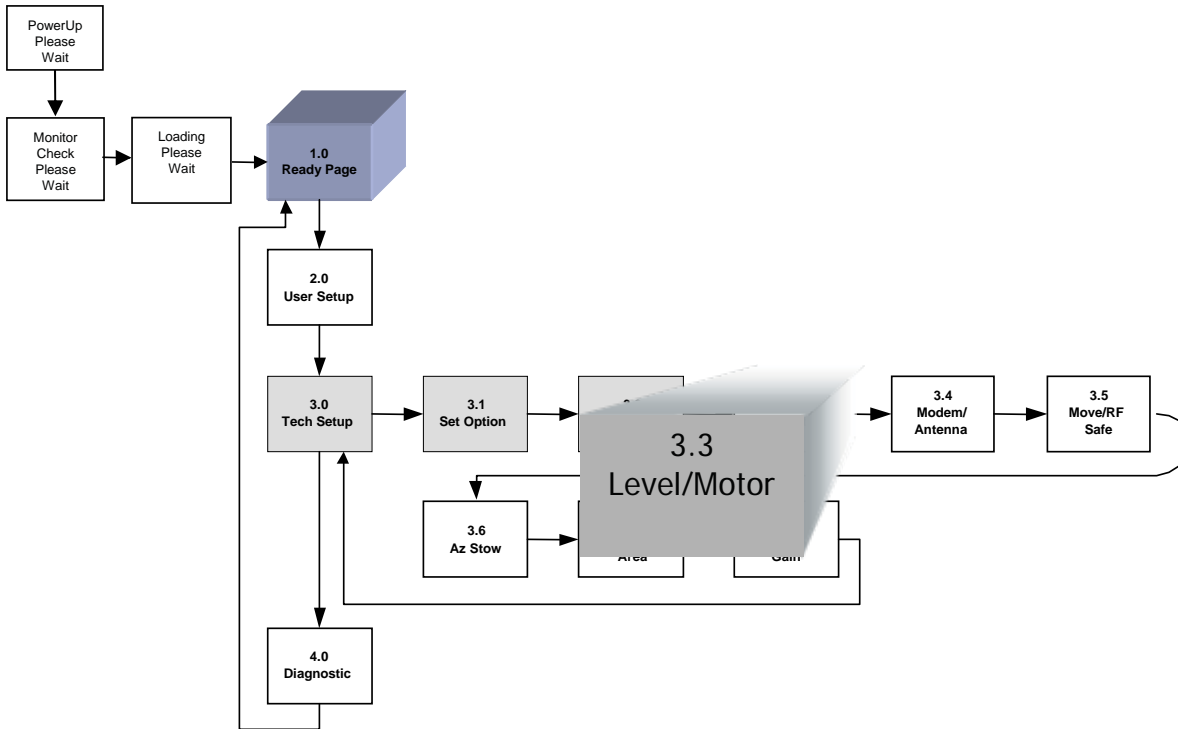
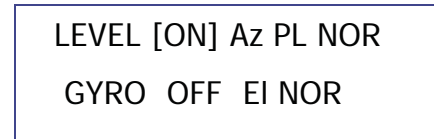

- This page gives the user the ability to turn off the base level sensor and the azimuth, elevation and polarization motors. This would normally only be performed in a troubleshooting application.
- The GYRO option is not applicable to this antenna. Default setting is OFF.

3.3 Level/Motor Control (con't)

Description	Action	Display BLUE indicates default setting
Set Code (enables editing) (Page 3.0)	From READY page Main 2x + to code 13, Enter Main 2x	READY TECH SETUP Tech Setup CODE 13 READY
Level / Motor Control Page (Page 3.3)	From Ready Page: Main 2x Arrow 3x	LEVEL [ON /OFF] Az PLNOR GYRO OFF EL NOR
The user can turn the base level sensor off, this would only be done during a maintenance or troubleshooting activity. MAY CAUSE ANTENNA ACQUISITION FAILURE.	+ or – then Enter	LEVEL [ON /OFF] Az PLNOR GYRO OFF EL NOR
The user can turn the azimuth and polarization motor off, normally only a troubleshooting function.	+ or – then Enter	LEVEL ON Az PL [NOR /DIS] GYRO OFF EL NOR
The user can turn the elevation motor off, normally only a troubleshooting function.	+ or – then Enter	LEVEL ON Az PL NOR GYRO OFF EL [NOR /DIS]

- Changes in pedestal design allow respective antennas to achieve higher elevation angles. Attempting to exceed standard elevation limits on antennas that are not modified will damage the antenna. Contact TracStar Technical Support for more information.



IMPORTANT

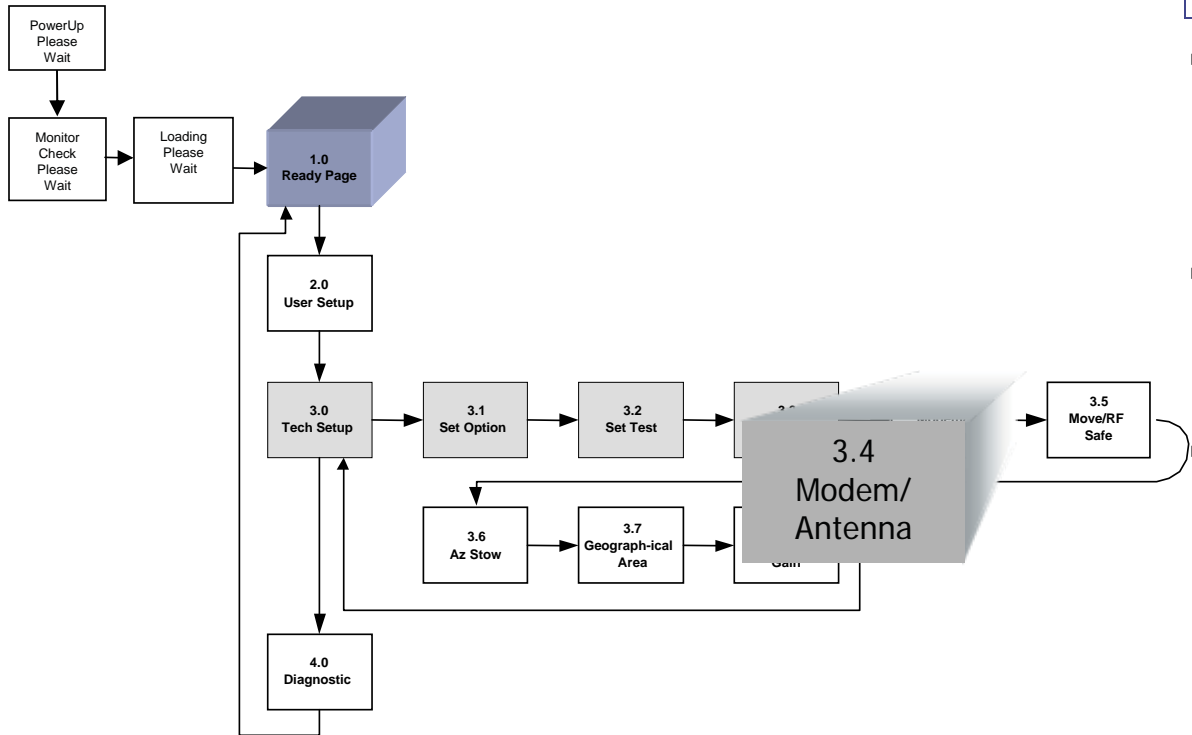
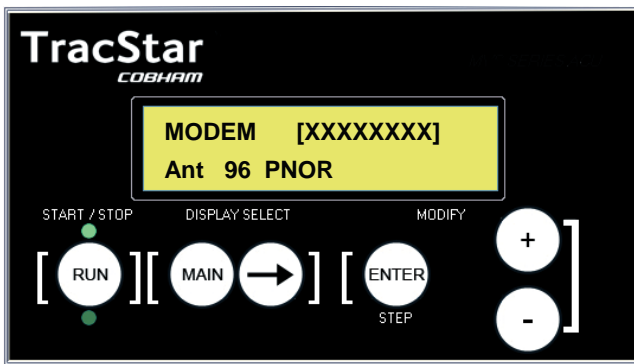

3.4 Select Modem/Antenna/Pol

2.2x SW – PNor / Prev
2.6x SW – Motor Feed

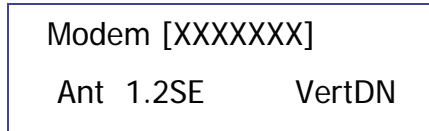

- The antenna has a serial interface for communications to selected modem types. The antenna can provide GPS information over this port.
- Press the + or – key to scroll through the pre-programmed modem models, make a selection and press ENTER.

On the TracStar1200 (1.2 Meter) and TracStar1800 Antennas with the Motorized Feed Assembly, Receive Polarization can be selected.

3.4 Select Modem/Antenna/Pol (con't)

Description	Action	Display
Set Code (enables editing) (Page 3.0)	From READY page Main 2x + to code 13, Enter Main 2x	READY TECH SETUP Tech Setup CODE 13 READY
Select Modem / Antenna Page (Page 3.4)	From Ready Page: Main 2x Arrow 4x	Modem [iDirect] Ant 96 Remove
The user can select from the following modem types for the GPS interface: None iDirect Linkstar Linkway AuxRemote	+ or – then Enter	Modem [iDirect] Ant 96 Remove
The antenna type cannot be changed without factory direction.	Contact Factory	Modem iDirect Ant 96 Remove
Motorized POL Feed Antennas ONLY		
The user can select the Receive Polarization for the antenna. Choices are: HorzDN VertDN	+ or – then Enter	[HorzDN]

MODEM TYPE	Supported Modems
NONE	Non GPS modems
iDirect *	Net Modem II Plus
Linkstar	Linkstar, EMS
Linkway	Linkway
Aux Remote	Factory
Com Tech *	Com Tech SCPC
Skylane96*	Skylane @ 9600 baud
Gilat *	SkyEdge
iNfiniti *	3000,5000, 7000 iDirect
iNfiniti IP *	ALL Lantronics Adapter Req'd
* DirectPoint Capable Modems	

3.5 Move/RF_SAFE

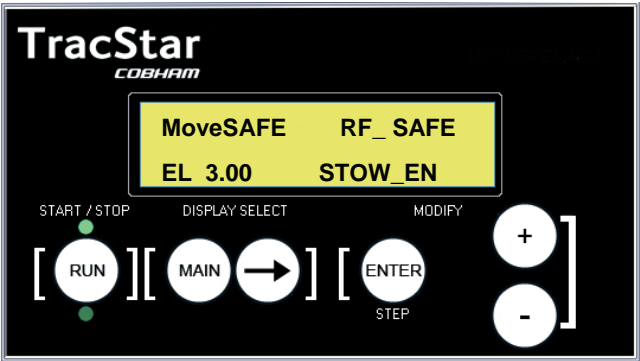

Move[SAFE] RF_SAFE
EL 3.00 Stow EN

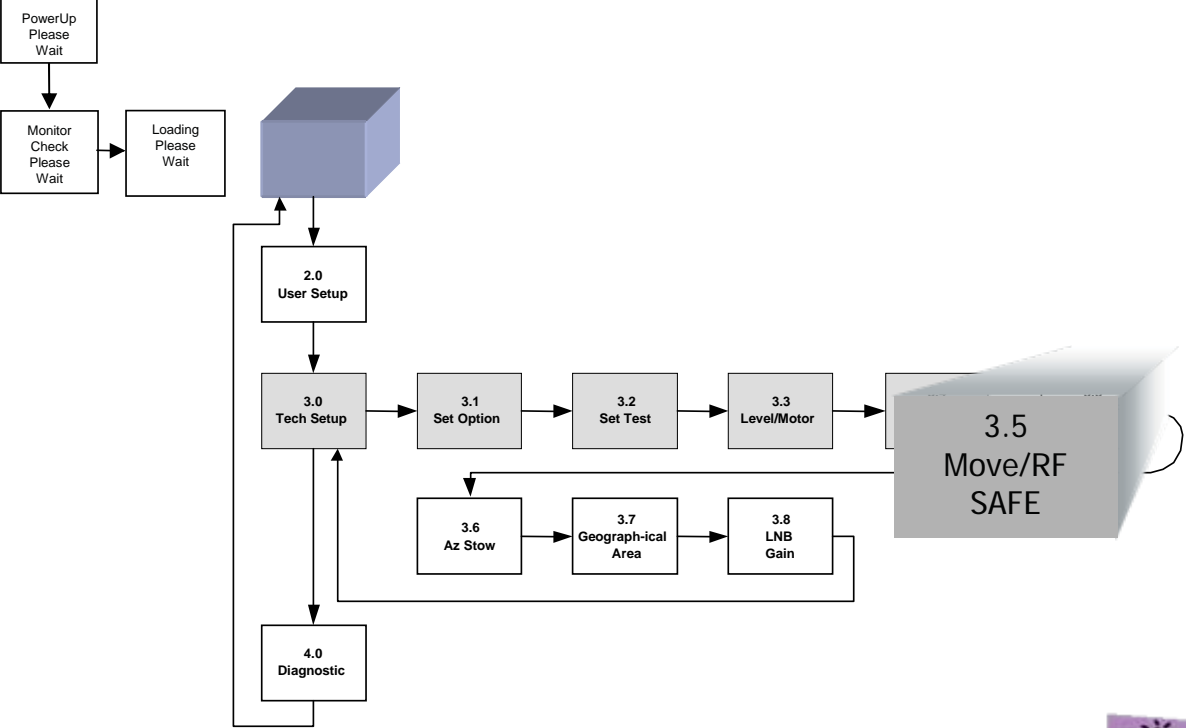

- There are several safety features built into the antenna:
- MOVE SAFE prevents any azimuth motion including jog commands below a pre-set elevation angle. This is to prevent jogging the antenna at too low of angles and possibility causing a mechanical interference.
- RF SAFE provides a Transmit Inhibit feature. If there is a motion command given to the antenna while it is locked onto a satellite, the transmitter will be inhibited prior to any motion of the antenna. The modem must have an optional DC block installed in the transmit line to be valid and for this feature to be used.
- STOW En will automatically stow the antenna IF:
 - Power is still present on the pedestal*
 - The GPS system detects movement of more than ten (10) meters.*
- Requires approx 45 seconds to complete the STOW process – Power MUST be present on the pedestal to operate.**



IMPORTANT

3.5 MOVE/RF_SAFE (con't)

Description	Action	Display BLUE indicates default setting
Set Code (enables editing) (Page 3.0)	From READY page Main 2x + to code 13, Enter Main 2x	READY TECH SETUP Tech Setup CODE 13
Move/RF/Stow Safe Page (Page 3.5)	From Ready Page: Main 2x Arrow 5x	Move [SAFE /ANY!] RF SAFE EL 3.00 Stow EN
Move [SAFE] prevents azimuth axis motion including jog commands below this pre-set limit to prevent accidental mechanical interference. Move [ANY] will disable the SAFE mode.	+ or – then Enter	Move [SAFE /ANY!] RF SAFE EL 3.00 Stow EN
RF [SAFE] will inhibit LNB power thereby inhibiting transmit if a motion command is given to the antenna via the controller. RF [ANY] will disable the SAFE mode.	+ or – then Enter	Move SAFE RF [SAFE /ANY!] EL 3.00 Stow EN
EL [X.XX] sets the low elevation angle for Move SAFE. Adjust with + or – until the desired value is reached.	+ or – then Enter	Move SAFE RF SAFE [EL 3.00 /x.xx] Stow EN
Stow [En] is the auto stow feature designed to stow the antenna in the event the GPS systems detects more than 10 meters of movement. This is a safety feature if the antenna is roof mounted and the vehicle begins to move with the antenna up. Stow [DIS] will disable the safe feature.	+ or – then Enter	Move SAFE RF SAFE EL 3.00 Stow [EN /dis]



IMPORTANT

!! WARNING !!
 “Stow EN” is NOT a failsafe solution. Ultimate responsibility falls upon the user to ensure proper antenna positioning prior to movement of the vehicle. For ultimate safety, users should install an ignition lock-out prohibiting movement of the vehicle if the antenna is deployed. TracStar assumes no responsibility for damage to the vehicle or antenna for failure to stow the antenna.

3.6 Azimuth Stow/External Switch

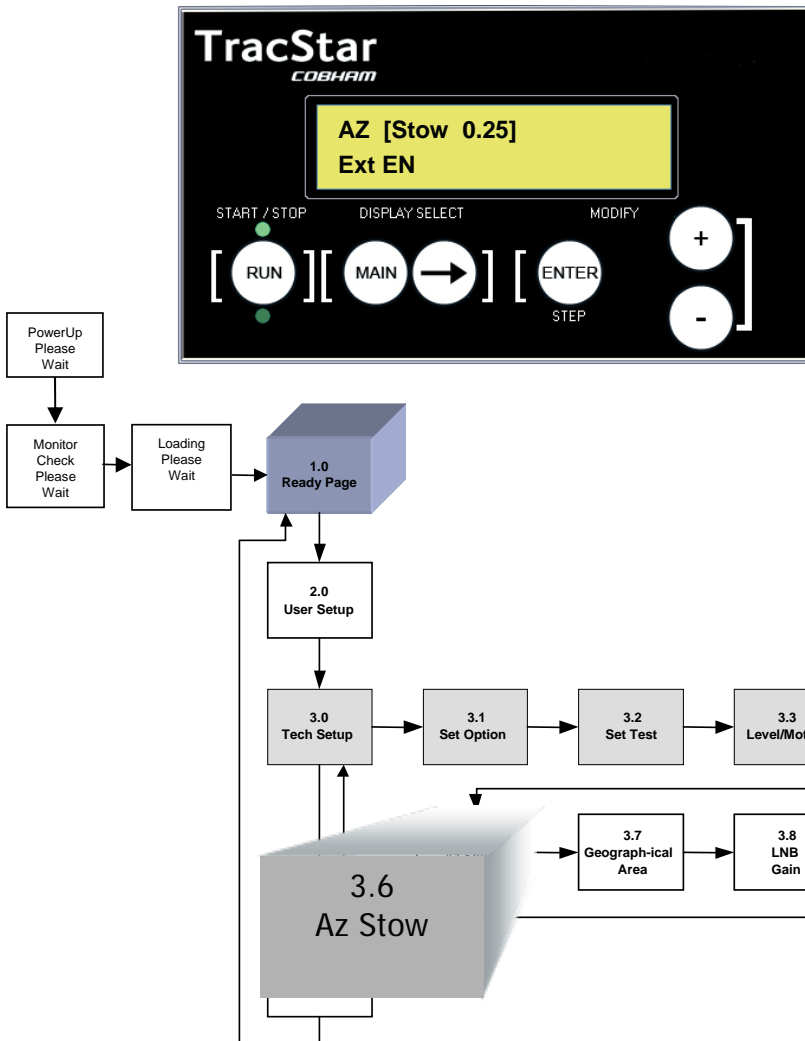

AZ [Stow 0.25]
Ext EN

- The AZIMUTH STOW setting provides the offset for the angular distance from the azimuth reference switch to the desired azimuth stow position.
- The Enable/Disable setting enables or disables the optional start/stow switch that is located on the antenna.

3.6 Azimuth Stow Setting

Description	Action	Display BLUE indicates default setting
Set Code (enables editing) (Page 3.0)	From READY page Main 2x + to code 13, Enter Main 2x	READY TECH SETUP Tech Setup CODE 13 READY
Azimuth Stow / External Switch Page (Page 3.6)	From Ready Page: Main 2x Arrow 6x	AZ [Stow 0.25] Ext EN
The azimuth stow setting determines the offset for the angular distance from the azimuth axis reference switch to the desired azimuth stow position. + or – will change the angle. This is set in the factory.	+ or – then Enter	AZ [Stow 0.25] Ext EN 
Ext EN indicates whether the pedestal start/stow switch is enabled or disabled. Press + or – to change the selection, then Enter.	+ or – then Enter	AZ Stow 0.25 Ext [EN/dis]

Az STOW is set at the factory and should not be adjusted except under guidance of factory personnel. Damage to the antenna may result from improper setting and may void warranty.

IMPORTANT

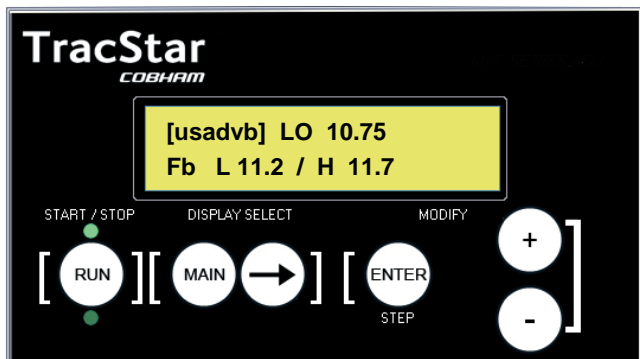

[usadvb] LO 10.75
Fb L 11.2/H 11.7

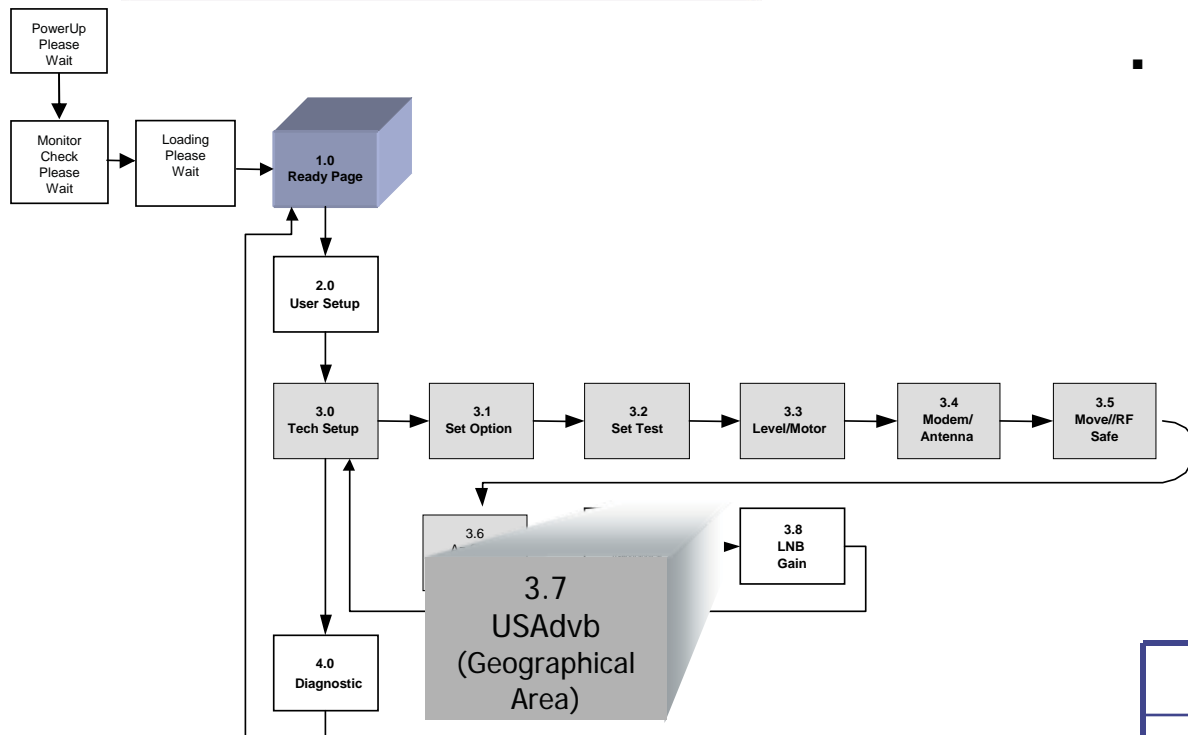

- The LNB Setup page allows the user to:
 - Select the region of the world that the antenna is located in
 - Input the local oscillator frequency of the LNB in use
 - Input the receive frequency band corresponding to the frequency band and LNB in use.
 - Note: these are the frequencies that are used during the antenna scan.

LNB BANDS		
		Ku Band GHz
LO	C	11.2 – 11.7
MID	A	11.7 – 12.2
HIGH	B	12.2 – 12.7

Description	Action	Display BLUE indicates default setting
Set Code (enables editing) (Page 3.0)	From READY page Main 2x + to code 13, Enter Main 2x	READY TECH SETUP Tech Setup CODE 13
LNB Setup Page (Page 3.7)	From Ready Page: Main 2x Arrow 7x	[USAdvb] LO 10.75 Fb L 11.2/H 11.7
The antenna must be set to USA, USAdvb, Mid East or Europe. Press + to edit then Enter. <i>USAdvb is the preferred setting in the USA, due to the type of satellite typically used as a reference. Mid EAST and EUROPE have the same internal software functions, either will work in either location.</i>	+ or - then Enter	[USAdvb] LO 10.75 Fb L 11.2/H 11.7 
Set the LNB Local Oscillator frequency using + or -, then Enter	+ or - then Enter	Mid East [LO 10.75] Fb L 11.2/H 11.7
Set the low end of the frequency band in use with + or -, then Enter.	+ or - then Enter	Mid East LO 10.75 Fb [L 11.2]/H 11.7
Set the high end of the frequency band in use with + or -, then Enter	+ or - then Enter	Mid East LO 10.75 Fb L 11.2/[H 11.7]

IMPORTANT

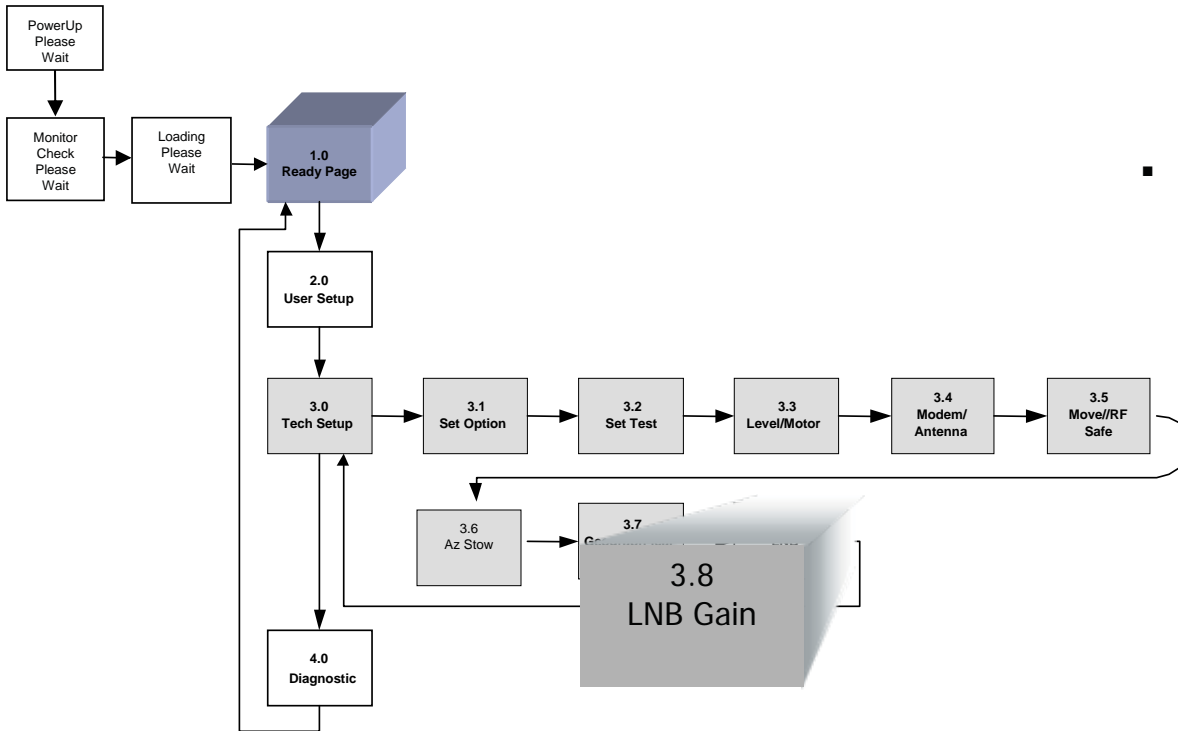
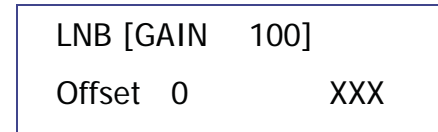
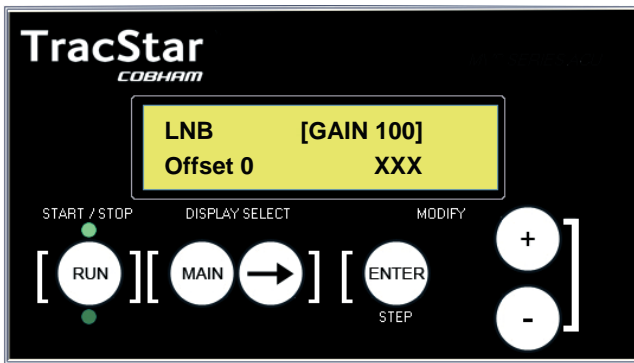

- The LNB Gain page allows the user to:
 - Adjust the gain of the LNB as seen by the antenna controller's built in signal strength measurement (SS).
 - Enter a LNB noise offset as seen by the antenna controllers built in signal strength measurement (SS).

Description	Action	Display BLUE indicates default setting
Set Code (enables editing) (Page 3.0)	From READY page Main 2x + to code 13, Enter Main 2x	READY TECH SETUP Tech Setup CODE 13
LNB GAIN Page (Page 3.8)	From Ready Page: Main 2x Arrow 8x	LNB [GAIN 100] Offset 0 XXX
The user may wish to adjust the LNB gain as measured by the built in tuner: Gain = 100, nominal setting Gain = 50, ½ of nominal gain Gain = 200, double the nominal gain When adjusting the gain, monitor the signal strength number in the lower right. Increasing the gain will increase the signal level.	+ or – then Enter	LNB [GAIN 100] Offset 0 XXX
The user may wish to adjust the LNB offset as measured by the built in tuner. Adjust the offset when the antenna is pointed at a cold sky. Adjusting the offset should minimize the signal strength number when the antenna is looking at cold sky.	+ or – then Enter	LNB GAIN 100 [Offset 0] XXX



4.0 DIAGNOSTICS PAGE

DIAG No LOG ==>
St XX ssXX YYY

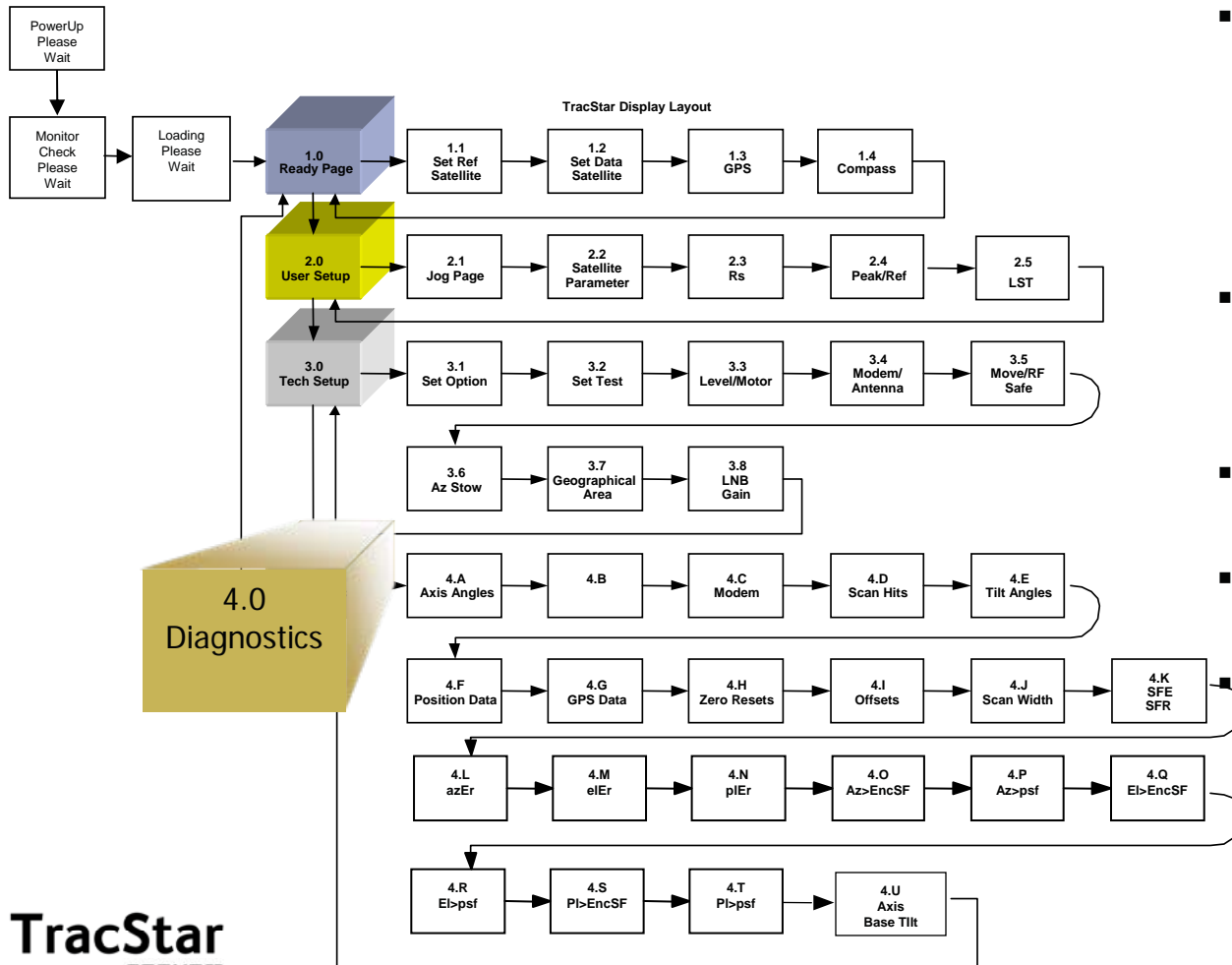

- The Diagnostics section includes information on antenna pointing angles, level sensor readings, GPS data and the ability to set correction factors for the three axes.
- “No LOG” and “LOG try” are messages unique to Idirect Series Modems requiring a log-in process.
- St XX indicates the tracking state of the antenna.
- ssXX composite signal strength.
YYY is tuned signal strength.

4.A Axis Angles

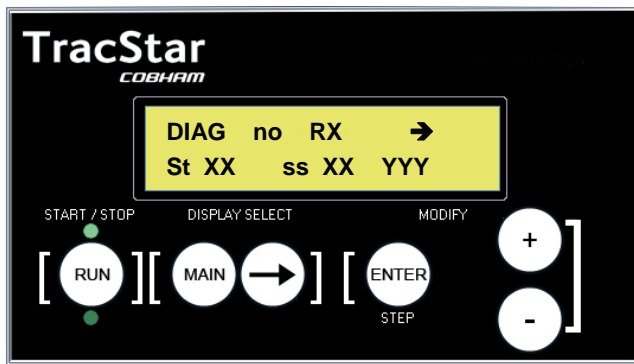

A 246.00 E 28.70
Ap 44.6 Ep 27.77

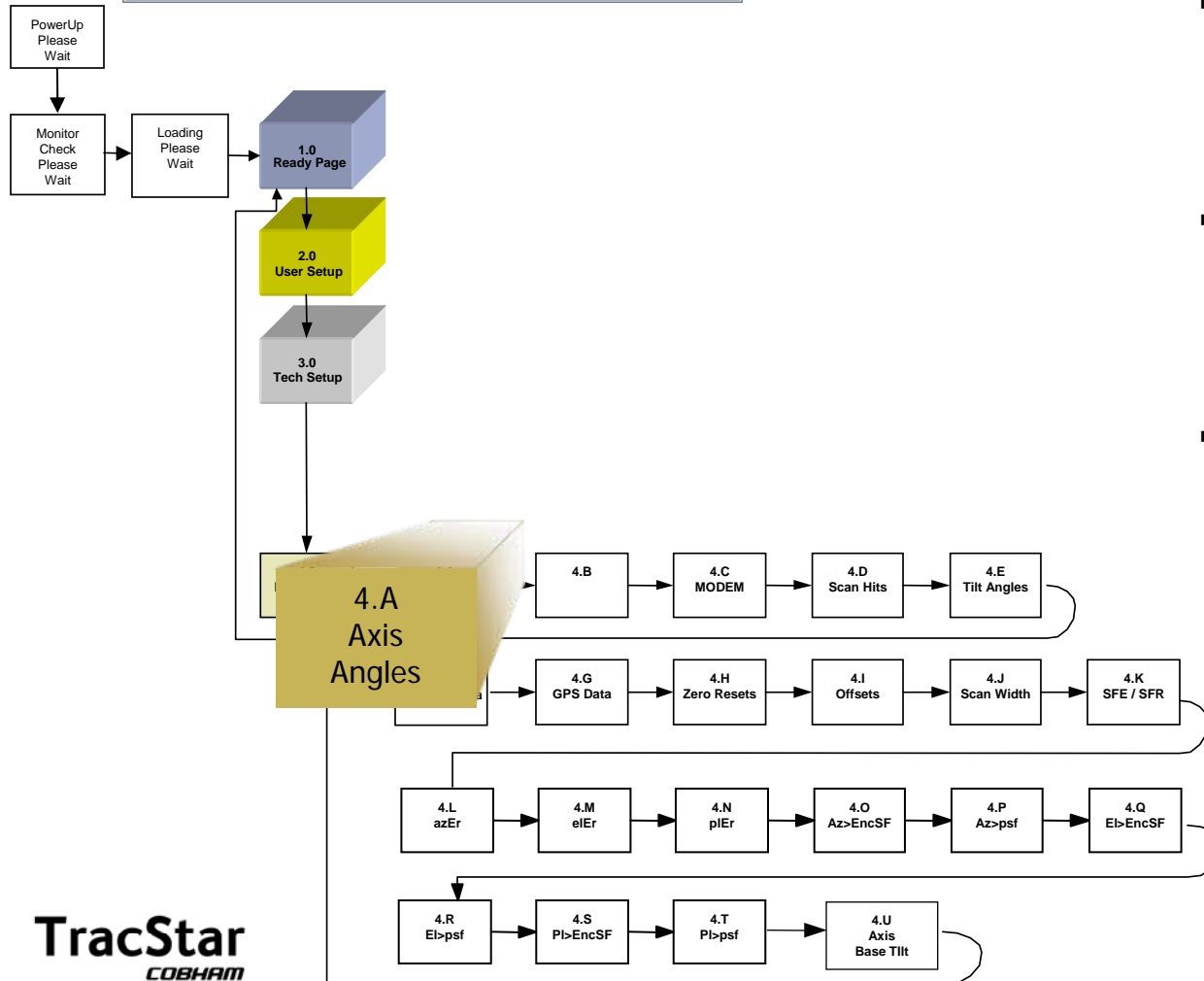

- The DIAGNOSTICS A page indicates the azimuth and elevation angles of the antenna.
- The top row shows the antenna Az and El angles relative to the earth (azimuth only valid after lock on)
- The second row Ap and Ep indicate the Az and El angle relative to the pedestal coordinates, i.e., the azimuth stow angle is zero degrees. El is only valid above -10 degrees.

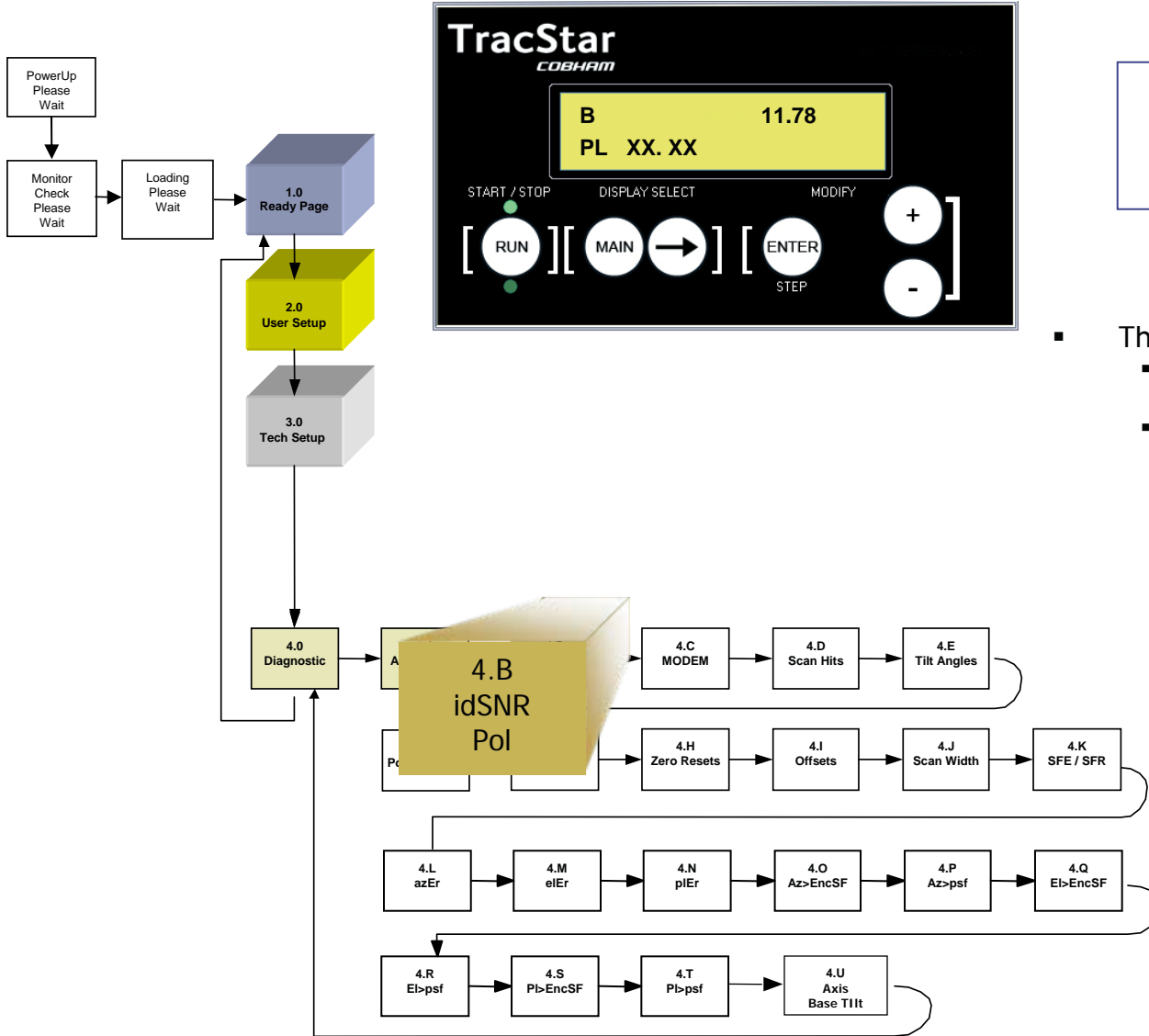

- The DIAGNOSTICS B page displays:
 - The polarization angle of the antenna
 - The Signal / Noise Ratio for DirectPoint Modems

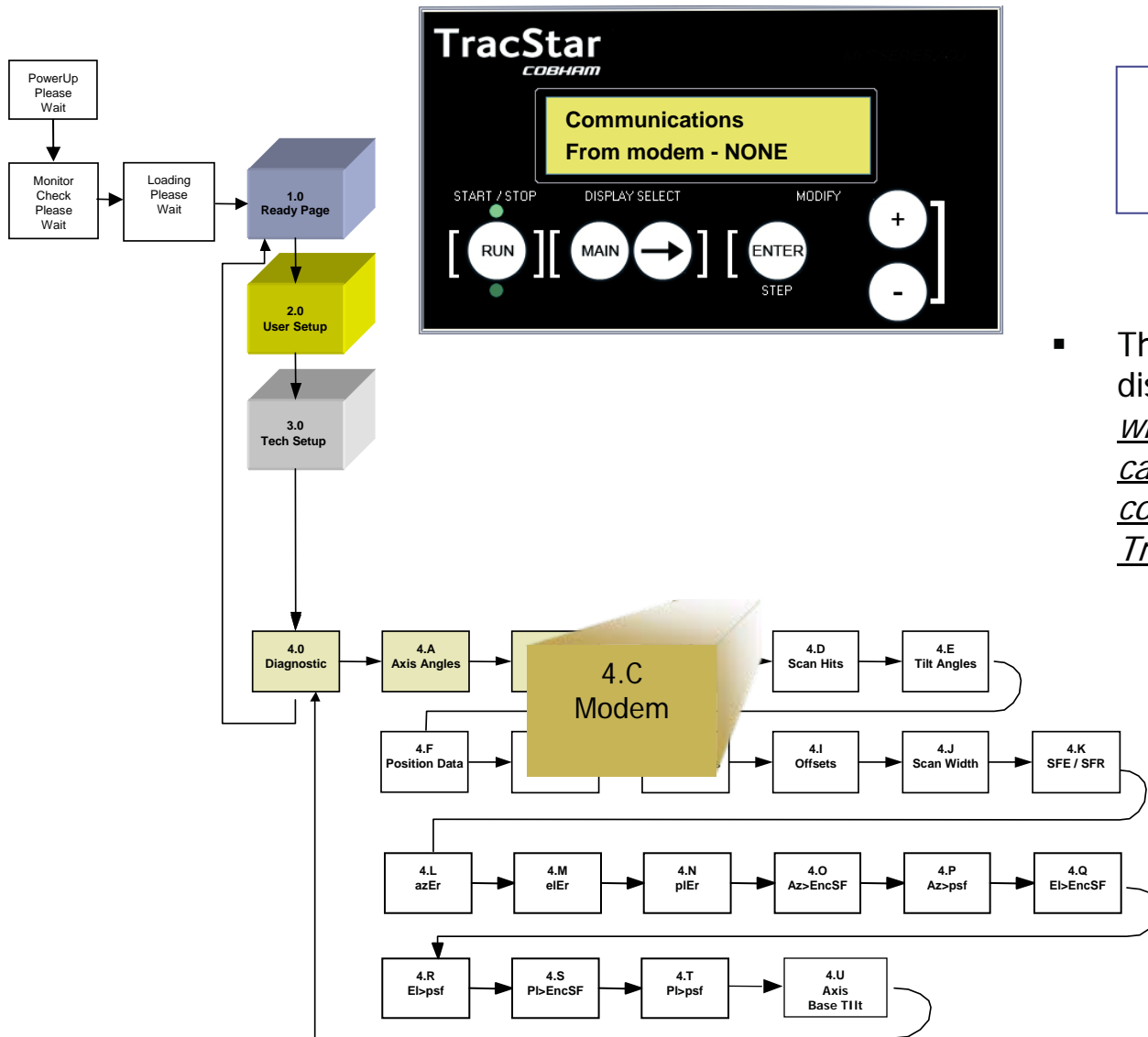

Communications
from modem-NONE

- The DIAGNOSTICS C page displays modem messages when connected to modems capable of two-way communication with the TracStar controller only.



```
2125082 0000000
0000000 0000000
```

- The DIAGNOSTICS D page indicates satellites that were “seen” during the acquisition and alignment of the antenna.
- Each of the four groups of seven digits is as follows:
 - 1st - 3 digits - azimuth angle (example 212)
 - Next two digits - elevation angle (example 50)
 - Last two digits signal – strength (example 82)

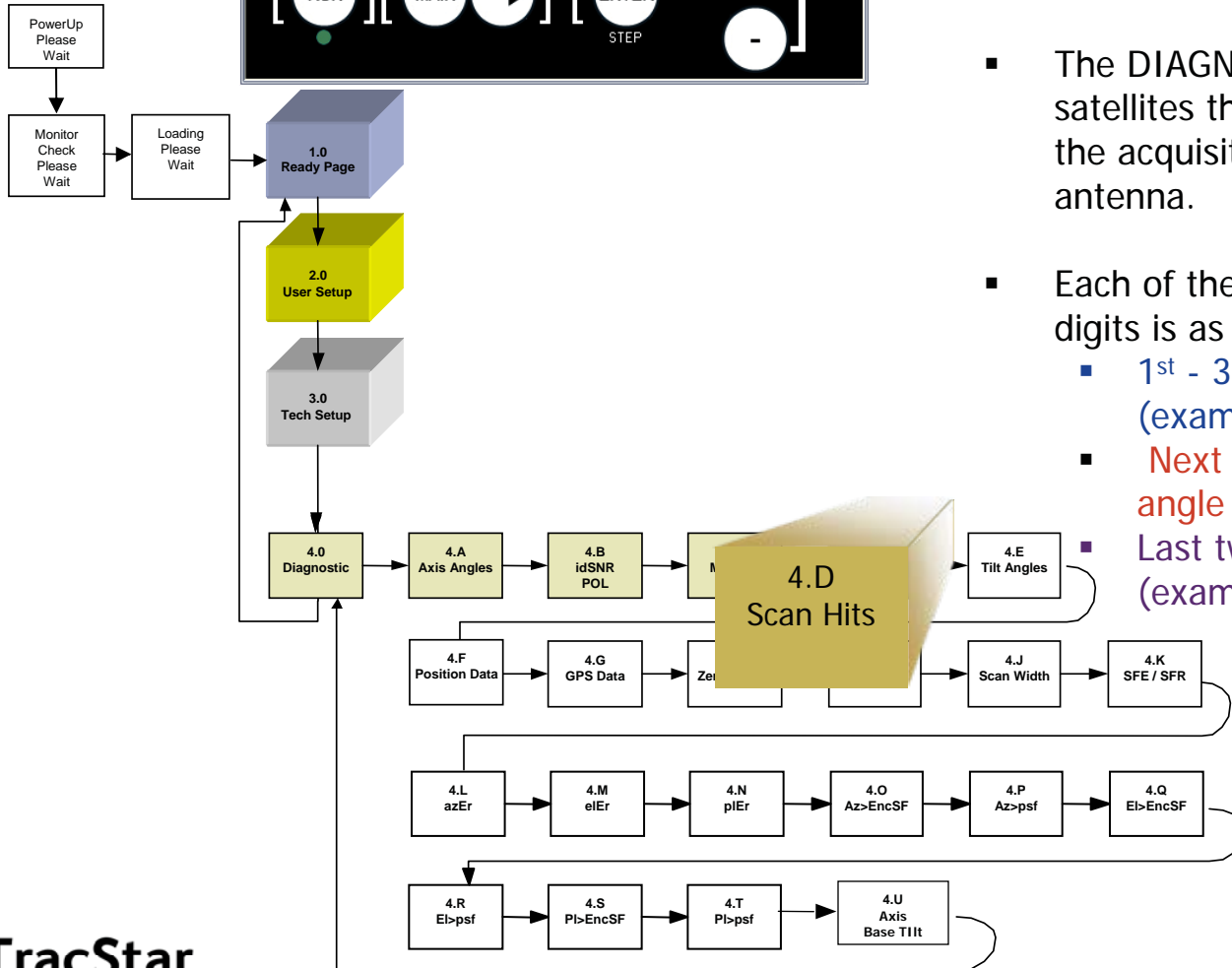

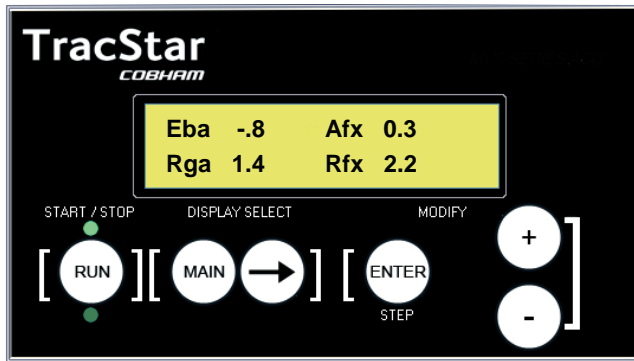

Eba 0.8 Afx 0.3
Rba 1.4 Rfx 2.2

Elv 4.0 Afx 1.7
Rlv 1.5 Rfx 1.4

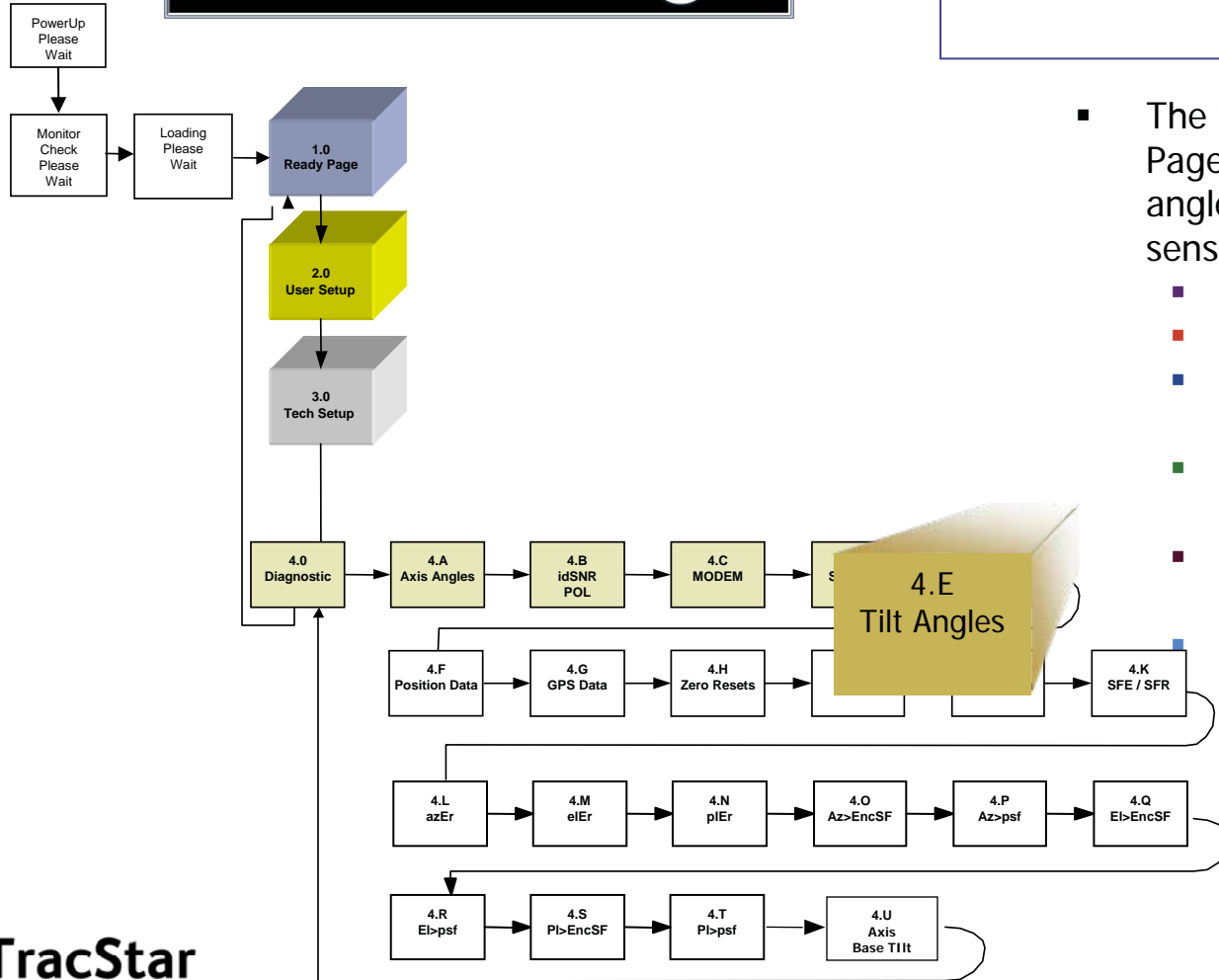

- The values on the DIAGNOSTICS E Page are the pedestal base tilt angles as measured by the tilt sensor.
 - Eba = elevation base angle
 - Rba = roll base angle
 - Afx = azimuth adjustment due to base tilt
 - Rfx = pol adjustment due to base tile
 - Elv = raw (unfiltered) el base angle reading
 - Rlv = raw (unfiltered) roll level reading

4.F Axis Position Transducer Readout

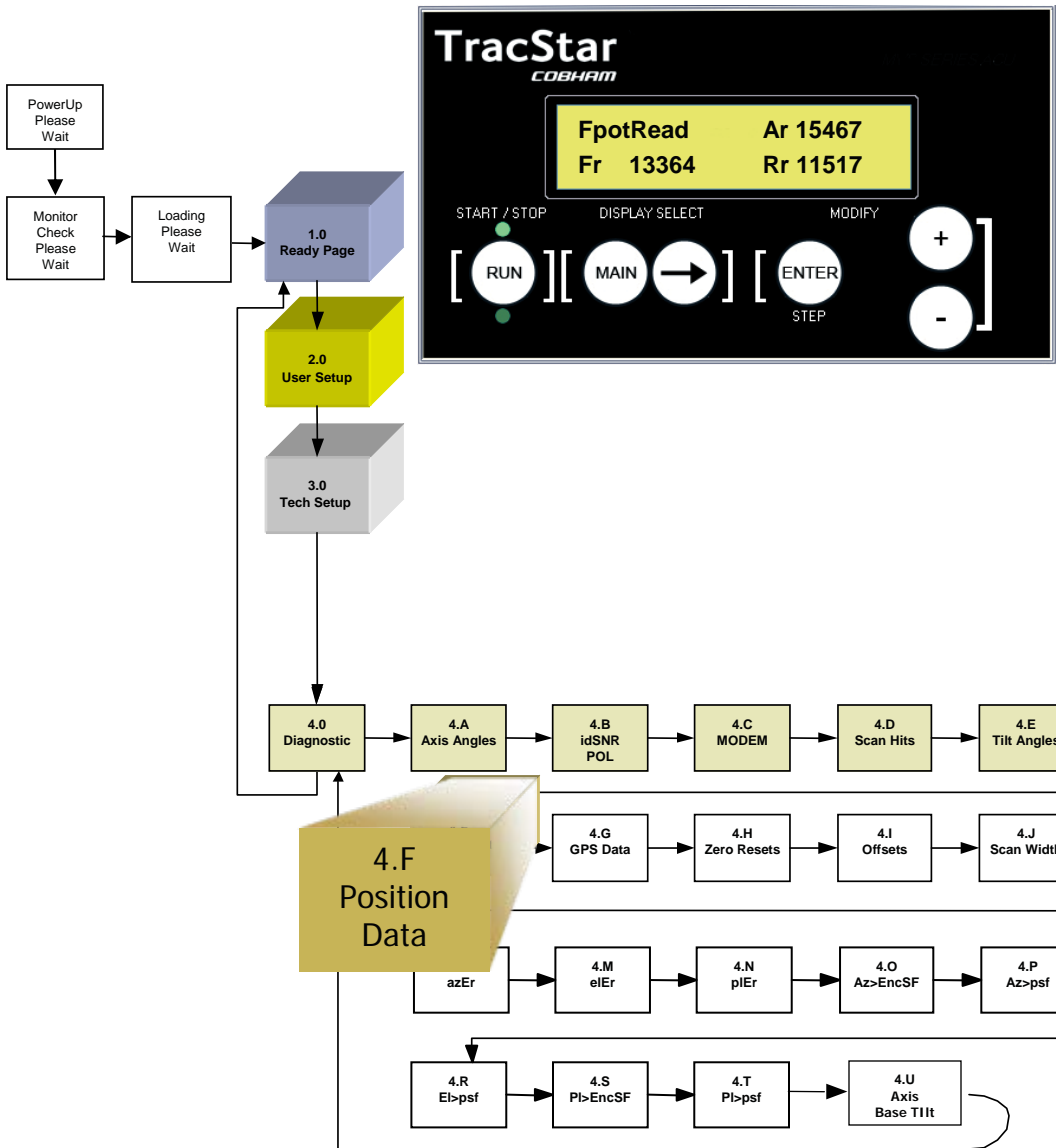

FpotRead	Ar15467
Er 13364	Rr11517

- The DIAGNOTICS F page is the analog position transducer reading from the azimuth and elevation axis.
- Ar = azimuth reading
- Er = elevation reading
- Rr = POL reading on antennas with motorized feeds

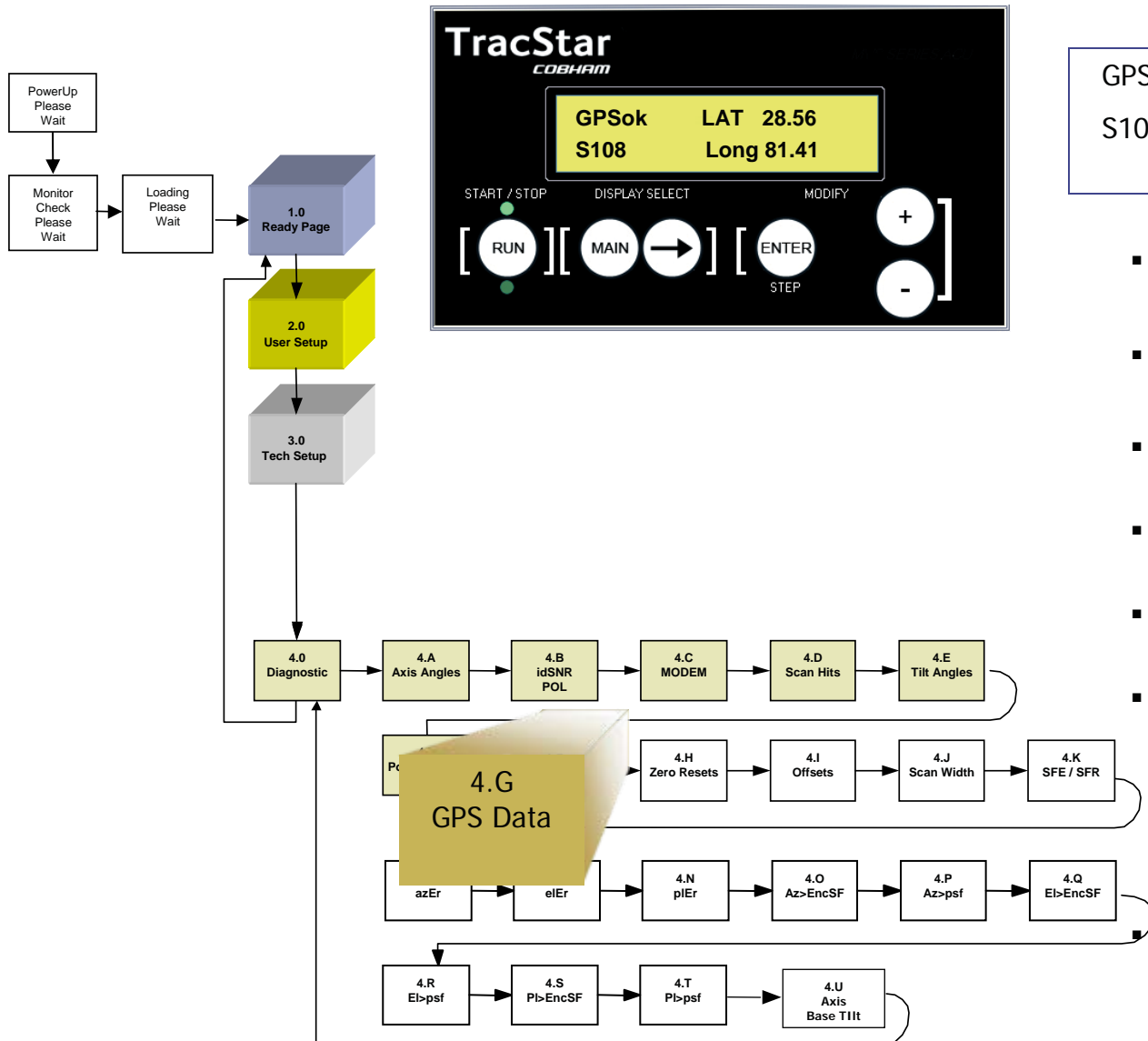

GPSok LAT 28.56
S108 Long 81.41

- The DIAGNOSTICS G page provides the GPS data as follows:
- GPSok indicates the GPS signal is acquired
- LAT 28.56 indicates the current latitude of the antenna.
- GVelocity indicates a change of antenna movement/location
- MagD 5.10 indicates the magnetic deviation
- S108 - Digit (placeholders shown)
 - 1 - indicates if the unit has ever received GPS lock
 - 0 - indicates the unit has not received GPS on this power up
 - 1 - indicates the unit has received GPS on this power up
 - 8 - number of GPS satellites currently being received
- Long 81.41 gives the longitude position of the antenna.

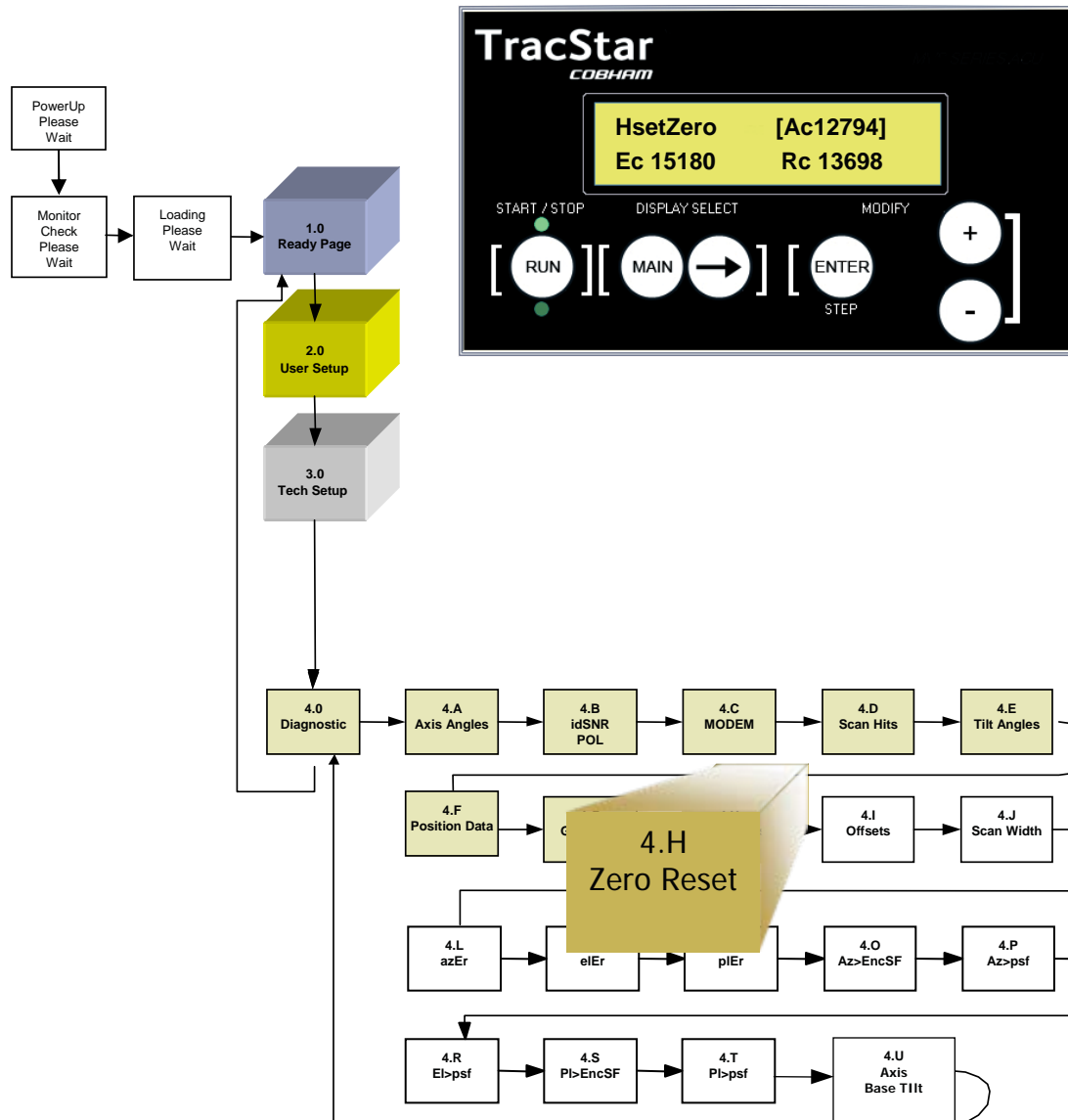

HsetZero [Ac12794]
Ec15180 Rc13698

- **DO NOT CHANGE without assistance from factory personnel**
- The DIAGNOSTICS H page allows the user to set the center value for each of the transducers as seen on the F page.
- Ac is the azimuth center value used to set azimuth 0 degree angle (stow position).
- Ec is the elevation center value used to set elevation 45 degree angle.
- Rc used on antennas with motorized feed system

4.1 Axis Offsets

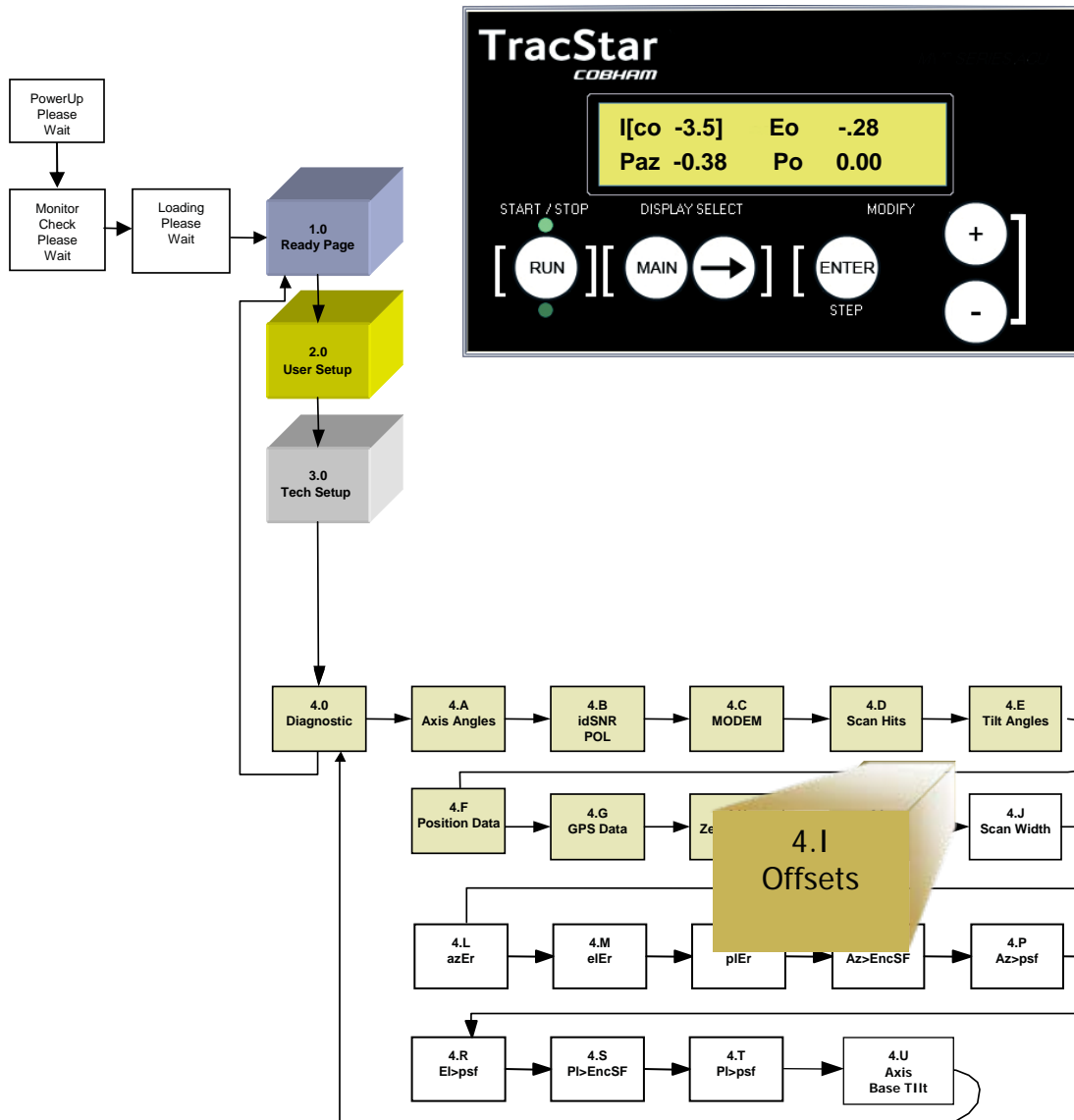

I[co -3.5] Eo -.28
Paz -0.38 Po 0.00

- The DIAGNOTICS I page allows the user to view and set offsets in degrees for each axis.
- Co is the compass offset, this correction is self learning and updates itself on each acquisition.
- Eo is the elevation offset after each acquisition.
- Paz is the boresight offset for the RF beam.
- PO is the polarization adjustment for peaking co/x pol adjustments

4.1 Axis Offsets (con't)

Description	Action	Display
Set Code (enables editing) (Page 3.0)	From READY page Main 2x + to code 13, Enter Main 2x	READY TECH SETUP Tech Setup CODE 13
Axis Zero Offsets Page (Page 4.9)	From Ready Page: Main 3x Arrow 9x	I [co -3.5] Eo -.28 Paz -.30 Po 0.00
Co is the compass offset and updates automatically after each acquisition. The user should not change this value.	Enter	I [co -3.5] Eo -.28 Paz -.30 Po 0.00
Paz is the boresite offset for the RF beam. This value is set in test and should not be changed by the user.	Enter	I co -3.5 Eo -.28 [Paz -.30] Po 0.00
Po is an offset for the polarization axis. An offset can be permanently input by the user if necessary. Code 13 allows for up to 8 degrees of offset. If offset requires more than 8 degrees of adjustment, contact Tech Support	+ or – then Enter	I co -3.5 Eo -.28 Paz -.30 [Po 0.00]

4.J Azimuth Scan Width

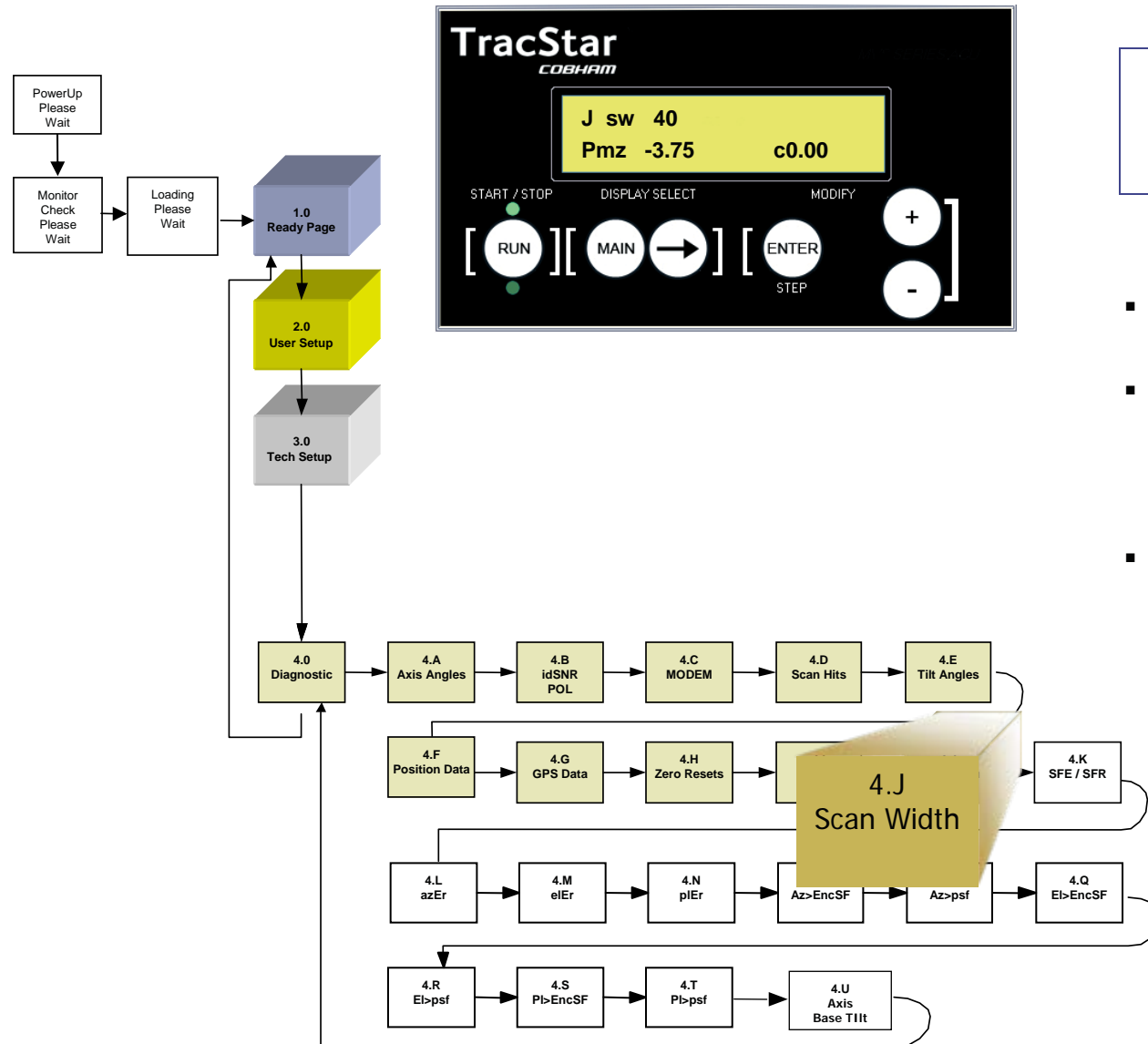

J sw 40

pmz -3.75 c 0.00

- DO NOT CHANGE without assistance from factory personnel
- The Diagnostics J page allows the user to set the width of the azimuth scan during the initial reference satellite acquisition.
- The default value is 40.0 degrees.
 - The max value is 100 degrees
 - The min value is 10 degrees.

4.J Azimuth Scan Width (con't)

Description	Action	Display
Set Code (enables editing) (Page 3.0)	From READY page Main 2x + to code 13, Enter Main 2x	READY TECH SETUP Tech Setup CODE 13
Azimuth Scan Width Page (Page 4.10)	From Ready Page: Main 3x Arrow 10x	[Sw 40.00] pmz -3.75
The user can adjust the azimuth scan width from 10 to 100 degrees. 40 is the default.	+ or – then Enter	[Sw 40.00] pmz -3.75

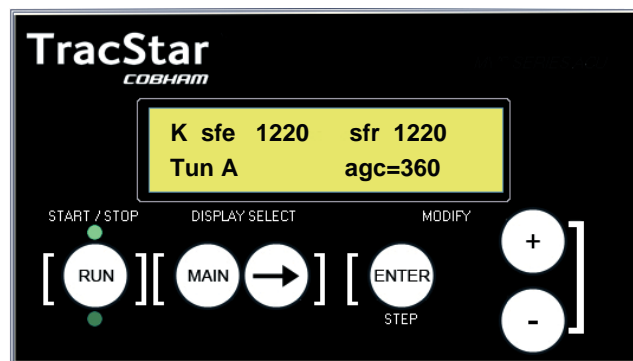

```

K sfe1220   sfr1220
Tun A      magc=1600
    
```

- These values are the base angle level span calibrations for the e (elevation) and r (roll) tilt.
- Items can NOT be edited from the ACU
- Tun indicates Tuner 'A' or 'B' style is installed in the system
 - AGC of internal tuner
 - MAGC – additional gain boost during acquisition on smaller pedestals
 - With Tun B – SNR Lock word is unavailable

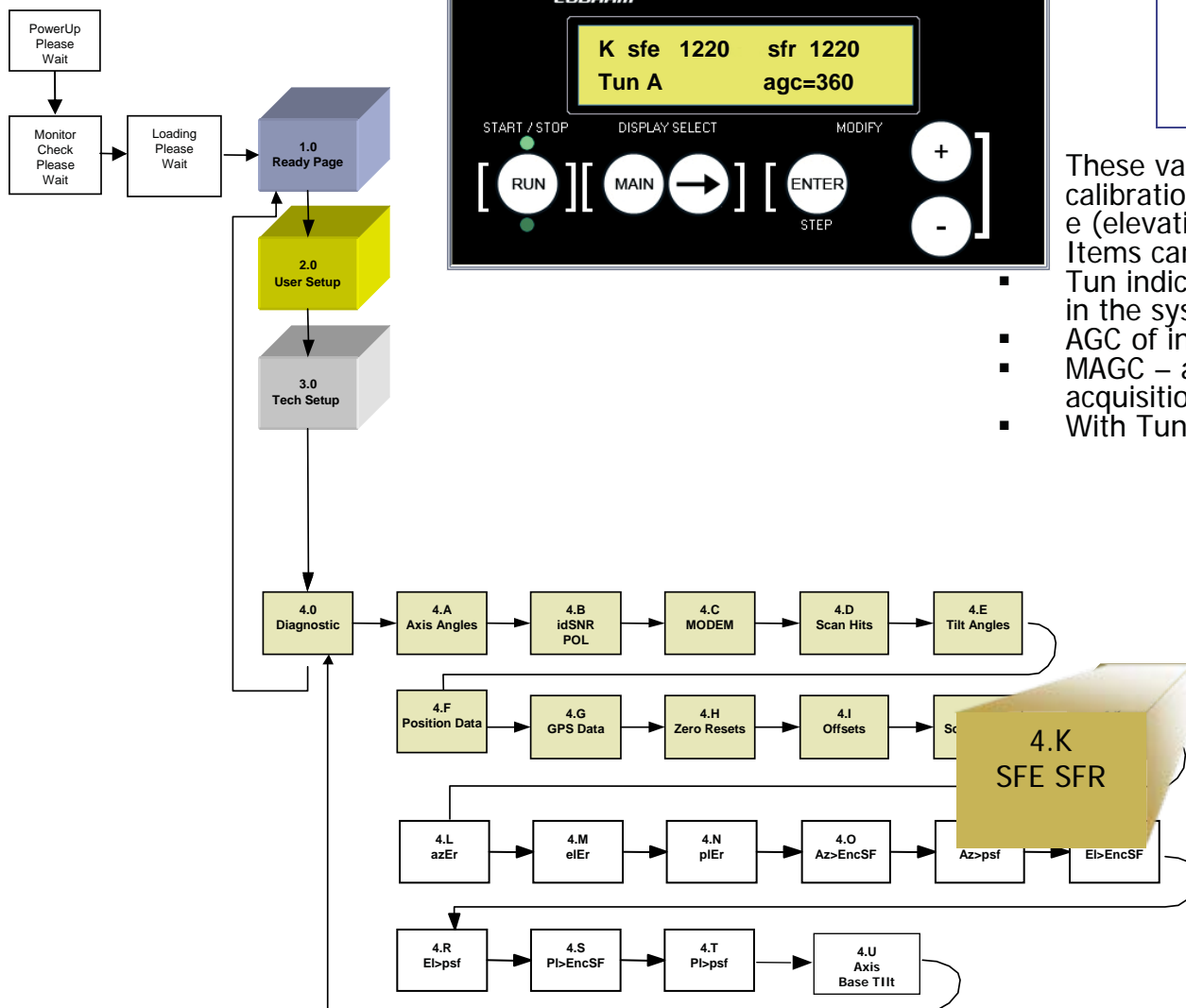

4.L Axis Diagnostics

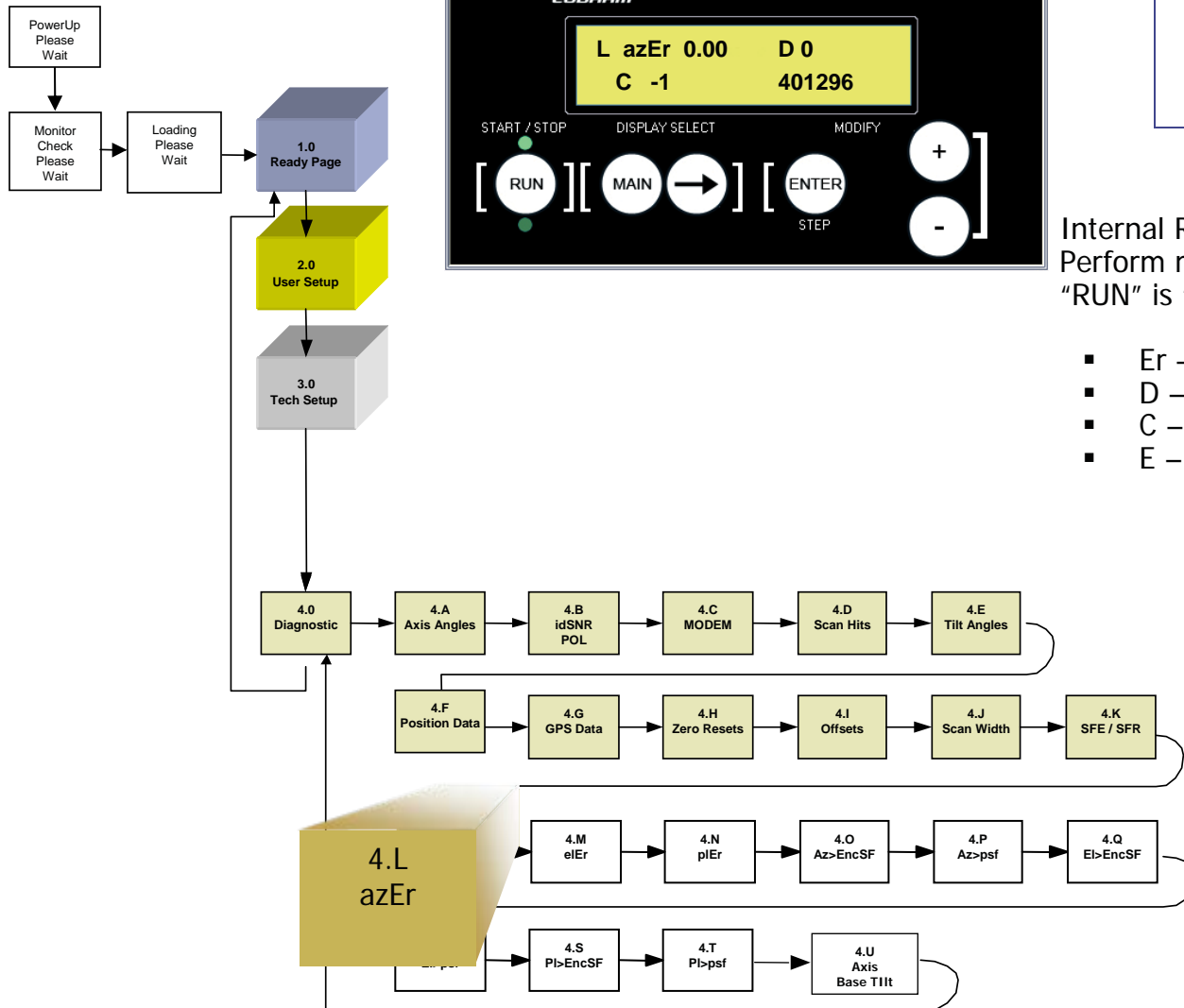

LazEr	0.00	D	0
C	-1		401296

Internal Readings from azimuth axis.
 Perform manual jog of the azimuth axis when "RUN" is 'on' and +/- buttons are depressed.

- Er – Servo Position Error
- D – DAC Value +/- 120
- C – Current Value +/- 100
- E – Encoder Counts

4.M Axis Diagnostics

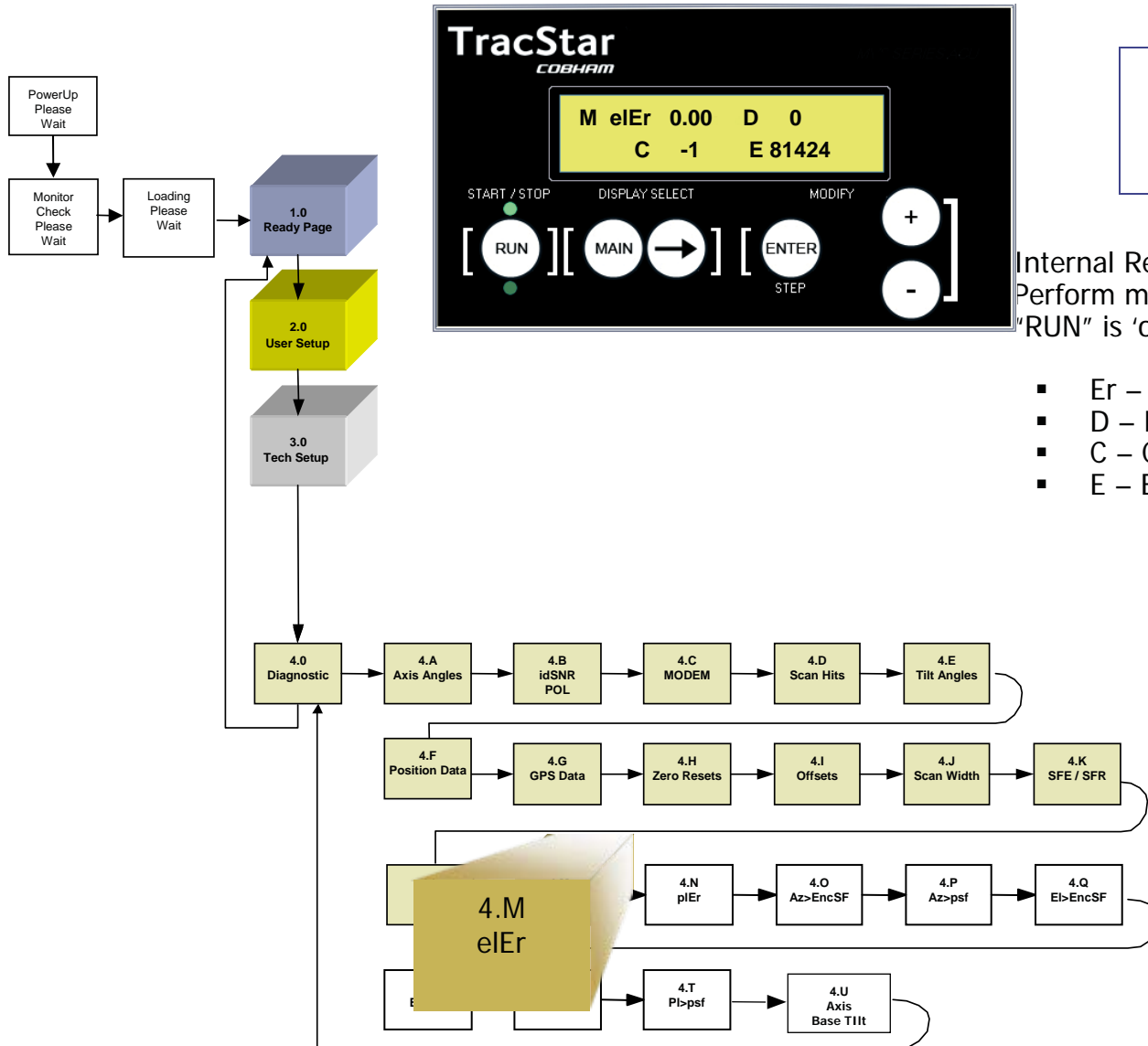

MeEr	0.00	D	0
C	-1	E	81424

Internal Readings from elevation axis.
 Perform manual jog of the azimuth axis when "RUN" is 'on' and +/- buttons are depressed.

- Er – Servo Position Error
- D – DAC Value +/- 120
- C – Current Value +/- 100
- E – Encoder Counts

4.N Axis Diagnostics

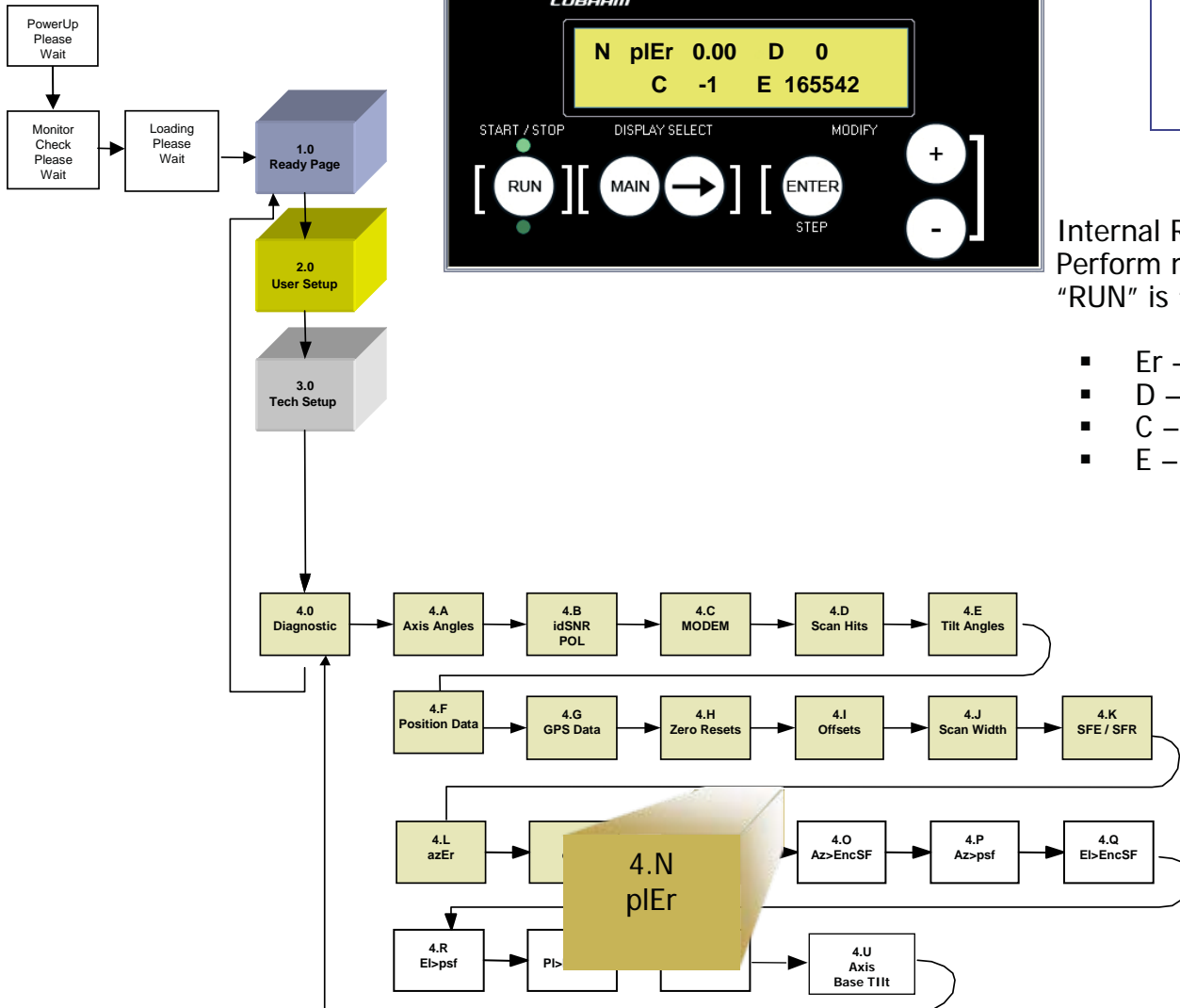

N pIer	0.00	D	0
C	-1	E	165542

Internal Readings from pole axis.
 Perform manual jog of the azimuth axis when
 "RUN" is 'on' and +/- buttons are depressed.

- Er – Servo Position Error
- D – DAC Value +/- 120
- C – Current Value +/- 100
- E – Encoder Counts

4.0 Axis Diagnostics

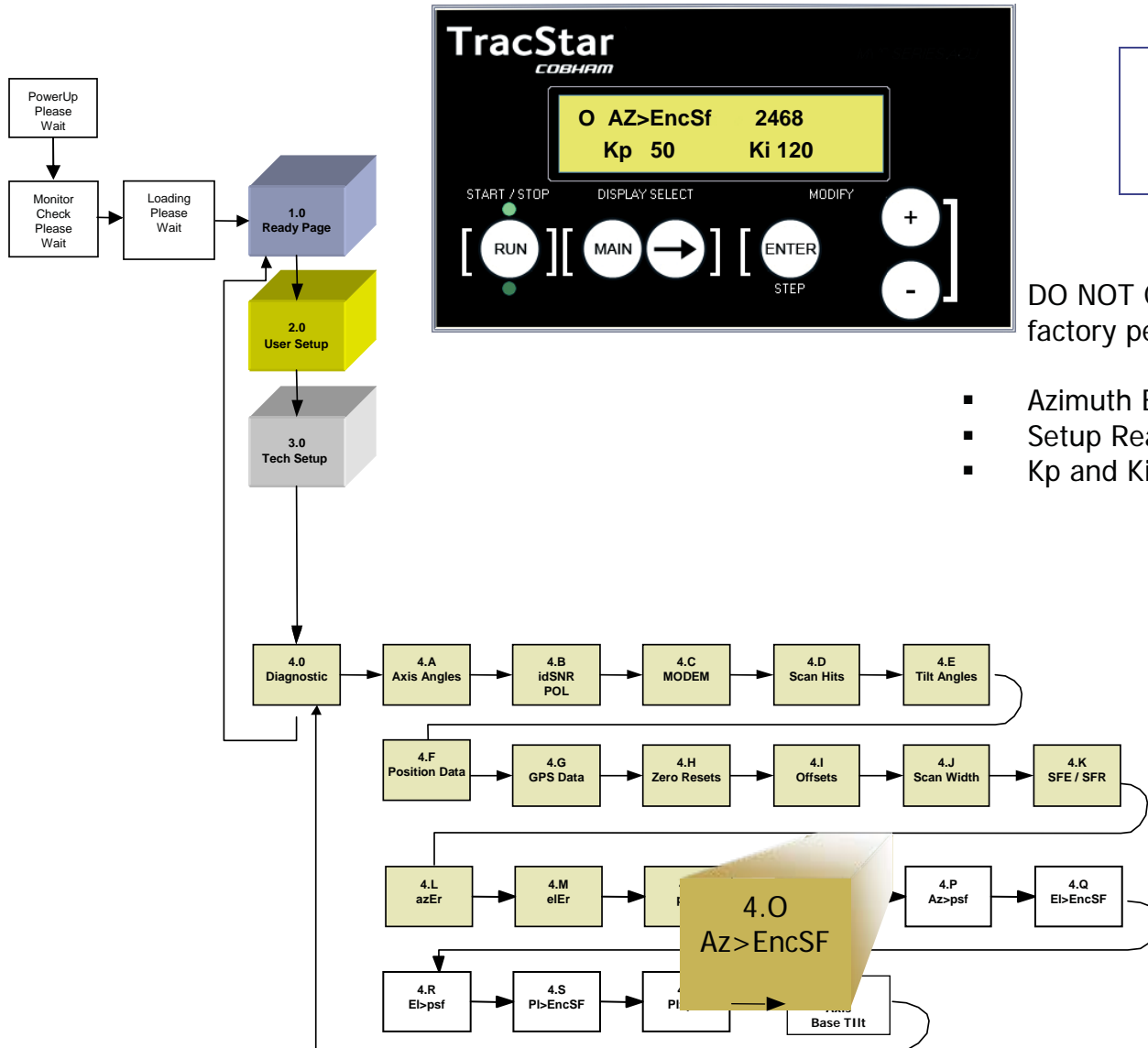

O AZ>EncSf	2468
Kp 50	Ki 120

DO NOT CHANGE without assistance from factory personnel

- Azimuth Encode Scale Factor
- Setup Readings for Azimuth Axis
- Kp and Ki are servo loop data

4.P Axis Diagnostics

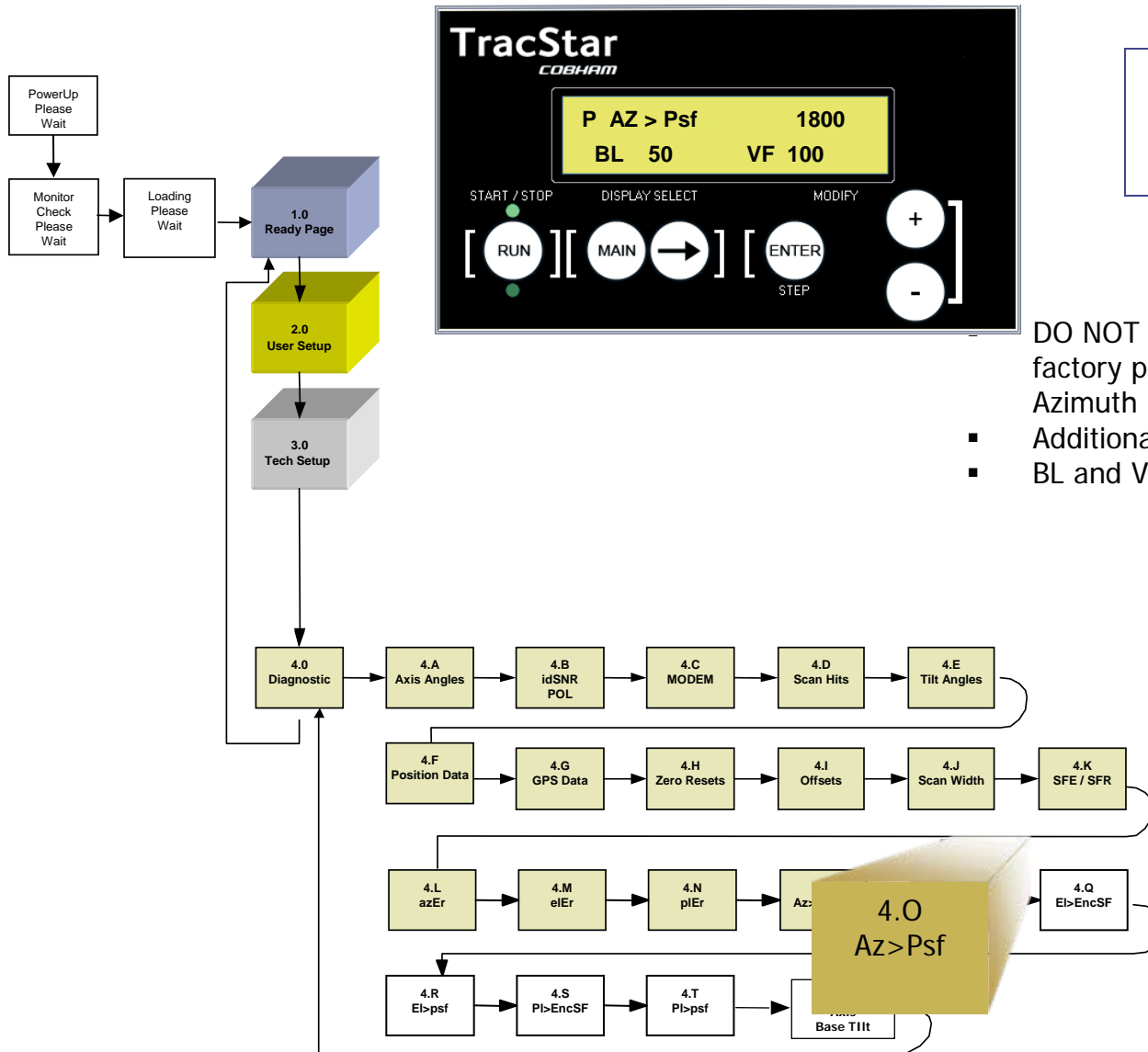

P AZ > Psf	1800
BL 50	VF 100

- DO NOT CHANGE without assistance from factory personnel
- Azimuth Pot Scale Factor
 - Additional Setup Readings for Azimuth Axis
 - BL and VF are servo parameters

4.Q Axis Diagnostics

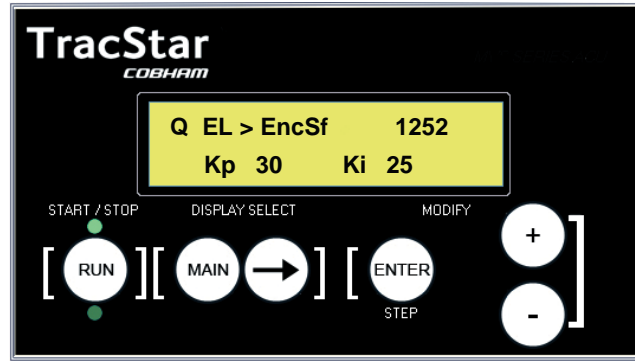
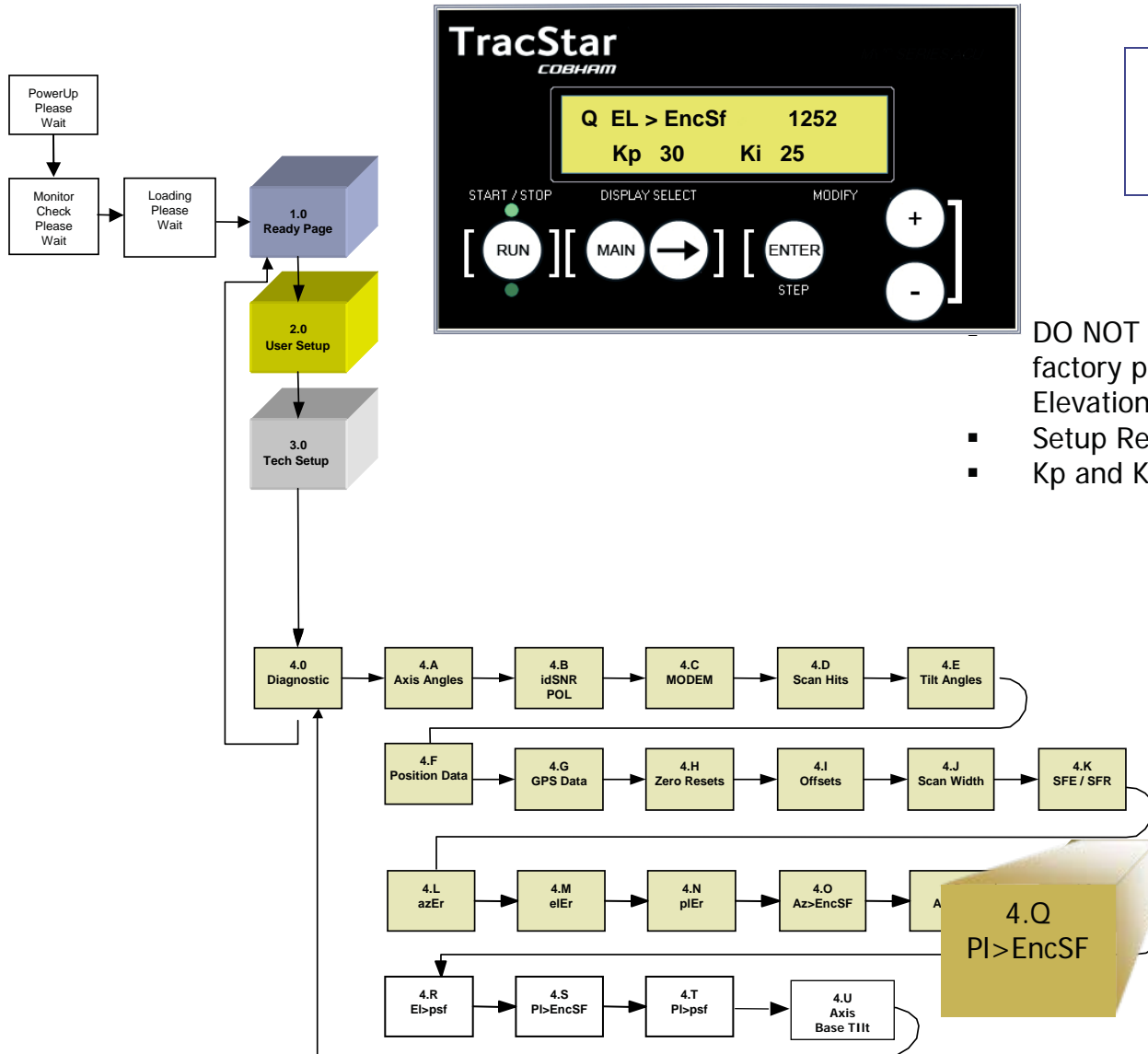

Q EL>EncSf	1252
Kp 30	Ki 25

DO NOT CHANGE without assistance from factory personnel

- Elevation Encode Scale Factor
- Setup Readings for Elevation Axis
- Kp and Ki are servo loop data

4.R Axis Diagnostics

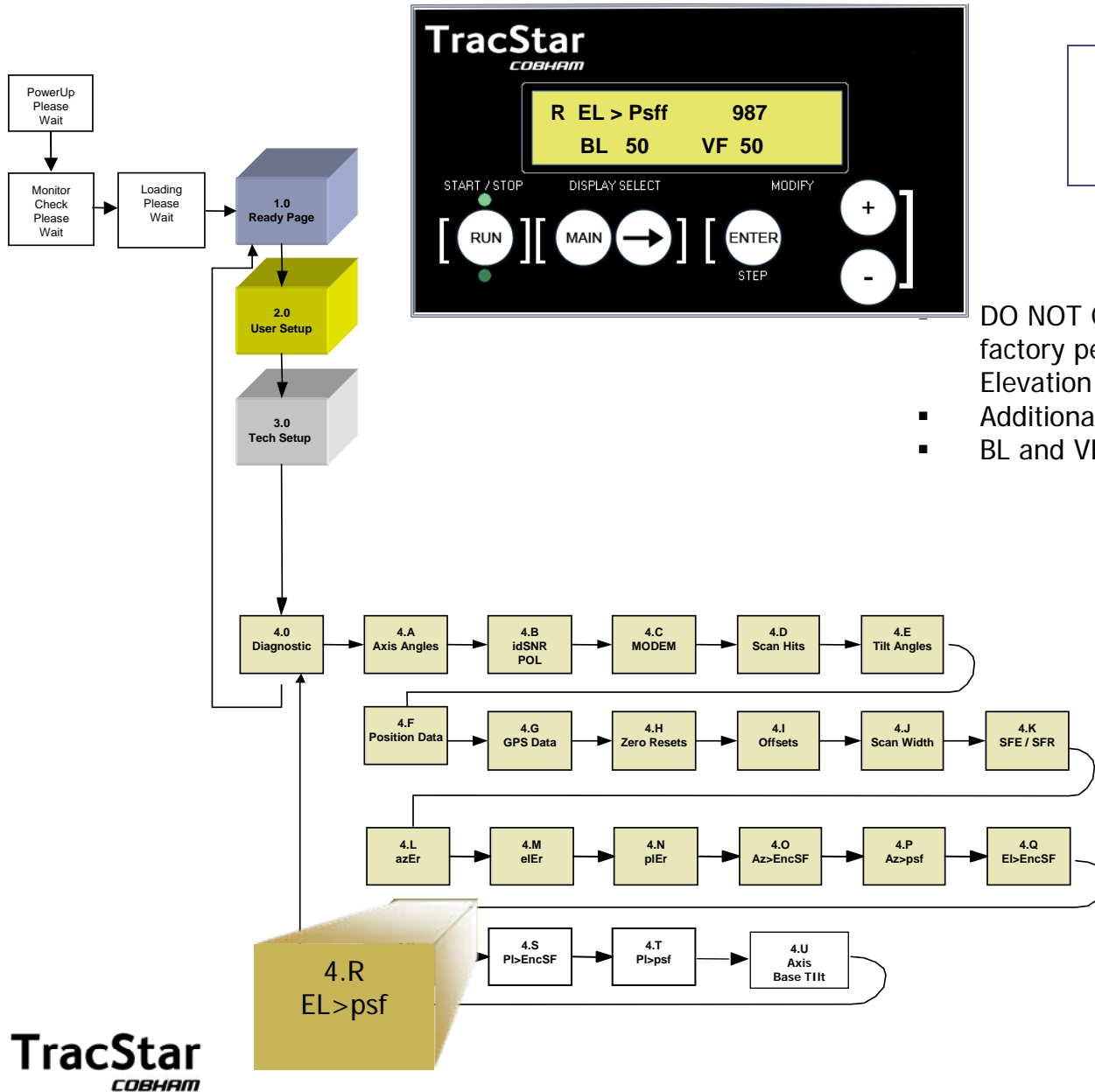

R EL>Psf	987
BL 50	VF 60

- DO NOT CHANGE without assistance from factory personnel
- Elevation Pot Scale Factor
 - Additional Setup Readings for elevation axis
 - BL and VF are servo parameters

4.S Axis Diagnostics

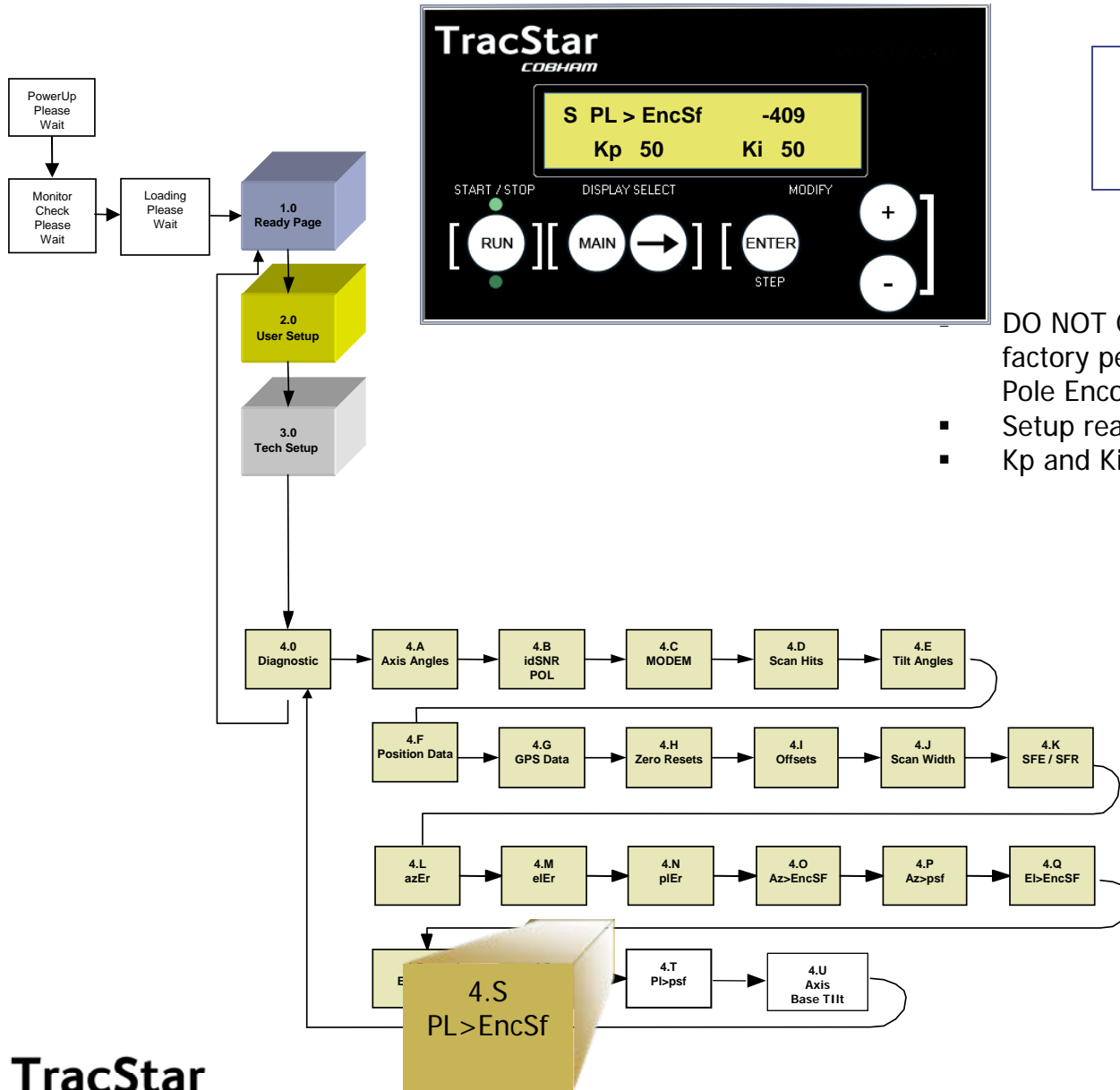

S PL>EncSf	-409
Kp 50	Ki 50

DO NOT CHANGE without assistance from factory personnel

- Pole Encode Scale Factor
- Setup readings for Pole axis
- Kp and Ki are servo loop data

4.T Axis Diagnostics

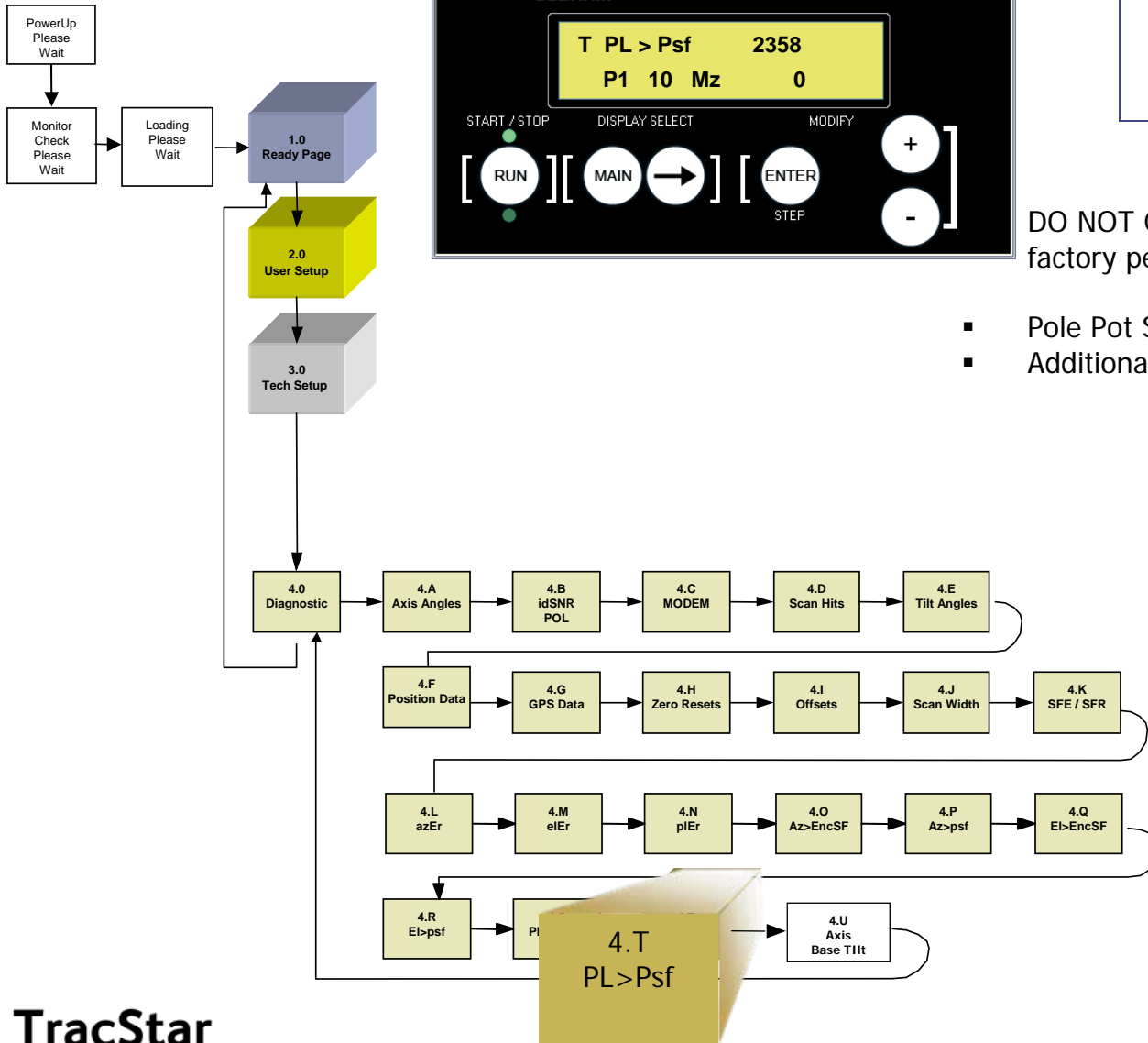

T	PL>Psf	2358	
P1	10	Mz	0

DO NOT CHANGE without assistance from factory personnel

- Pole Pot Scale Factor
- Additional setup readings for pole axis

4.U Axis Diagnostics

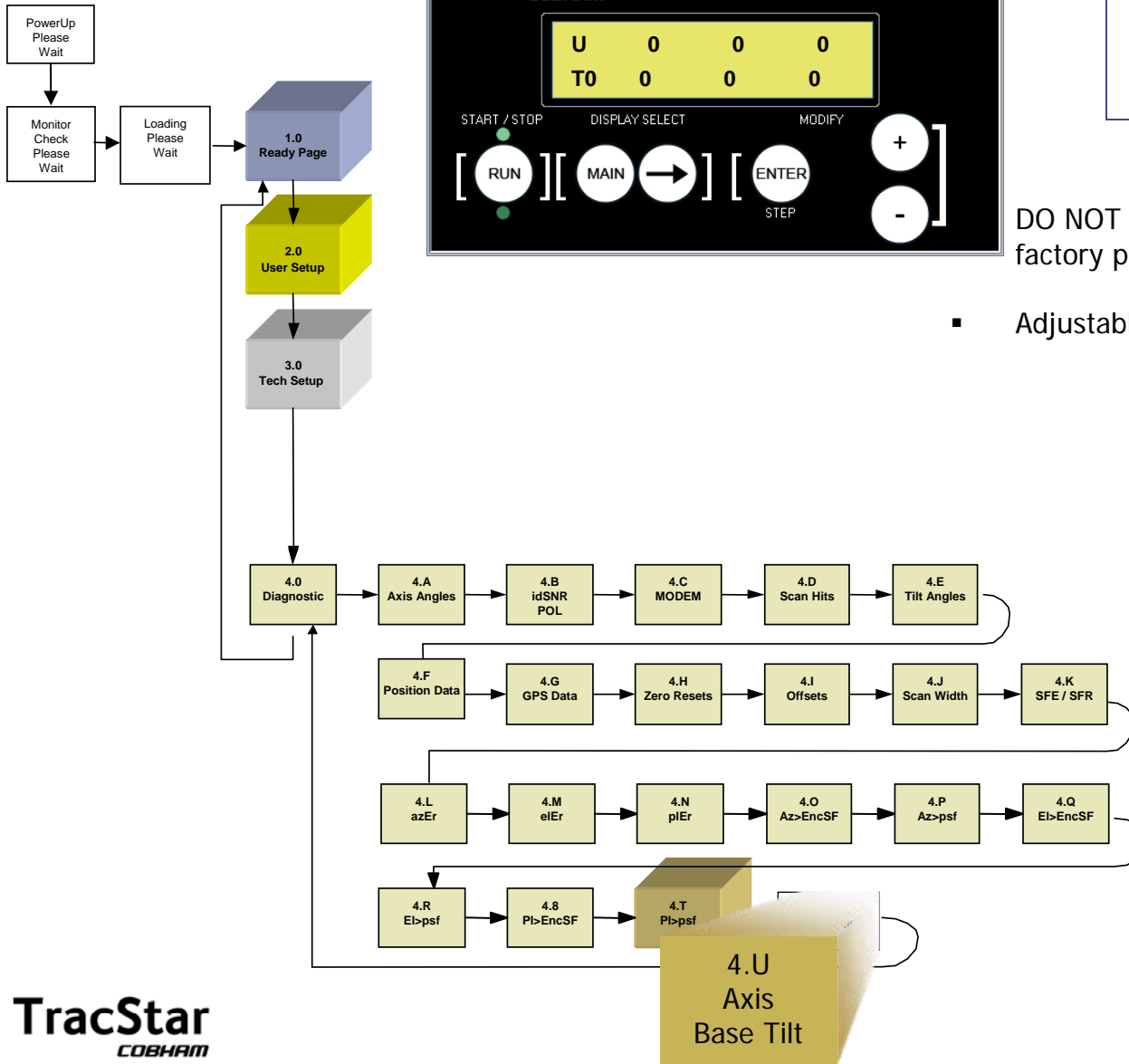

U	0	0	0
t0	0	0	0

DO NOT CHANGE without assistance from factory personnel

- Adjustable Base-Tilt threshold setting "T"

TROUBLESHOOTING

- **Antenna has no power.**
Turn off Power. Check the power cord on the ACU and or the rack mount control panel. The antenna receives its power from one of these two respective locations. Check pins 1 & 2 of the antenna end of the grey cable with the black connectors as well. Reapply Power. Restore Power.
- **OBSTRUCTIONS**
Ensure there is a clear unobstructed view towards the equator relative to the antenna's position.
- **Antenna Not Responding**
When using the handheld controller, ensure the RJ11 (phone cord) connection is properly seated in the ACU and the handheld device. Ensure all cables are securely connected.
- **Skyscan**
Skyscan can be engaged to find all available satellites in the sky. Refer to the operating manual for instruction on using Skyscan.
- **Waiting Log On (iDirect - NetModem or Infiniti Series)**
The TracStar controller 'logs' into the iDirect modem, when iDirect modem is selected. Make sure the DB9-RJ45 cable is in place between the controller and the modem, as this serves as the communication link. If communication still fails, set modem to NONE to allow antenna to lock onto satellite.

MINOR ERROR MESSAGES – FIELD REPAIRABLE

- COMPASS ERROR – Not seeing the compass, follow the manual compass procedure
- Stuck on GPS – Not detecting any GPS satellite – Follow the manual GPS procedure
- POWER UP PLEASE WAIT – No communications between the ACU and antenna. Check Interconnection cable from modem to antenna controller
- NO REF SAT FOUND – Antenna can't find a reference satellite. Verify the antenna has clear exposure to the southern sky
- NO XPONDER SIGNAL – Antenna can't find the data satellite. Verify the antenna has clear exposure to the southern sky
- BASE ANGLE LIMIT – Antenna base angle exceeds 8°. Level the antenna.
- BASE TILT ERROR – Antenna has moved after being deployed. Start a reacquisition
- SAT ERROR – No satellite information is programmed into the antenna. Reprogram satellite data.

MAJOR ERROR MESSAGES – POTENTIAL RECOVERY

- AZ MAJOR OT – Antenna has been driven beyond the azimuth electrical limit. Error may be recoverable by stowing several times.
- AZ OVER TRAVEL – Antenna has reached the electrical limit. Error may be recoverable by stowing several times.
- PL MAJOR OT – Antenna has been driven beyond the polarization electrical limit. Error may be recoverable by stowing several times.
- PL OVER TRAVEL – Antenna has reached the electrical limit. Error may be recoverable by stowing several times.
- EL OVER TRAVEL – Antenna has reached the electrical limit. Error may be recoverable by stowing several times.

MAJOR ERROR MESSAGES – FATAL ERRORS

Check antenna for movement blockage from trees, wifi masts, etc.

- POWER UP PLEASE WAIT – No communications between the ACU and the antenna.
 - a) circuit board failure b) control cable failure
- AZ FAULT – Not detecting any azimuth motor movement
 - a) Motor Failure b) circuit board failure
- PL FAULT – Not detecting any polarization motor movement
 - a) Motor Failure b) circuit board failure
- EL LOW LIMIT – Antenna is reporting low elevation fault
 - a) bad sensor b) improper jogging
- EL FAULT – Not detecting any elevation motor movement
 - a) Motor Failure b) circuit board failure

Possible Causes

Pedestal Preventative Maintenance

While the antenna pedestal is designed to be maintenance free, some common practices and scheduled preventative maintenance will help ensure your satellite antenna experience is safe and trouble free. Following the steps below will help ensure that your next deployment has no last-minute undiscovered problems that prevent operation. To paraphrase a SEALS phrase (the 6P's), "Proper Previous Planning Prevents Poor Performance."

After Each Use – check your antenna for physical damage from wind and / or trees and obstacles that may have been obstructing clearances, e.g., trees, buildings, power lines. Check for physical debris, lodged in the antenna mechanisms.

Monthly – Deploy the antenna. Check for:

- a) The word LOCK to appear in the TracStar ACU display window indicating it is locked onto a satellite
- b) The ability to reach the internet with your computer systems / onboard network
- c) Proper Operation of the primary VoIP channel for phone calls over the satellite link

Stow the antenna. Check for:

- a) The word STOW to appear in the TracStar ACU display window indicating it is securely stowed
- b) Physical damage
- c) Proper operation of 3rd party external STOW sensors (vehicle integrators / manufacturers)

Semi-Annually – Deploy the antenna. Check for:

- a) All monthly items
- b) Abnormal cable wear or corrosion due to exposure to harsh chemicals
- c) Abnormal cable wear due to excessively high salt content (coastal regions)
- d) Loose cable connections
- e) Loose hardware on the boom / feed assembly

General Check List

1. Any small chips on the reflector front surface should be cleaned, filled with aluminum-loaded car body filler, rubbed down, primed and touched in with two-pack polyurethane paint.
2. The feed horn should be checked for cracks or damage.

Azimuth:

3. Check for unusual noise in the azimuth bearing, azimuth gearbox, and azimuth motor
4. Run in azimuth and check for unusual noise in azimuth motor
5. Check position of azimuth drive cables on capstan at 0°# Az
6. Check drive cables for damage
7. Run both Az limits and observe cable tracking
8. Check for excessive backlash in gearbox
9. Inspect cable terminations
10. Inspect Az potentiometer

Elevation:

11. Check for unusual noise in elevation pivot bushings and elevation gearbox
12. Run in elevation and check for unusual noise in elevation motor
13. Run up to limit
14. Check tracking of elevation drive cables
15. Check drive cables for damage
16. Check for excessive backlash in gearbox

Polarization:

17. Check for unusual noise in polarization pivot bearings and polarization gearbox
18. Run in polarization and check for unusual noise in polarization motor

5: Description of System

TracStar750 / AvL Model 750 iMoVSAT three-axis positioner is used as an example. Note that fundamental operation of all Roto-Lok positioners are identical relative to vehicle mount design. Minor changes exist in Fly- Away systems relative to reflector removal, POL rotation/operation and the number of cases provided for the antenna system proper. Note also the .75M antenna is the only antenna provided by either company that does not have gas struts or stabilizer bars for positioning and stabilizing the antenna boom assembly.

General

The Model TracStar750 / iMoVSAT antenna system is an elevation over azimuth positioner featuring the simple, rugged Roto-Lok® drive system that produces very low backlash, high stiffness, and high reliability. It is driven by a low backlash gearbox with DC motors and all drive components are high-strength steel encased in lubricated-for-life housings, resulting in the most reliable, no-maintenance system with the minimum of weight. The reflector is a 75 cm equivalent Channel Master illuminated by a corrugated horn. The options for the placement of the transmitter vary depending upon the size: A 1 - 4 watt BUC can be installed on the feed boom.

RF System

The offset reflector/feed system produces co-polarization patterns that easily meet the FCC Section 25.209 requirements beyond 1.72 degrees in the transmit band and 1.95 degrees in the receive band. It is also fully compliant with the ITU Recommendation for international use.

Roto-Lok Drive System

The patented Roto-Lok drive system utilizes highly reliable aircraft control cables in a redundant configuration to achieve a lightweight, very stiff drive system with zero backlash. This high-tech performance is achieved using low-tech components - by simply wrapping the cable around the drive capstan several times before wrapping the larger drive drum. This method results in a minimum free-length of cable. The load cable on the main drum is exponentially reduced as it is wrapped around the drum. Therefore, the total elongation of the cable under load is minimized. The Roto-Lok system has up to 10 times less backlash than that of comparable gear systems. The cables are pre-tensioned and spring-loaded at the main drum attachment point, which eliminates backlash at installation and from any unexpected cable stretch in the future.

Secondary Drive System

The Az and El Roto-Loks are driven by a low backlash worm gear set with a 15:1 and 30:1 ratio respectively. The low backlash of the worm gear drive is reduced further by the Roto-Lok drive ratio. This results in a lash equivalent of only $.1^\circ$ in azimuth and $.2^\circ$ in elevation as seen by the reflector system. The gear sets are encased in a sealed housing allowing for continuous lubrication in synthetic oil, maximizing gear efficiency and minimizing wear.

Motor Drives

Lightweight, reliable, servo-quality DC motors with integral gearbox are used for Az, El, and Pol drives. The motors are also equipped with optical encoders that provide precise speed and positioning control, ensuring smooth operation when peaking the antenna. The 24V DC design provides current-limiting torque control and will allow for vehicle battery operation if necessary.

Controls

The antenna control system is produced by TracStar Systems and is integrated exclusively with the Roto-Lok pedestal assembly. The controller includes a tunable receiver, GPS system, and flux-gate compass. The main portion of the controller is located on the antenna positioner, placing it close to the optical encoders. The power supply and hand-held controller are separate and can be placed up to 25 feet away without special hardware. Special control cables can be obtained to place the power supply and hand-held up to 150 feet away from the antenna.

The TracStar controller was developed to achieve one-button, auto-acquisition of the satellite signal 100% of the time using a proprietary method. The controller peaks the antenna on the data satellite with greater accuracy than a human can achieve, thus assuring that there is no chance of adjacent satellite interference. Primary and secondary reference satellite menus and data satellite menus are available for an untrained operator. Any data satellite can be selected or pre-programmed by a trained operator. Semi-automatic modes are available in case of failure of GPS or a flux-gate to provide acceptable manual input of case heading and/or latitude and longitude. An *Auto-Select* mode is the default factory setting for reference satellite selection in the TracStar software (domestic CONUS use only). The TracStar control system will work on any Ku Band satellite. Many antennas have options for C or Ka band solutions.

Construction

Except for the drive components and bearings, all components are aluminum, stainless steel or plastic to prevent rusting.

¹ Roto-Lok is a registered trademark of Sagebrush Technologies, Inc. All Rights Reserved.

6: General Deploy and Assembly Instructions

The TracStar TracStar750 / AvL Model 750 positioner has been fully tested with the TracStar controller prior to shipment. All position feedback, limit sensing, limit switches, and motor speeds have been calibrated or set. The positioner needs only to be deployed and the coax and control cables connected to the controller.

- 1. Model 750 shown in stowed position (Figure 1)

Figure 1

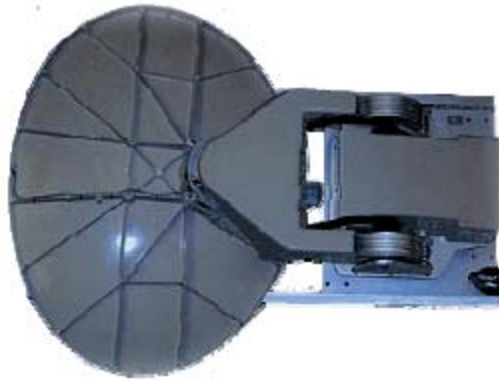

- 2. Connecting the coax cable first, make the appropriate electrical connections. (Figure 2.)

Figure 2



3. Press “+” on TracStar hand-held controller (Figure 4) and hold for 3 seconds until unit begins deploying.
4. Figure 3 shows the unit fully deployed.

Figure 3

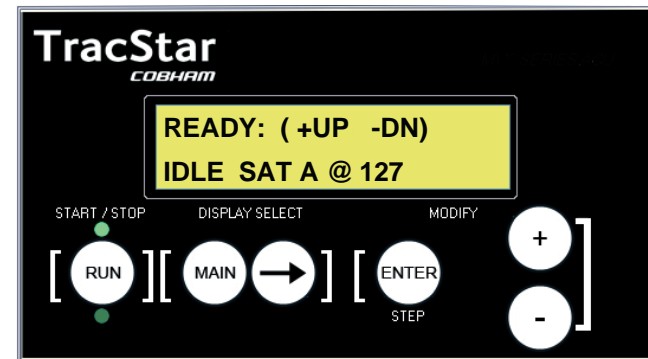

Controller Operating Instructions

1. To activate system, turn on power to the TracStar Indoor Unit (IDU). The display should read "Ready".
2. Press the "+" key to begin satellite acquisition.
3. To stow the antenna, press and hold the "-" key for 3 seconds. To insure that transmit is disabled, there is a 3-second delay before the antenna begins to stow.
4. The user may stop the motion by pressing the Start/Stop, + or - key at any time, either during an acquisition (Display reads "Run") while locked or during a stowing operation (Display reads "Stow").

Complete operating instructions can be found in the TracStar Controller Operating Instructions included in this manuals Index.

7: Azimuth Positioning System

Azimuth Bearing

The azimuth platform sits on top of a ball bearing platform with a dynamic and static moment capacity of over four times the worst-case wind-load specification. The assembly is surrounded by a double seal to protect the bearing platform, which is permanently lubricated. This rests on the azimuth drum and the azimuth cables wrap around the drum and capstan. Because of the excess capacity, low rpm and low number of cycles compared to the bearings B10 design life, no wear is expected. No maintenance should be required over the life of the positioner.

Azimuth Gearbox

The azimuth gearbox is a low backlash worm gearbox. The worm gear drive isolates any backlash in the motor drive from the system. In addition, since it is a 15:1 ratio, it will not back drive, thus eliminating any need for a brake on the drive train. The motor drives the input worm via a quill/female hole and square key. The azimuth capstan is secured to the bore of the output shaft with a square key. The gearbox contains synthetic oil. Because of the design capacity of the gearbox, low rpm and comparative limited cycles experienced by the system, no wear or maintenance is expected.

Azimuth Motor

The azimuth drive motor is a servo quality 24DC motor with an integral 19.7:1 spur gear train. The motor armature rotates at up to 4000 rpm causing a high-frequency noise that will vary, depending on the loading condition of the motor. An optical encoder is mounted to the other end of the motor output shaft to provide real-time positional information to the TracStar controller. The maximum gearbox output speed is 253 rpm. The output shaft is "D" shaped with a special adapter with a slot for a square key. Since the low backlash worm gear drive isolates the backlash from the motor, any backlash between the shaft adapter, square key, or motor gear train will never be seen by the reflector boresight. Any backlash at any of these points is of no consequence to the system performance. No maintenance or wear of the elevation motor is expected.

Azimuth Roto-Lok Cable Drive

The patented azimuth Roto-Lok drive produces a drive system with zero backlash, high stiffness, no wear, no lubrication, and maximum reliability. The system consists of three 1/16 9x17 stainless steel aircraft control cables, reverse-wrapped twice around the capstan with solid connections on one end and high force, Belleville springs on the other end occurring at the azimuth spring block. One cable has the capacity to withstand an 80 mph wind load. The additional cables are used to

provide increased stiffness and drive redundancy. ***If a cable becomes damaged during usage, merely cut off the cable and continue to use the positioner. You can replace the cable at your maintenance facility whenever time permits.***

The cables are sized to last the life of the positioner. No replacement from wear is expected. The spring package at one end will automatically compensate for any elongation of the cable. At installation, the Belleville springs are collapsed until no "air" is seen between the springs. You should check this condition yearly to account for the slow settling of the cable strands. Use a 3/8 box-end wrench to tighten the nut. ***Be sure not to over tighten.***

Azimuth Position Feedback

The azimuth position feedback is produced by a 10-turn, 1K-ohm potentiometer driven by the output shaft of the worm gearbox. In addition, an optical encoder is mounted to the output shaft on the motor and provides redundant feedback on azimuth position. The encoder also provides precise redundant feedback on unit's position relative to zero degrees starting position. The potentiometer is mounted on an angle plate that is mounted to the azimuth gearbox. A gear mounted to the potentiometer is driven by a pinion on the output shaft of the gearbox. The potentiometer is mechanically set at the one-half travel position when the azimuth cable position is at zero degrees. The azimuth stow switch is a magnetic proximity switch mounted in the az platform. The limits are controlled by using inputs from the potentiometer and optical encoder together and are set in and controlled by the TracStar controller. The azimuth drive has the mechanical capability of $\pm 400^\circ$ or $\pm 200^\circ$ from stow position.

8: Elevation Positioning System

Elevation Pivot Assembly

The elevation pivot assembly consists of two elevation drum assemblies pivoting between two clevis blades that house the high-tech, no-lubrication required, plastic bushings. No wear or maintenance is expected.

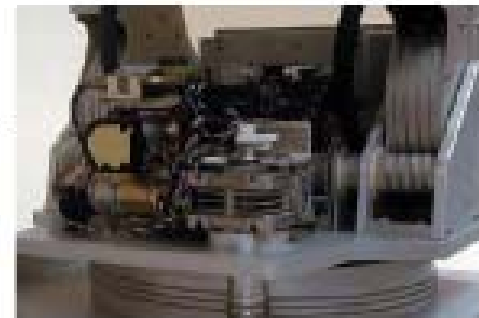

Elevation Gearbox

The elevation gearbox is a low backlash worm gearbox. The worm gear drive isolates any backlash in the motor drive from the system. In addition, since it is a 30:1 ratio, it will not back drive eliminating any need for a brake on the drive train. The motor drives the input worm via a quill/female hole and square key. The dual elevation drive shafts are driven with a square key. The elevation capstan is secured to the dual output shafts with a cap screw that clamps to the output shaft. The gearbox contains synthetic oil. Because of the design capacity of the gearbox, low rpm and comparative limited cycles experienced by the system, no wear or maintenance is expected.

Elevation Motor

The elevation drive motor is a 24V DC motor with integral spur gear train. The motor armature rotates at up to 4000 rpm causing a high frequency noise that will vary depending on the loading condition of the motor. An optical encoder is mounted to the other end of the motor output shaft to provide real time positional information to the TracStar controller. The maximum output speed is 133 rpm. The output shaft is a standard keyed shaft. The output torque capacity of the motor is rated for the operational wind load. Since the low backlash worm gear drive isolates the backlash from the motor, any backlash between the square key and motor gear train will never be seen by the reflector boresight. Any backlash at any of these points is of no consequence to the system performance. No maintenance or wear of the elevation motor is expected.

Elevation Roto-Lok Cable Drive

The patented azimuth Roto-Lok drive produces a drive system with zero backlash, high stiffness, no wear, no lubrication, and maximum reliability. The system consists of eight 1/16 9x17 stainless steel aircraft control cables, reverse-wrapped three times around the capstan with solid connections on one end and high force, Belleville springs on the other end occurring at the elevation cable termination block.

Four cables have the capacity to withstand an 80 mph wind load. The additional cables are used to provide increased stiffness and drive redundancy. ***If a cable becomes damaged during usage, merely cut off the cable and continue to use the positioner. You can replace the cable at your maintenance facility whenever time permits.***

The cables are sized to last the life of the positioner. No replacement from wear is expected. The springs package at one end will automatically compensate for any elongation of the cable. At installation, the Belleville springs are collapsed until no "air" is seen between the springs. You should check this condition yearly to monitor the slow settling of the cable strands.

Elevation Position Feedback

The elevation position feedback is produced by an electronic clinometer and encoder mounted on the output shaft of the motor. The clinometer has a resolution of 0.1 degrees with the accuracy/linearity of 1% of the 0-45° range and monotonic in the 45-90° range. The clinometer is rated for an outdoor environment. The encoder also provides precise feedback on the unit's position during operation. The limits are controlled by using inputs from the clinometer and optical encoder together and are set in and controlled by the TracStar controller. The clinometer is mounted on a bracket under the pol gear cover. The clinometer is covered with an aluminum cover to protect it from the mechanical damage and provide additional weather protection.

9: Polarization Feed and Drive Assembly

General

The feed assembly consists of the feed boom, feed housing, RF components and polarization drive. The feed boom is pivoted at the bottom of the reflector. The feed assembly is mounted to the feed boom.

Polarization Drive

The polarization drive motor is a 24DC gear motor. It is attached to the polarization gearbox. Polarization setting is accomplished by rotation of the reflector.

Polarization Gearbox

The azimuth gearbox is a worm gearbox. The worm gear drive isolates any backlash in the motor drive from the system. In addition, since it is a 30:1 ratio, it will not back drive, thus eliminating any need for a brake on the drive train. The gearbox contains synthetic oil. Because of the design capacity of the gearbox, low rpm, and comparative limited cycles experienced by the system, no wear or maintenance is expected.

Polarization Roto-Lok Cable Drive

The patented azimuth Roto-Lok drive produces a drive system with zero backlash, high stiffness, no wear, no lubrication, and maximum reliability. The system consists of two 1/16 9x17 stainless steel aircraft control cables, reverse-wrapped twice around the capstan with solid connections on one end and high force, Belleville springs on the other end occurring at the polarization spring block. One cable has the capacity to withstand an 80 mph wind load.

The additional cables are used to provide increased stiffness and drive redundancy. ***If a cable becomes damaged during usage, merely cut off the cable and continue to use the positioner. You can replace the cable at your maintenance facility whenever time permits.***

The cables are sized to last the life of the positioner. No replacement from wear is expected. The springs package at one end will automatically compensate for any elongation of the cable. At installation, the Belleville springs are collapsed until no "air" is seen between the springs. You should check this condition yearly to monitor the slow settling of the cable strands.

Polarization Position Feedback

The polarization position feedback is produced by the optical encoder mounted on the output shaft on the motor. The polarization stow and limit switch is mounted under the polarization platform and is accessible under the pol cover. The switch is fixed to a plate and is actuated by a rotation cam. The limits are controlled by using inputs from switches and optical encoder together and are set in and controlled by the TracStar controller. Pol stow is achieved by activating the stow switch mounted on the polarization cam. The polarization drive has the mechanical capability of $\pm 75^\circ$ or $\pm 95^\circ$.



10: Preventative Maintenance

General

The TracStar TracStar750 / AvL Model 750 iMoVSAT is constructed to require a minimum amount of regular maintenance.

The following 21-Point Check List should be undertaken on a regular basis and can be rectified in the field:

21 Point Check List

1. Any small chips on the reflector front surface should be cleaned, filled with aluminum-loaded car body filler, rubbed down, primed and touched in with two-pack polyurethane paint.
2. The feed horn should be checked for cracks or damage.

Azimuth:

3. Check for unusual noise in the azimuth bearing, azimuth gearbox, and azimuth motor
4. Run in azimuth and check for unusual noise in azimuth motor
5. Check position of azimuth drive cables on capstan at 0°# Az
6. Check drive cables for damage
7. Run both Az limits and observe cable tracking
8. Check for excessive backlash in gearbox
9. Inspect cable terminations
10. Inspect Az potentiometer

Elevation:

11. Check for unusual noise in elevation pivot bushings and elevation gearbox
12. Run in elevation and check for unusual noise in elevation motor
13. Run up to limit
14. Check tracking of elevation drive cables
15. Check drive cables for damage
16. Check for excessive backlash in gearbox

Polarization:

17. Check for unusual noise in polarization pivot bearings and polarization gearbox
18. Run in polarization and check for unusual noise in polarization motor

- 19. Check tracking of polarization drive cables
- 20. Check drive cables for damage
- 21. Check for excessive backlash in gearbox

Spare/Replacement Parts

Since no wear or maintenance is expected, only electrical parts are recommended as spares. These parts will not fail from activity, but may fail from environmental exposure.

Optional:

Description	Manufacturer	Manufacturer's Part #
Limit Switch Omron		D2VW-5L2A-1HS
Potentiometer, 1k, 10T		Spectrol 01F8239
Proximity Switch		CDI PS811
Clinometer		Spectron 02110002-000
Spare Drive Cable Kit	AvL Technologies	
Elevation Motor	Pittman	GM9234E521
Azimuth Motor	Pittman	GM9236E522
Polarization Motor	Pittman	GM8724J199-R1

Modem and Voice Equipment Connection / Wiring Diagrams

NOTE: For VoIP follow EMS with TracStar Gateway or System Integration connection information for the general sense of connecting the Gateway to voice devices.

The TracStar gateway serves as:

- Router / DHCP Server

- Firewall

- Gateway

- WAN (4 Ports)

- LAN (4 Ports)

- QoS Manager for voice products (Quality of Service)

- FXS / FXO Portal (8 Ports total, Blocks of 4 FXS or FXO)

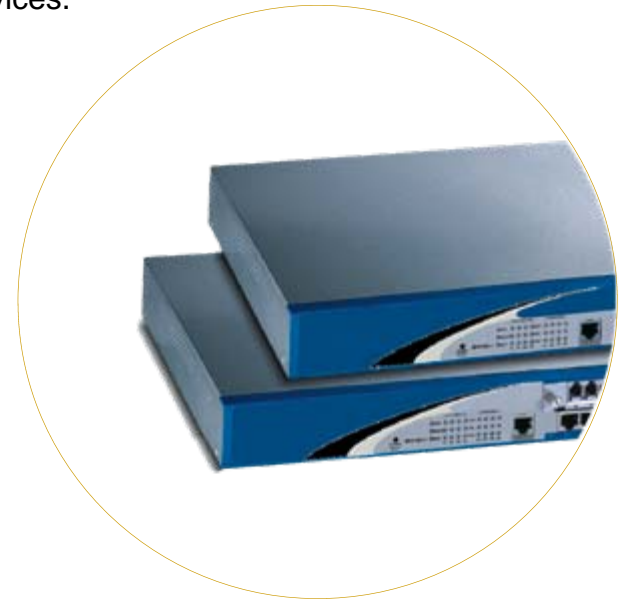

External Stow Monitoring – Vehicle Mounting



Figure A



Figure B

Every month, TracStar receives tech support calls due to antennas striking an immobile object while the antenna is deployed and a vehicle is moving. There is little an OEM can do to absolutely prevent the occurrence, as the onus is on the operator of the vehicle to safely maneuver same.

Refer to Section 3.5 in the manual – Move/RF_SAFE. This feature is DISABLED by factory default. Enabling Move/RF_SAFE may help, but still can't guarantee safe operation (see Section 3.5) if procedures are not followed.

There are multiple methods of using external stow sensing to assist in safely securing the antenna prior to moving a vehicle. The 1.2 Meter antenna has a switch located in the stow bumper and the wiring for the switch is secured to the IFL cable bulkhead on the antenna pedestal, as shown in Figure A. This switch can be wired to a user provided SPST relay circuit that would provide power to an illumination device in the cab of the vehicle indicating the antenna is still deployed. Alternately, the circuit could lockout the ignition or prevent the transmission from engaging while the antenna is deployed.

Alternately, an external stow switch, Figure B, could be engaged to assist in safely sensing the antenna is stowed prior to moving a vehicle, and used in the same manor as previously mentioned.

TracStar assumes no liability or responsibility for physical damage to antennas, or from loss of service or operation due to physical damage incurred while the antenna is deployed.

Connexstar
Gilat 360E

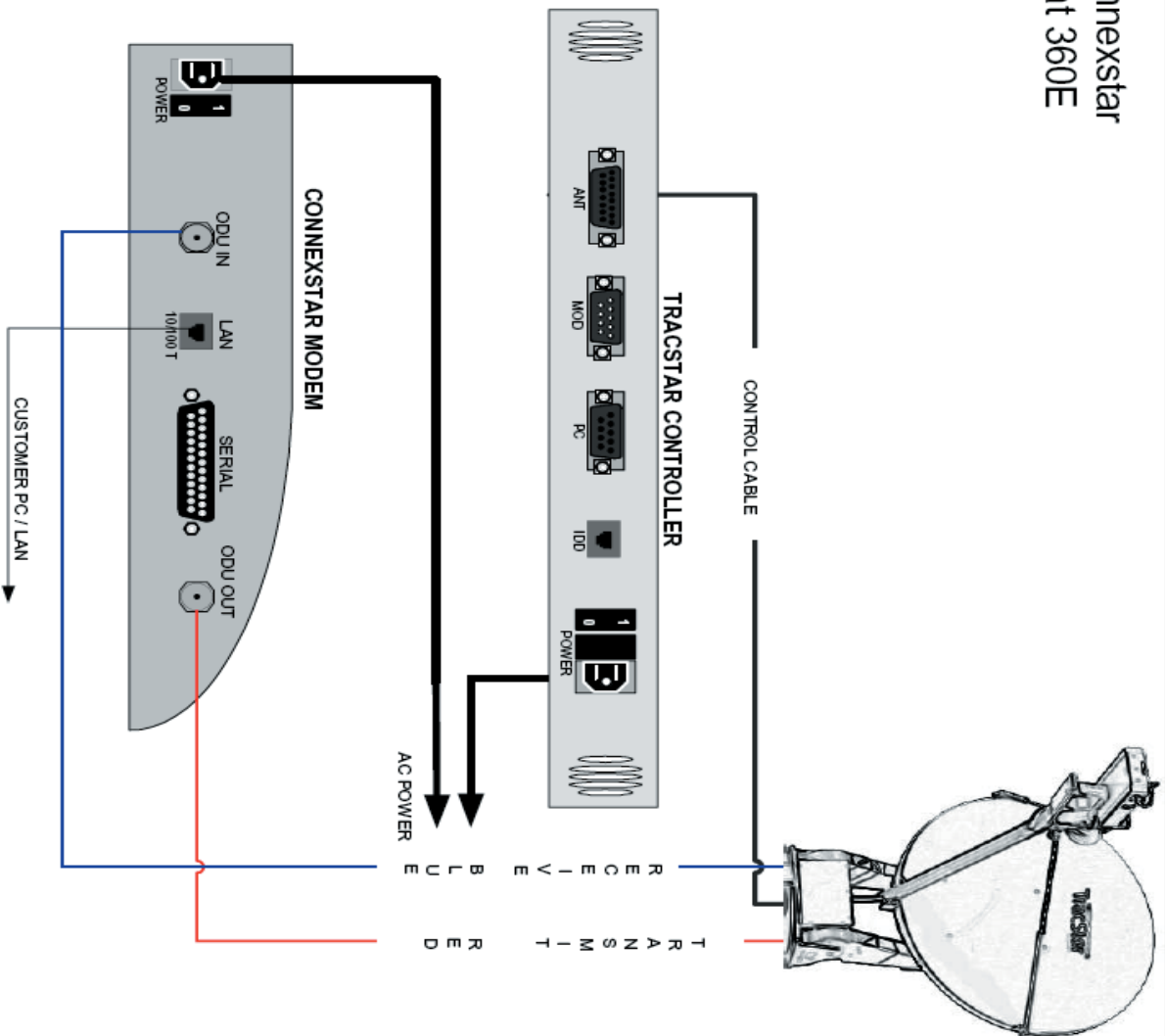

The RG-6 cables employ a two piece connection which allow the O-Ring in the smaller nut to seal when placed on the F-Type connector. Once the cable is connected, the smaller nut is tightened against the cable end allowing the O-ring to provide a moisture proof seal.

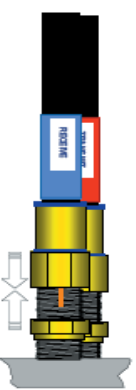

BASIC SYSTEM CONFIGURATION
CONNEXSTAR MODEM (DESK TOP)

TracStar Systems, Inc.

Friday, March 03, 2006

SkyEdge Modem

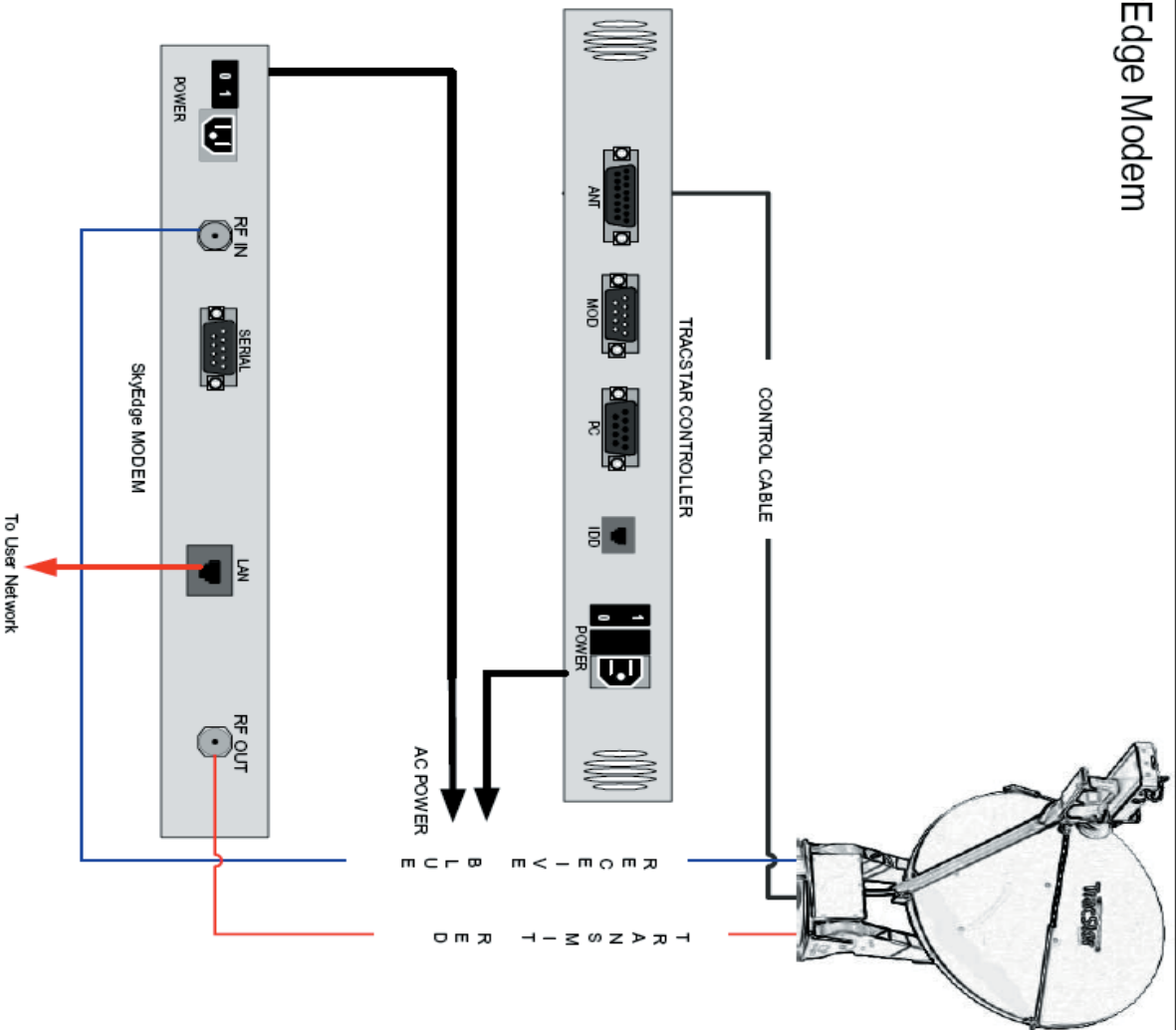

The RG-6 cables employ a two piece connection which allow the O-Ring in the smaller nut to seal when placed on the F-Type connector. Once the cable is connected, the smaller nut is tightened against the cable end allowing the O-ring to provide a moisture proof seal.

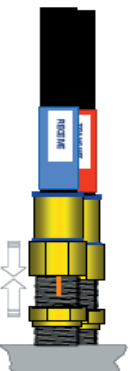

BASIC SYSTEM CONFIGURATION
SkyEdge Modem (Non - RACK MOUNT)

TracStar Systems, Inc.

Friday, March 03, 2006

Connexstar / Cisco Bruno Module

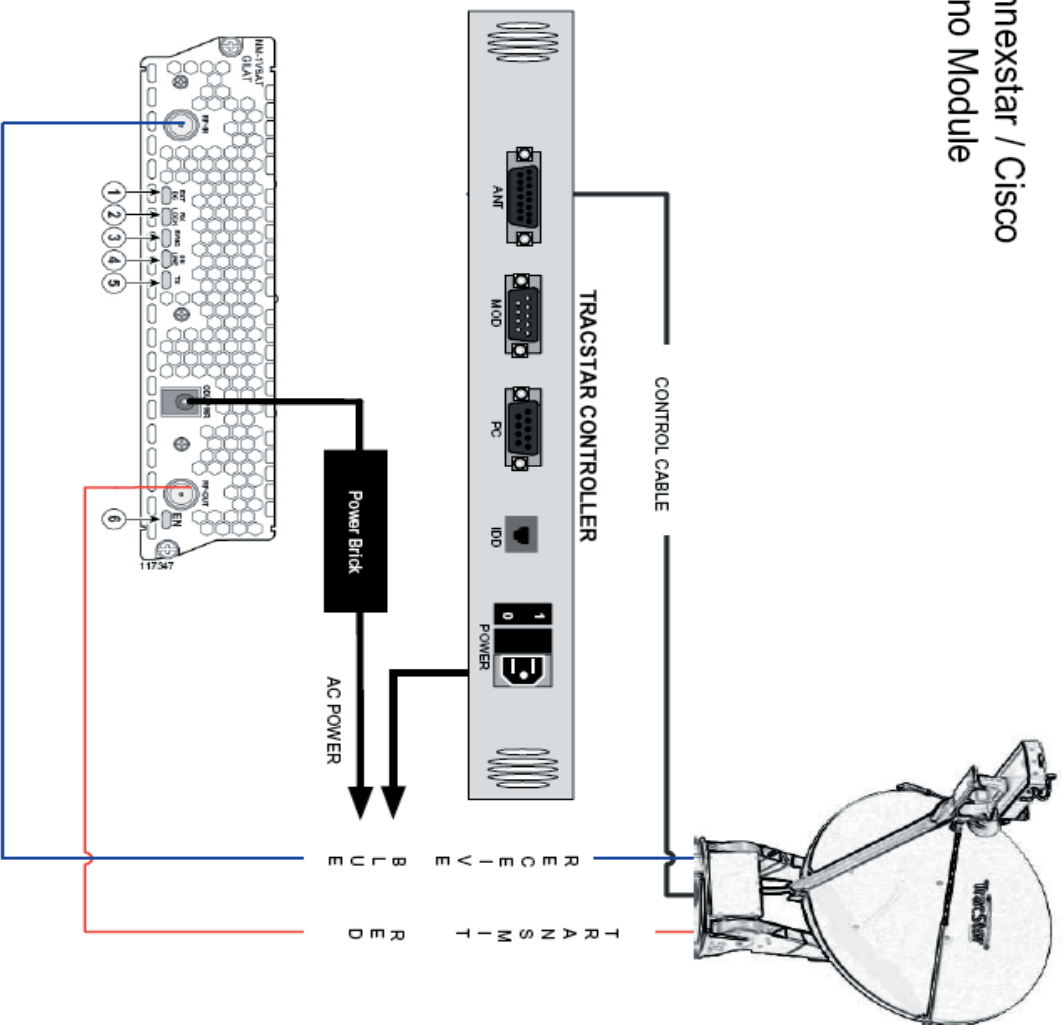

The RG-6 cables employ a two piece connection which allow the O-Ringin the smaller nut to seal when placed on the F-1 type connector. Once the cable is connected, the smaller nut is tightened against the cable and allowing the O-ring to provide moisture proof seal.

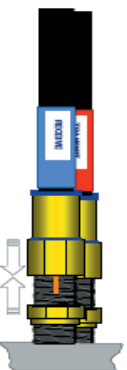

BASIC SYSTEM CONFIGURATION
CONNEXSTAR MODEM (DESKTOP)

TracStar Systems, Inc.

Tuesday, March 07, 2006

EMS Technologies Connections

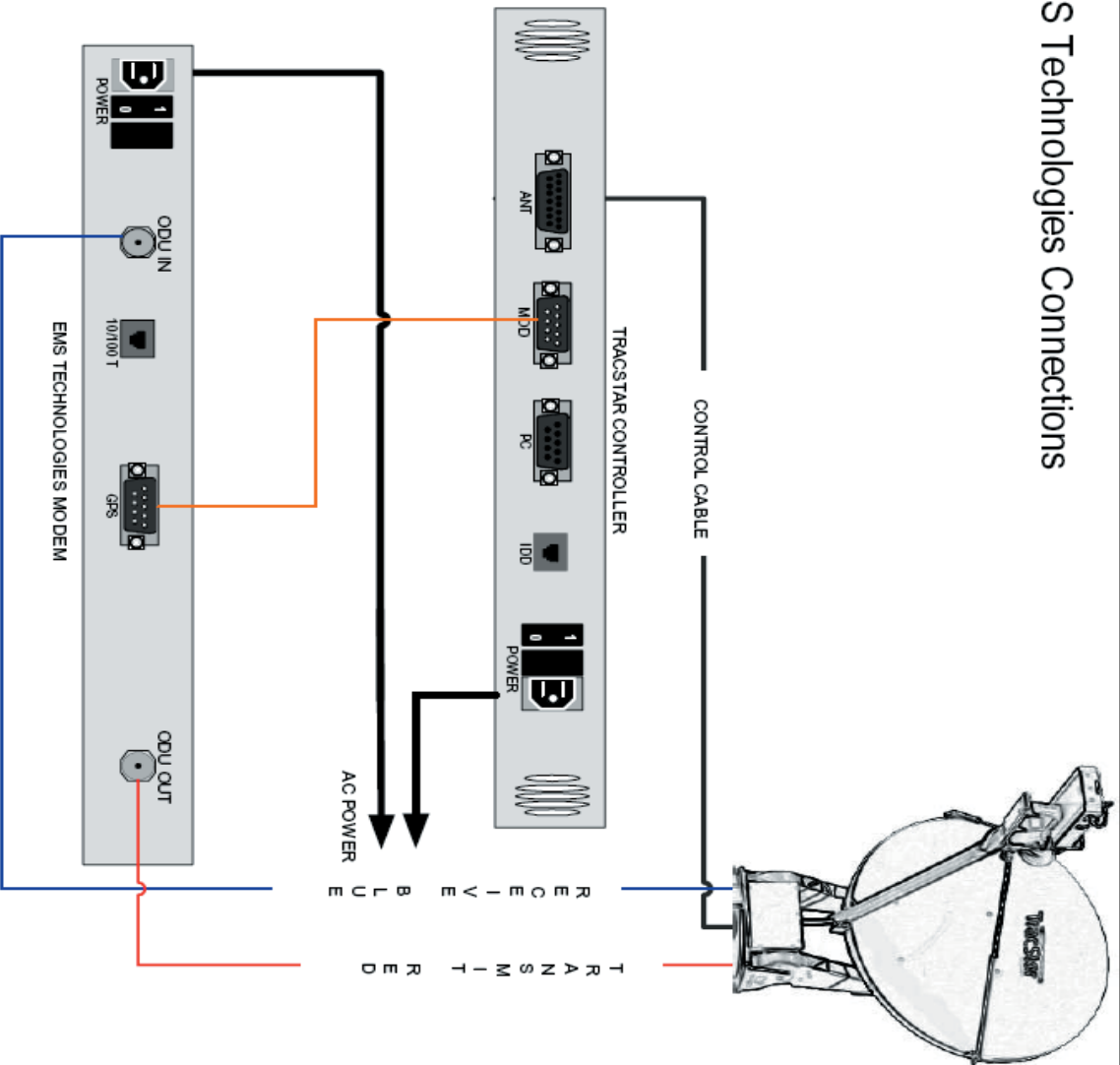

The RG-6 cables employ a two piece connection which allow the O-Ring in the smaller nut to seal when placed on the F-Type connector. Once the cable is connected, the smaller nut is tightened against the cable end allowing the O-ring to provide a moisture proof seal.

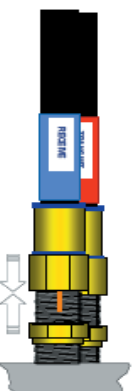

BASIC SYSTEM CONFIGURATION
EMS TECHNOLOGIES MODEM (RACK MOUNT)

TracStar Systems, Inc.

Thursday, March 17, 2005

EMS with EdgeAccess Connection

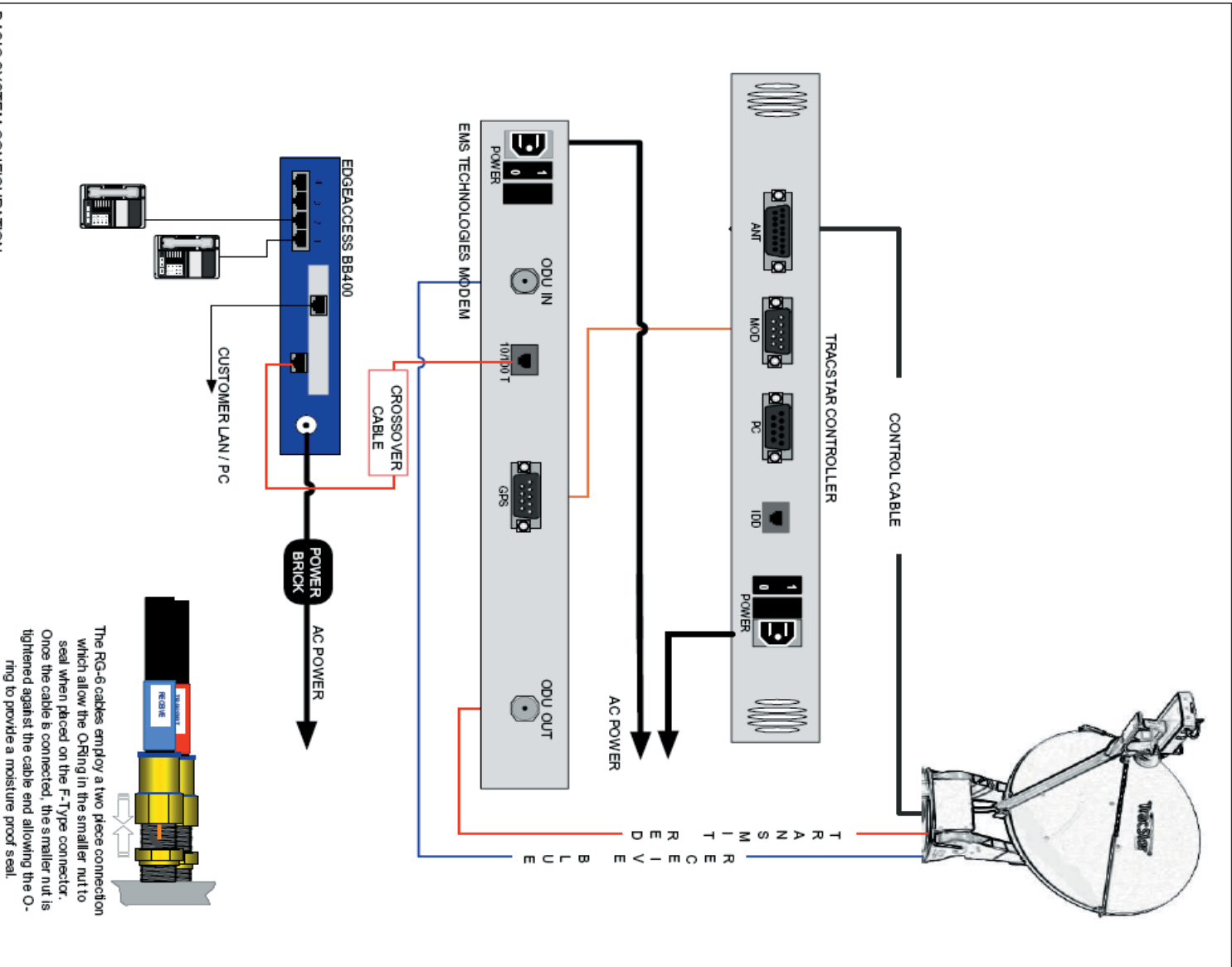

BASIC SYSTEM CONFIGURATION
 EMS TECHNOLOGIES MODEM
 EDGEACCESS VOIP EQUIPMENT

TracStar Systems, Inc.

Thursday, March 17, 2005

iDIRECT Netmodem II / Plus

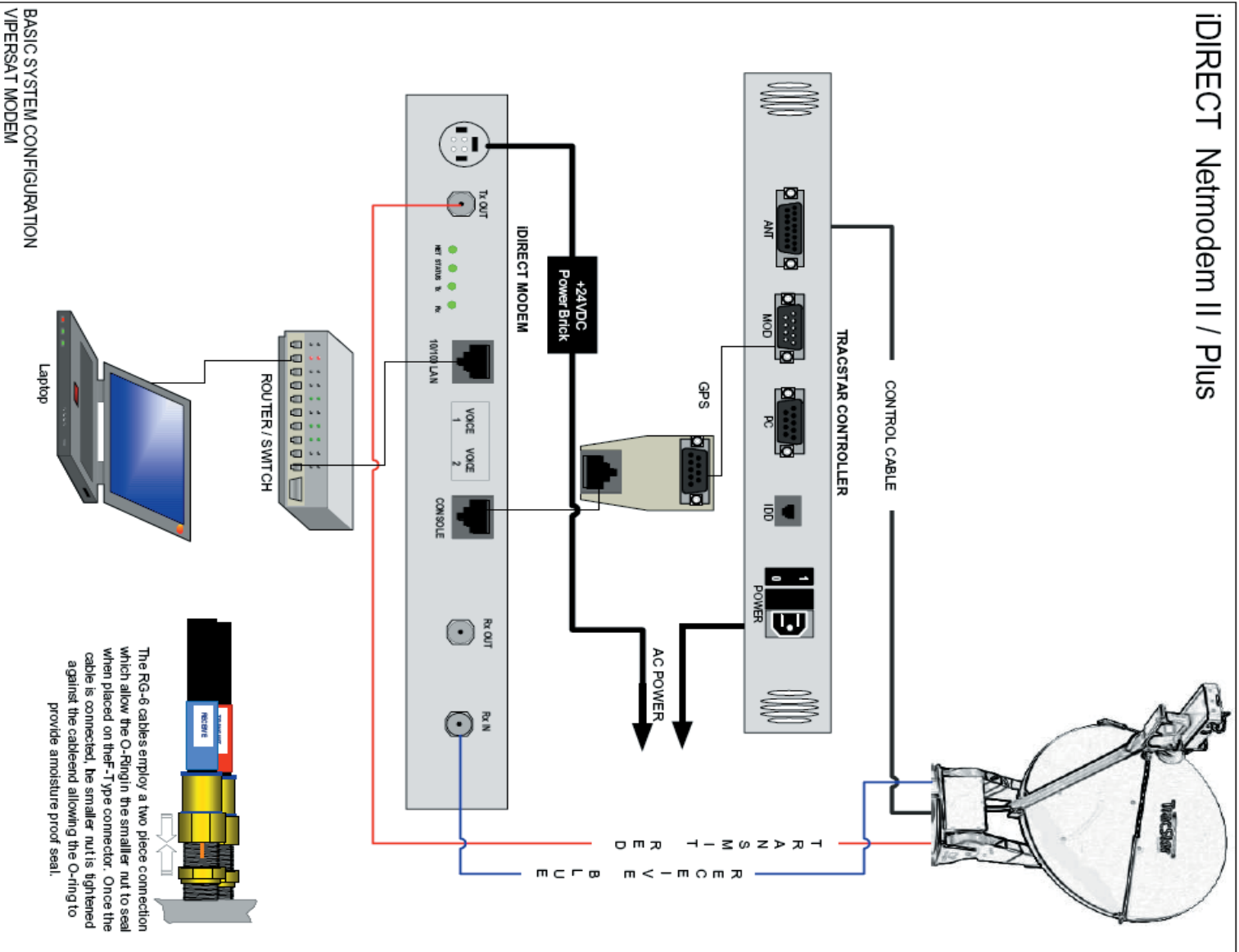

BASIC SYSTEM CONFIGURATION
VIPERSAT MODEM

TracStar Systems, Inc.

Friday, March 03, 2006

Avaya G350 Switch Connection

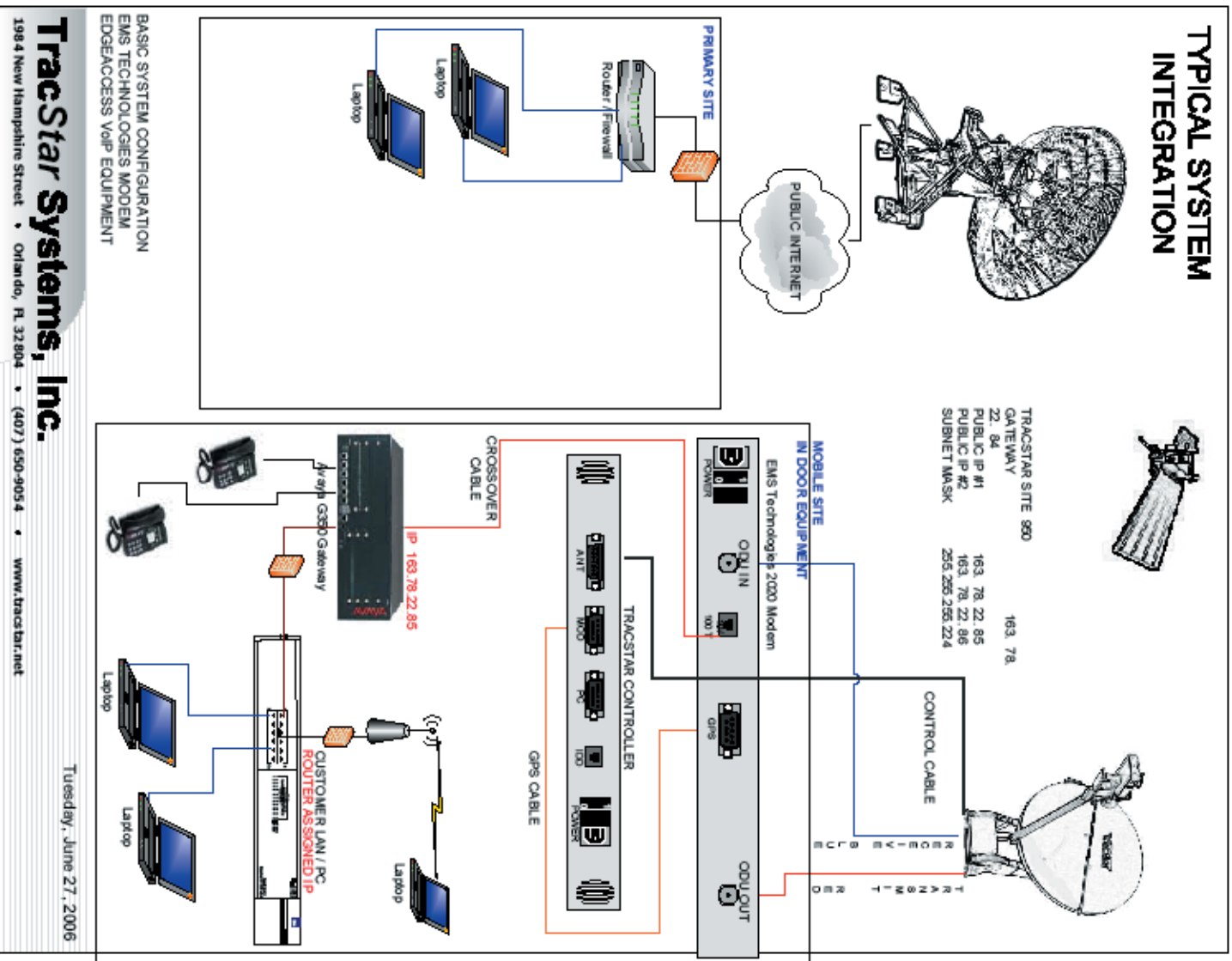

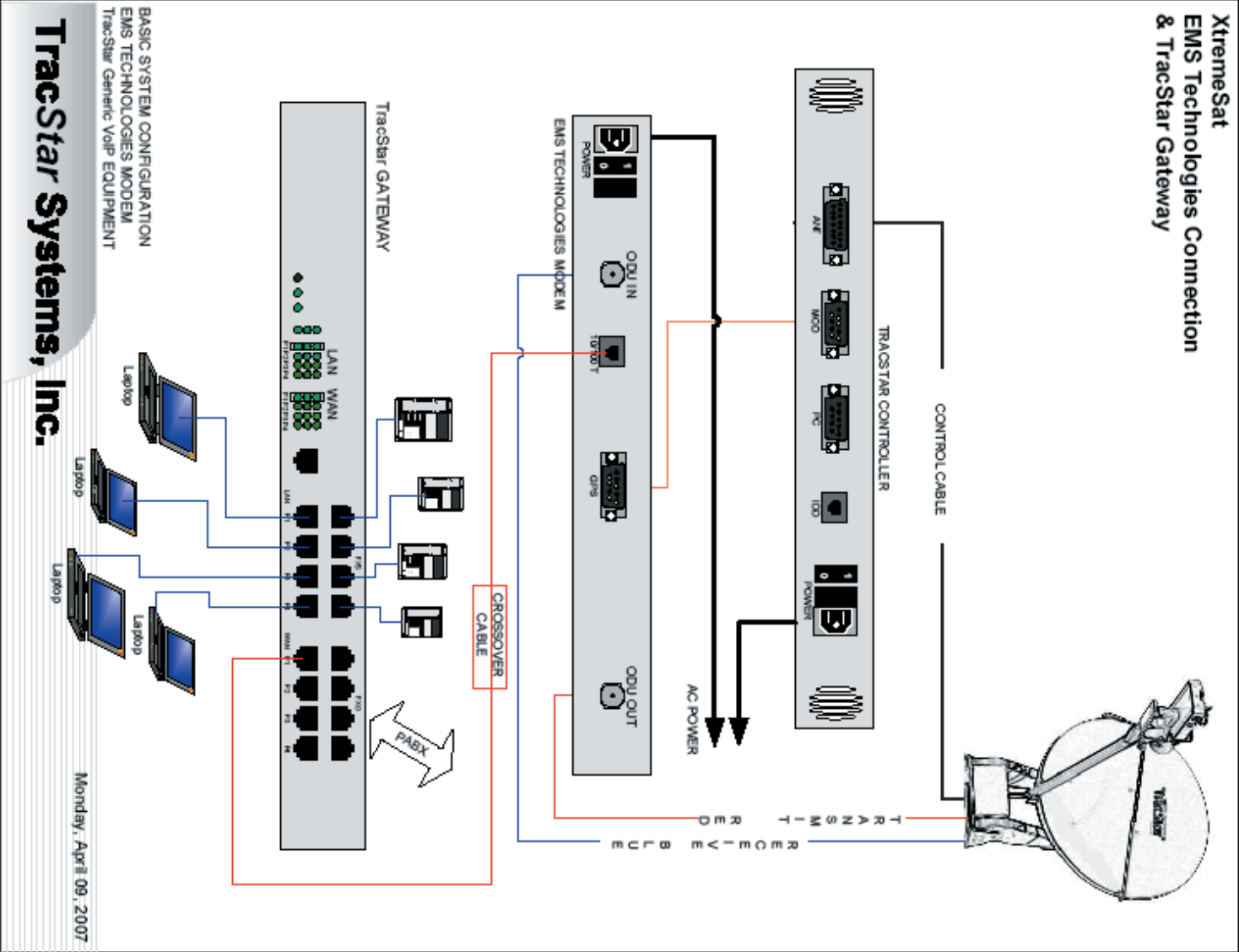

iDIRECT Netmodem II / Plus

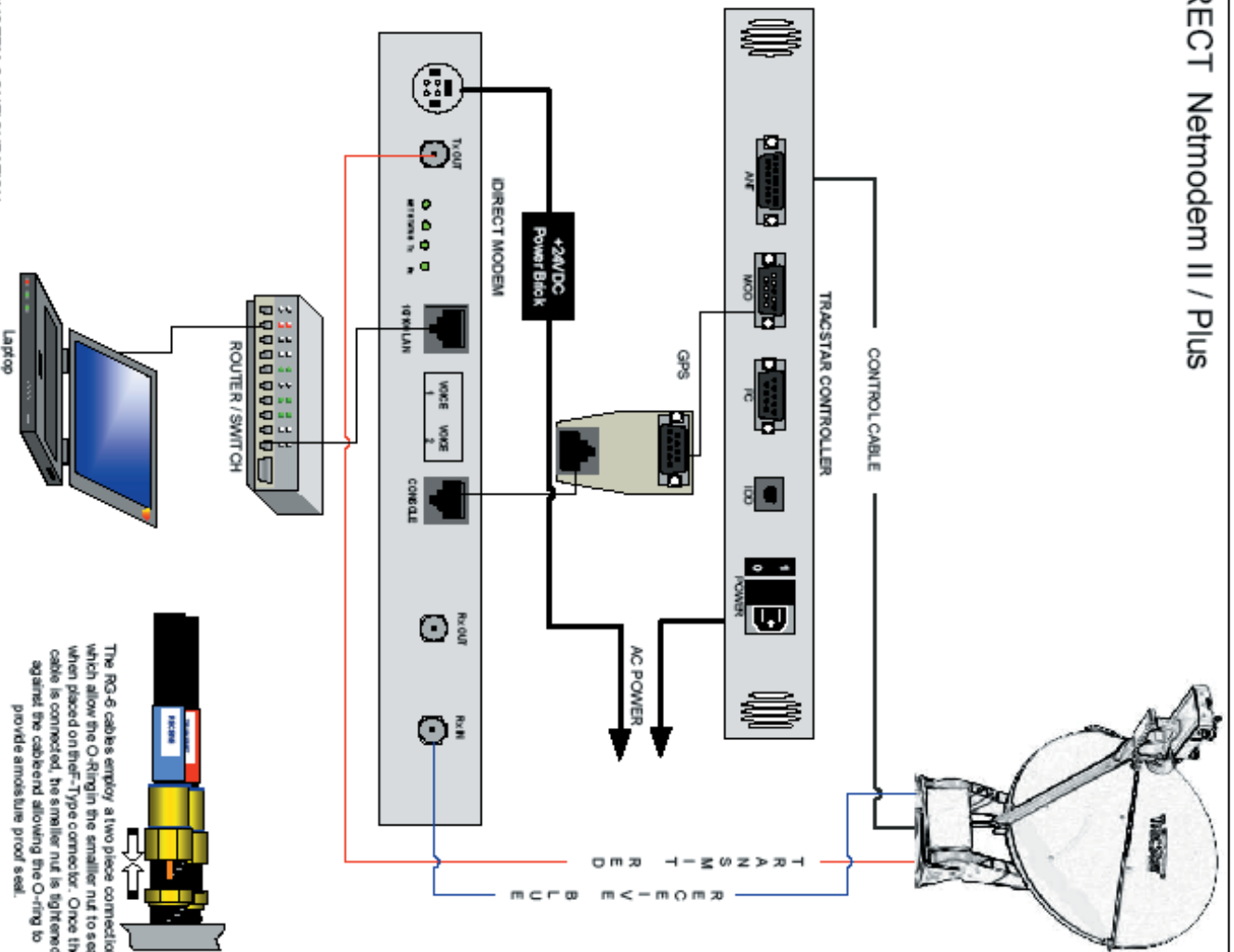

BASIC SYSTEM CONFIGURATION
VIPERSAT MODEM

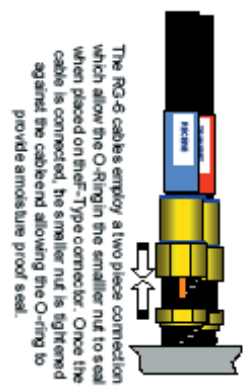

The RC-6 cables employ a two piece connection which allow the O-Ring in the smaller nut to seal when placed on their T-Type connector. Once the cable is connected, the smaller nut is tightened against the cable braid allowing the O-ring to provide atmosphere proof seal.

TracStar Systems, Inc.

Friday, March 03, 2006

iDIRECT 3000 Series Satellite Router

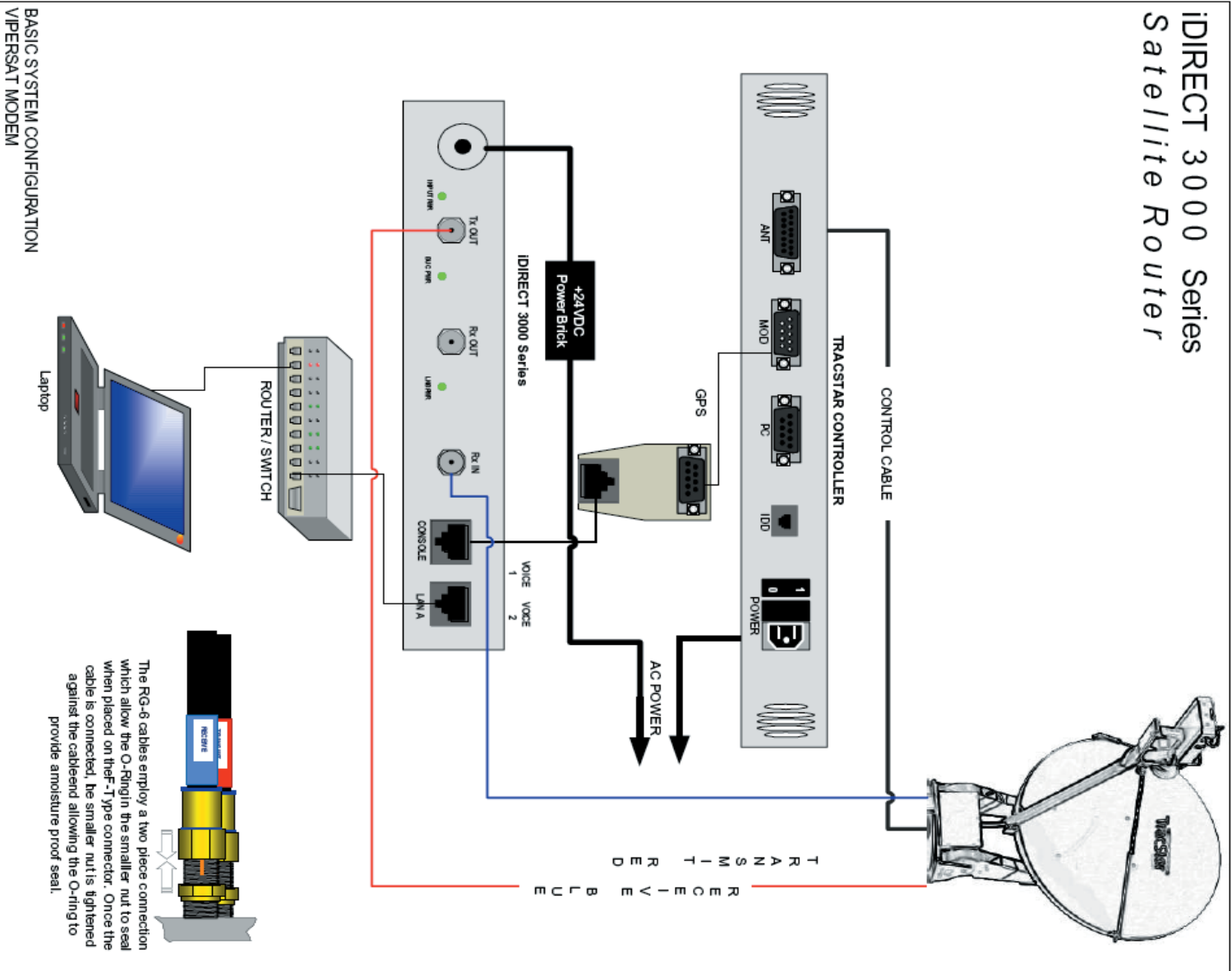

The RG-6 cables employ a two piece connection which allow the O-Ring in the smaller nut to seal when placed on the F-Type connector. Once the cable is connected, the smaller nuts tightened against the cable end allowing the O-ring to provide an moisture proof seal.

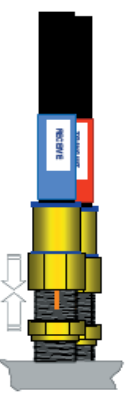

TracStar Systems, Inc.

Friday, March 03, 2006

Linkstar Connections

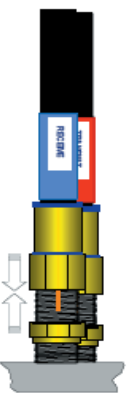
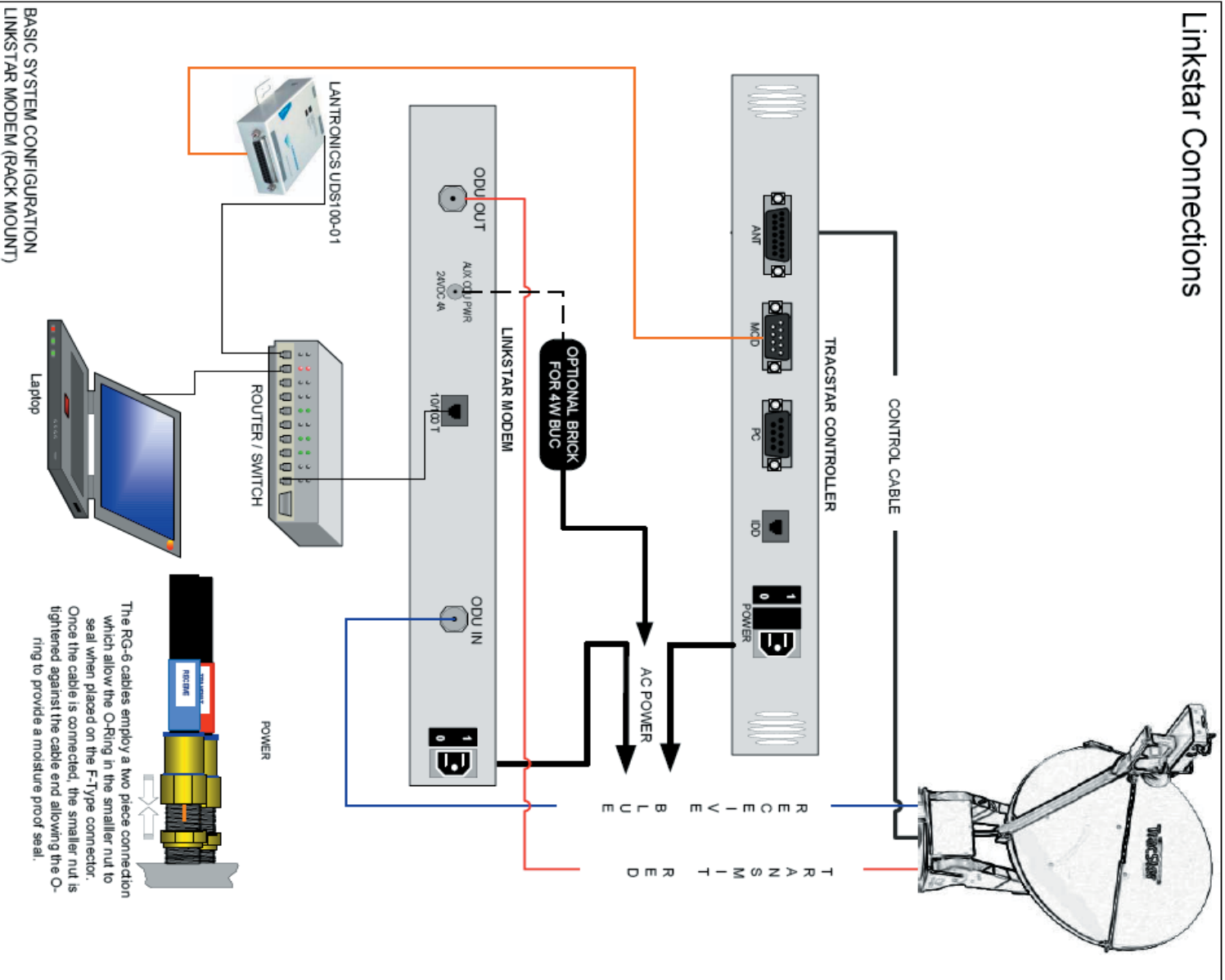

The RG-6 cables employ a two piece connection which allow the O-Ring in the smaller nut to seal when placed on the F-Type connector. Once the cable is connected, the smaller nut is tightened against the cable end allowing the O-ring to provide a moisture proof seal.

TracStar Systems, Inc.

Thursday, March 17, 2005

VIPERSAT MODEM

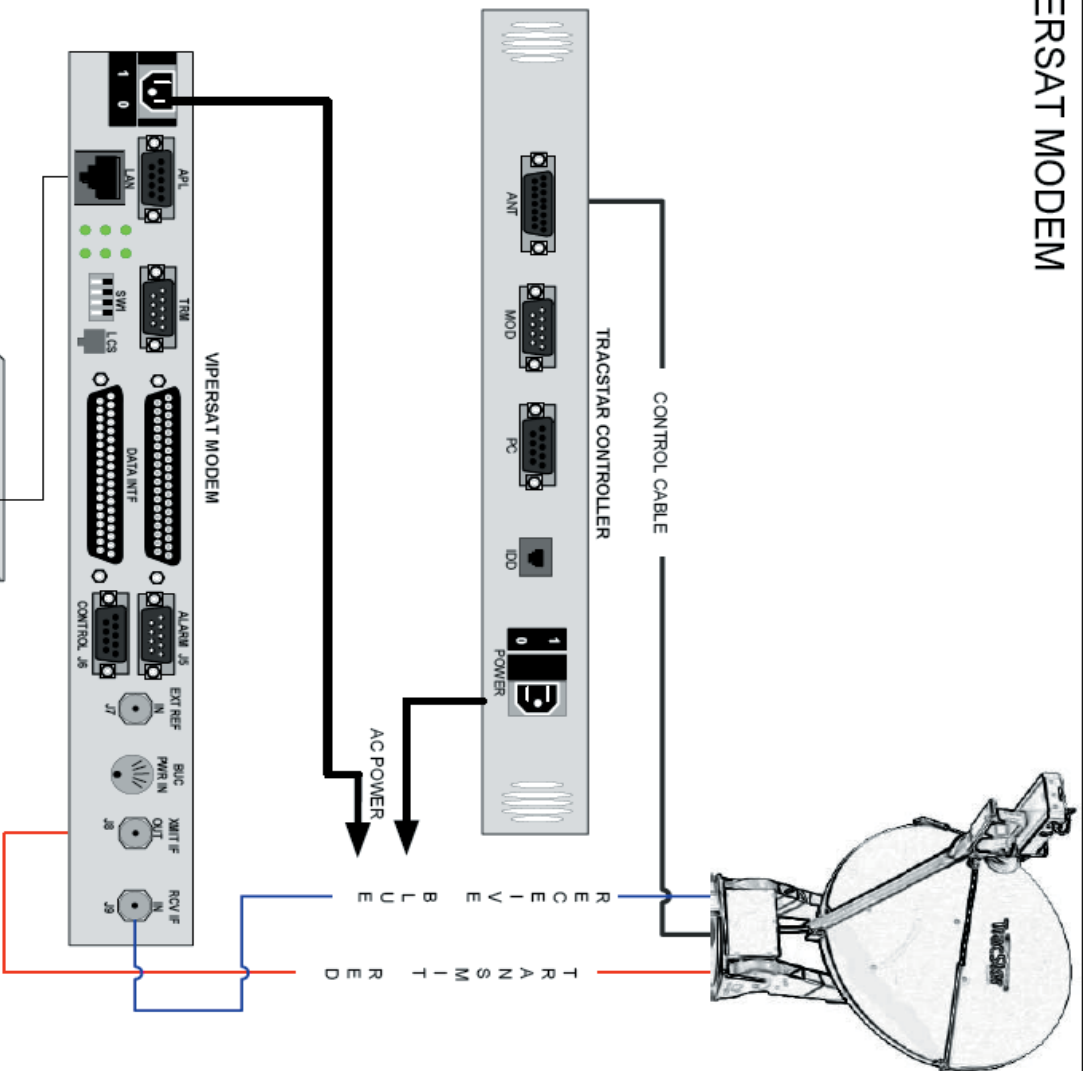

BASIC SYSTEM CONFIGURATION VIPERSAT MODEM

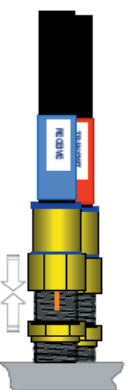
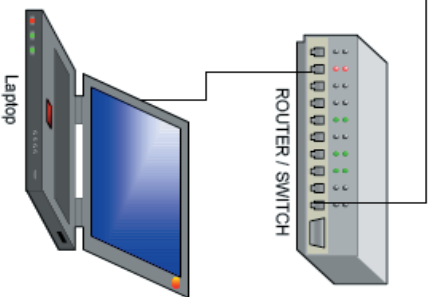

The RC-6 cables employ a two piece connection which allow the O-Ring in the smaller nut to seal when placed on the F-Type connector. Once the cable is connected, the smaller nut is tightened against the cable end allowing the O-Ring to provide a moisture proof seal.

Wednesday, March 30, 2005

TracStar Systems, Inc.

ViaSat Surf Beam Connection

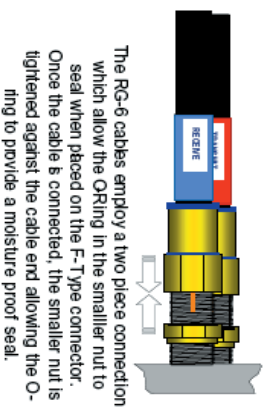
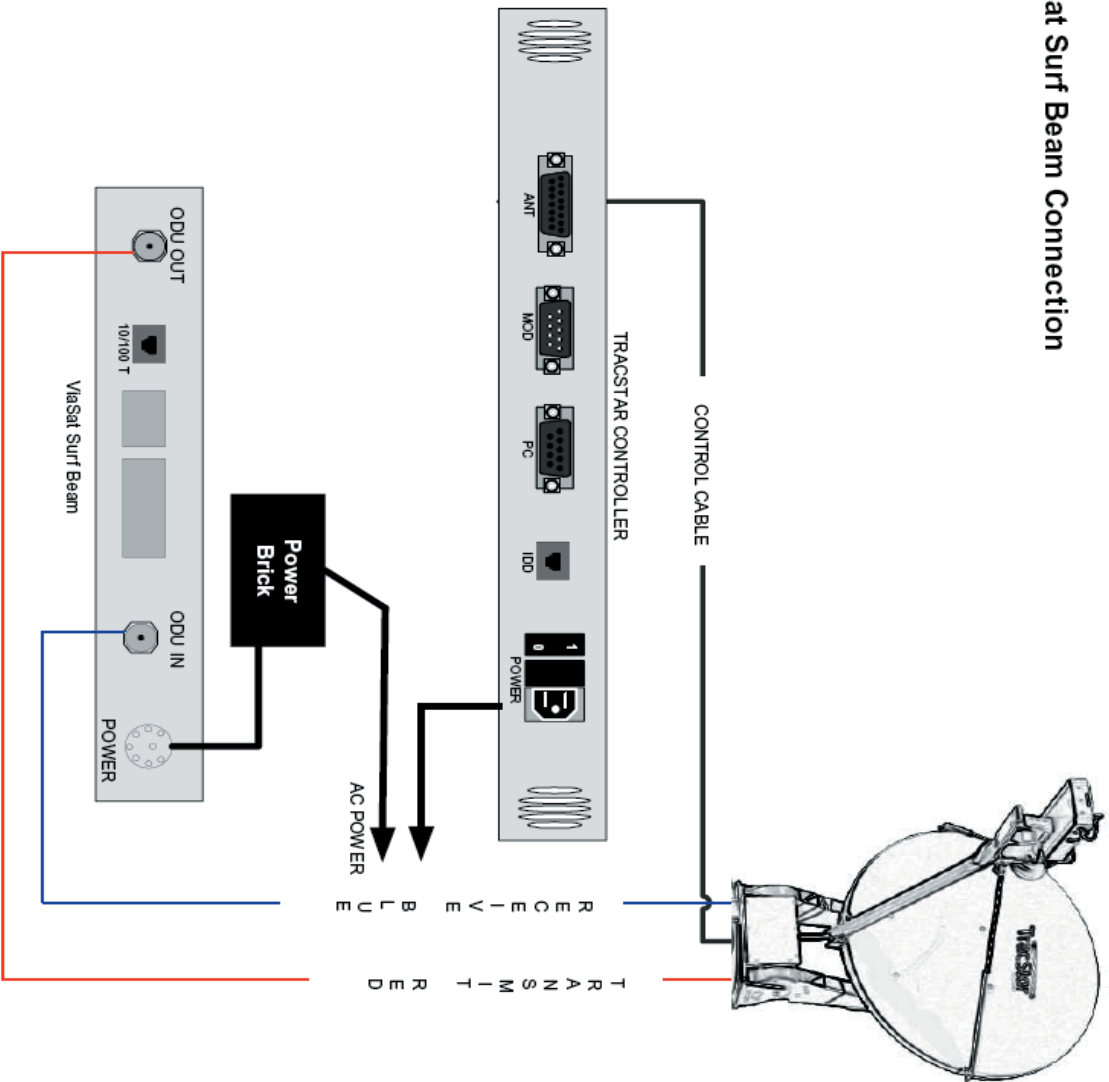

The RG-6 cables employ a two piece connection which allow the ORing in the smaller nut to seal when placed on the F-Type connector. Once the cable is connected, the smaller nut is tightened against the cable end allowing the ORing to provide a moisture proof seal.

BASIC SYSTEM CONFIGURATION
EMS TECHNOLOGIES MODEM (RACK MOUNT)

TracStar Systems, Inc.

Tuesday, March 07, 2006

System Integration Example

TYPICAL SYSTEM INTEGRATION

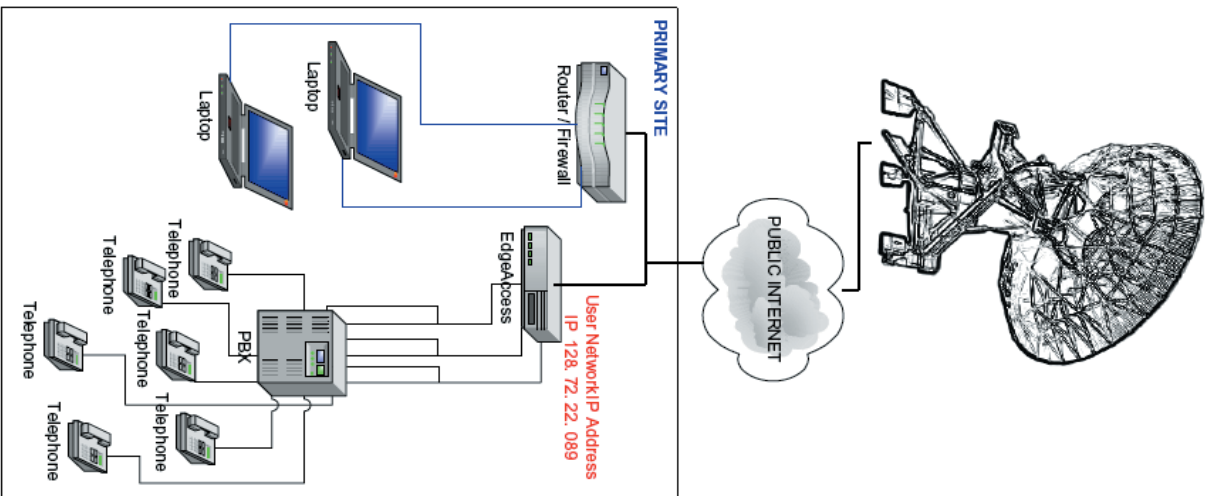

TRACSTAR SITE 950
 GATEWAY 163.78.22.84
 PUBLIC IP #1 163.78.22.85
 PUBLIC IP #2 163.78.22.86
 SUBNET MASK 255.255.255.224

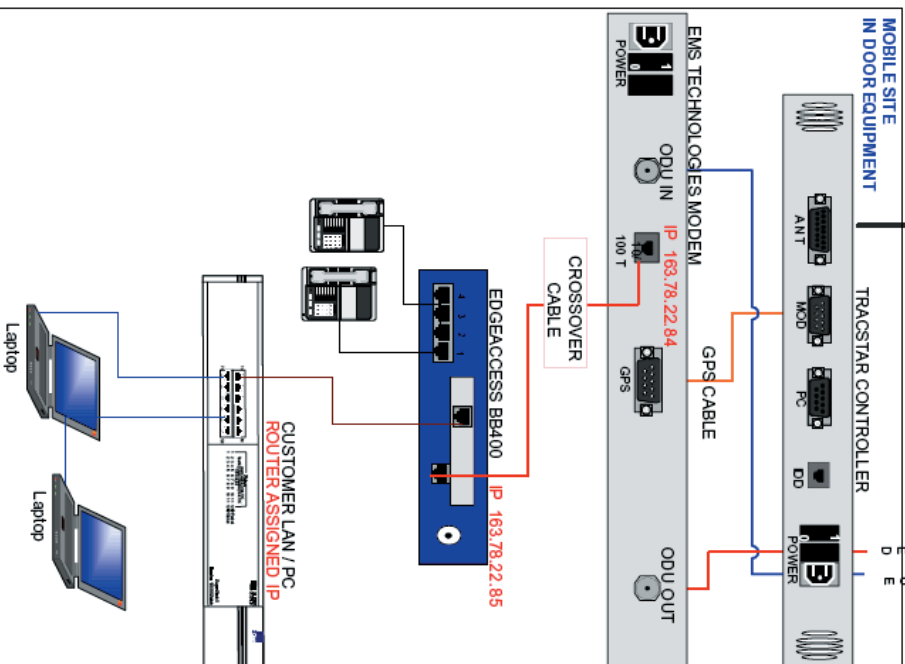
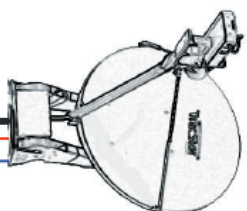

BASIC SYSTEM CONFIGURATION
 EMS TECHNOLOGIES MODEM
 EDGEACCESS VOIP EQUIPMENT

TracStar Systems, Inc.
 1984 New Hampshire Street • Orlando, FL 32804 • (407) 650-9054 • www.tracstar.net

Tuesday, February 21, 2006

TracStar Control Cable

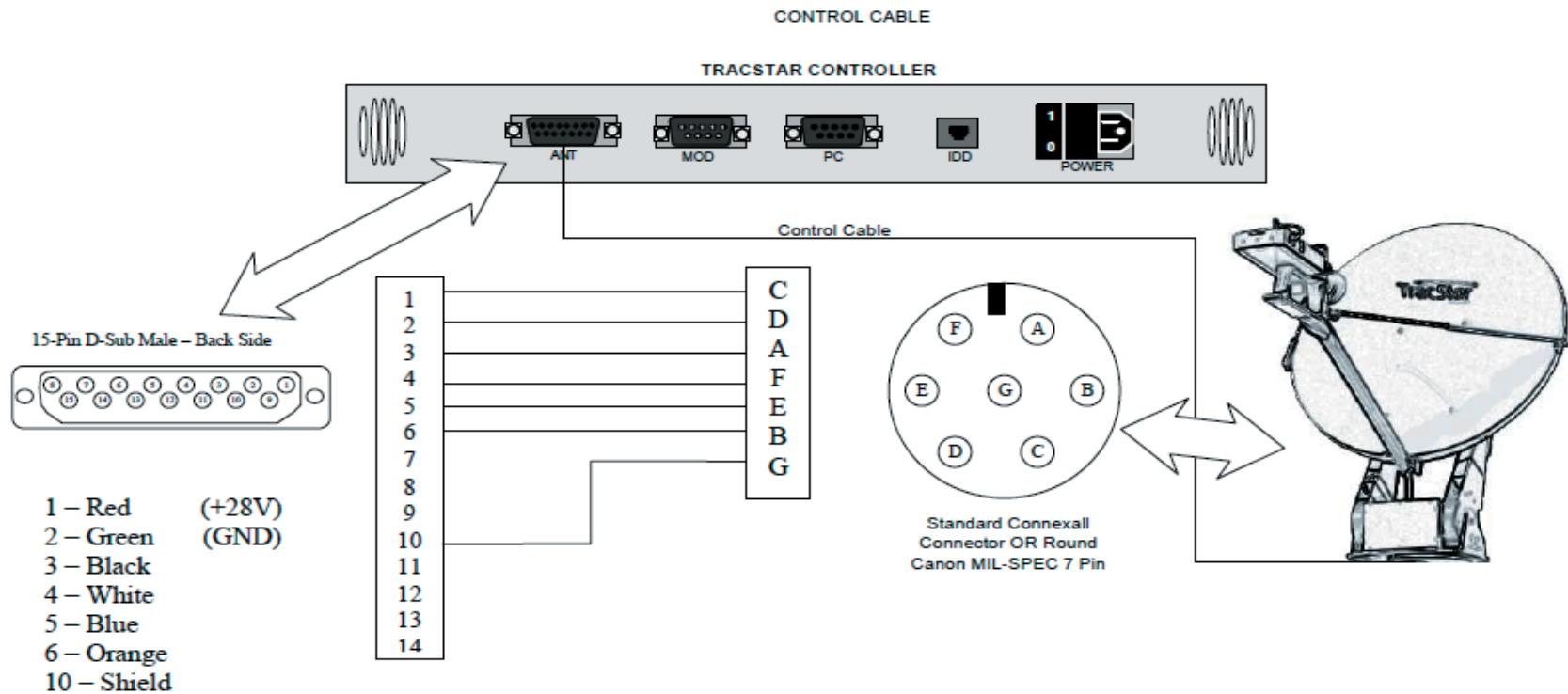

BASIC WIRING FOR MVS Series Controller Cable

Tuesday, September 16, 2008

TracStar Systems, Inc.

Console Cable Cross Over Cable

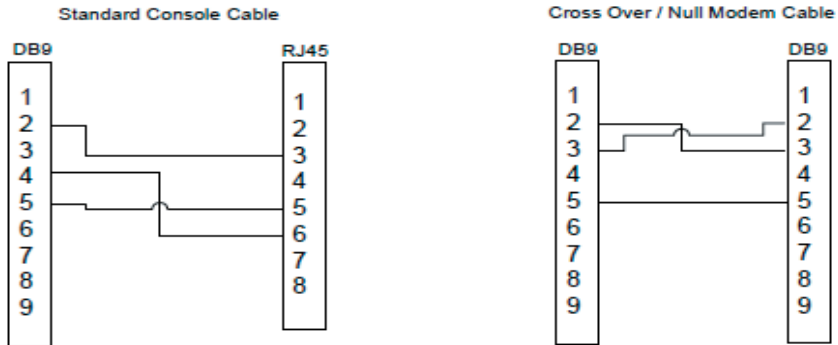

15 - Pin D Sub Male Back Side

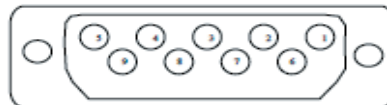

TracStar Controller Menu Grid

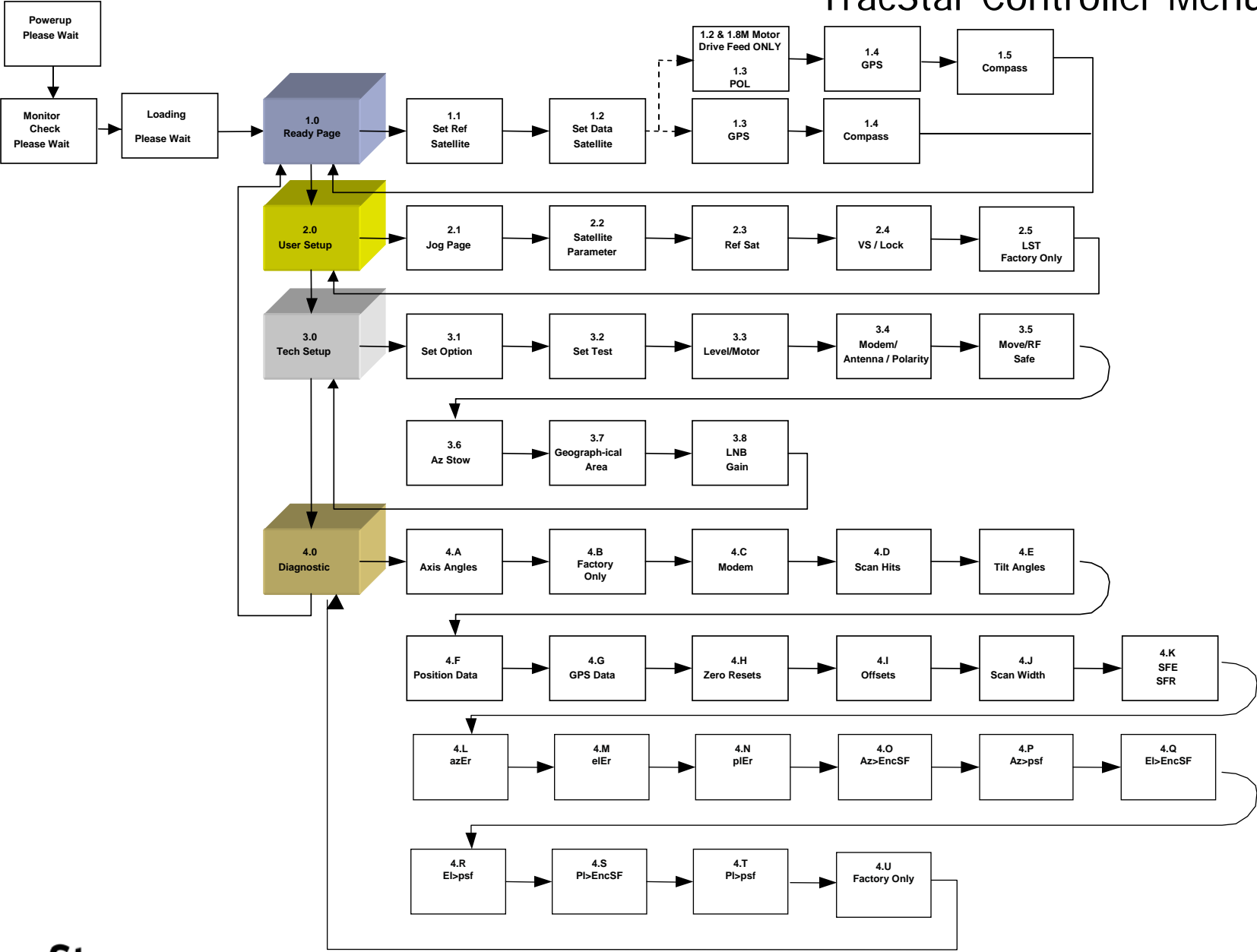

Product Certifications

- **FCC**

“This device complies with Part 15 of the FCC Rules. Operation is subject to the following two conditions: (1) this device may not cause harmful interference, and (2) this device must accept any interference received, including interference that may cause undesired operation.”

- **Industry Canada**

This Class B digital apparatus complies with Canadian ICES-003. Cet appareil numérique de la classe B est conforme à la norme NMB-003 du Canada.



- Declaration of conformity for all certifications on file. Available upon request.