

GENERAL DYNAMICS
SATCOM Technologies

4096-394

January 14, 2002

REVISION I
ASSEMBLY MANUAL

**1.8 METER
SERIES 1194 ANTENNA SYSTEM**

**GENERAL DYNAMICS
1500 Prodelin Drive
Newton NC 28658**

1.8 METER SERIES 1194 ANTENNA SYSTEM

I	Revise Cut Screws callout from 8 to 6 Pg 10	8/4/08	RAH
H	Rev HDWE 8043-032 to 8043-036	5/19/08	RAH
G	Revise Address	1/14/02	RAH
F	Revise Flat washers to 8	5/15/01	RAH
E	Revised part list on page 8	1/22/99	RAH
D	Revise Step 9 Pg. 12. $\frac{3}{4}$ " was $\frac{1}{2}$ " nut.	03/26/98	PGW
C	Revised lt. 5 – pg. 8 , was 8033-012	11/05/97	PGW
B	Updated	04/21/97	PGW
A	Revised Page #19	10/03/95	R. Frye
-	ORIGINAL RELEASE	02/02/95	R. Frye
REV.	DESCRIPTION	DATE	APPROVED

1.8M SERIES 1194 ANTENNA SYSTEM

TABLE OF CONTENTS

SECTION I	GENERAL INFORMATION	5
1.0	INTRODUCTION	5
1.1	UNPACKING AND INSPECTION.....	5
1.2	FREIGHT DAMAGE	5
1.3	MATERIAL - MISSING OR DAMAGED	5
1.4	MECHANICAL INSTALLATION TOOLS	6
1.5	FOUNDATION INTERFACE	6
1.6	SUGGESTED MAST & FOUNDATION.....	7
SECTION II	ANTENNA SYSTEM ASSEMBLY	9
2.0	ANTENNA ASSEMBLY	9
2.1	FEED SUPPORT ASSEMBLY	14
SECTION III	ANTENNA POINTING	18
3.0	ANTENNA POINTING	18
SECTION IV	MAINTENANCE	20
4.0	MAINTENANCE OVERVIEW	20
4.1	PERIODIC INSPECTION.....	20
4.2	REFLECTOR.....	20
4.3	MOUNT AND REFLECTOR SUPPORT STRUCTURE.....	21
4.4	FEED AND FEED SUPPORT.....	21

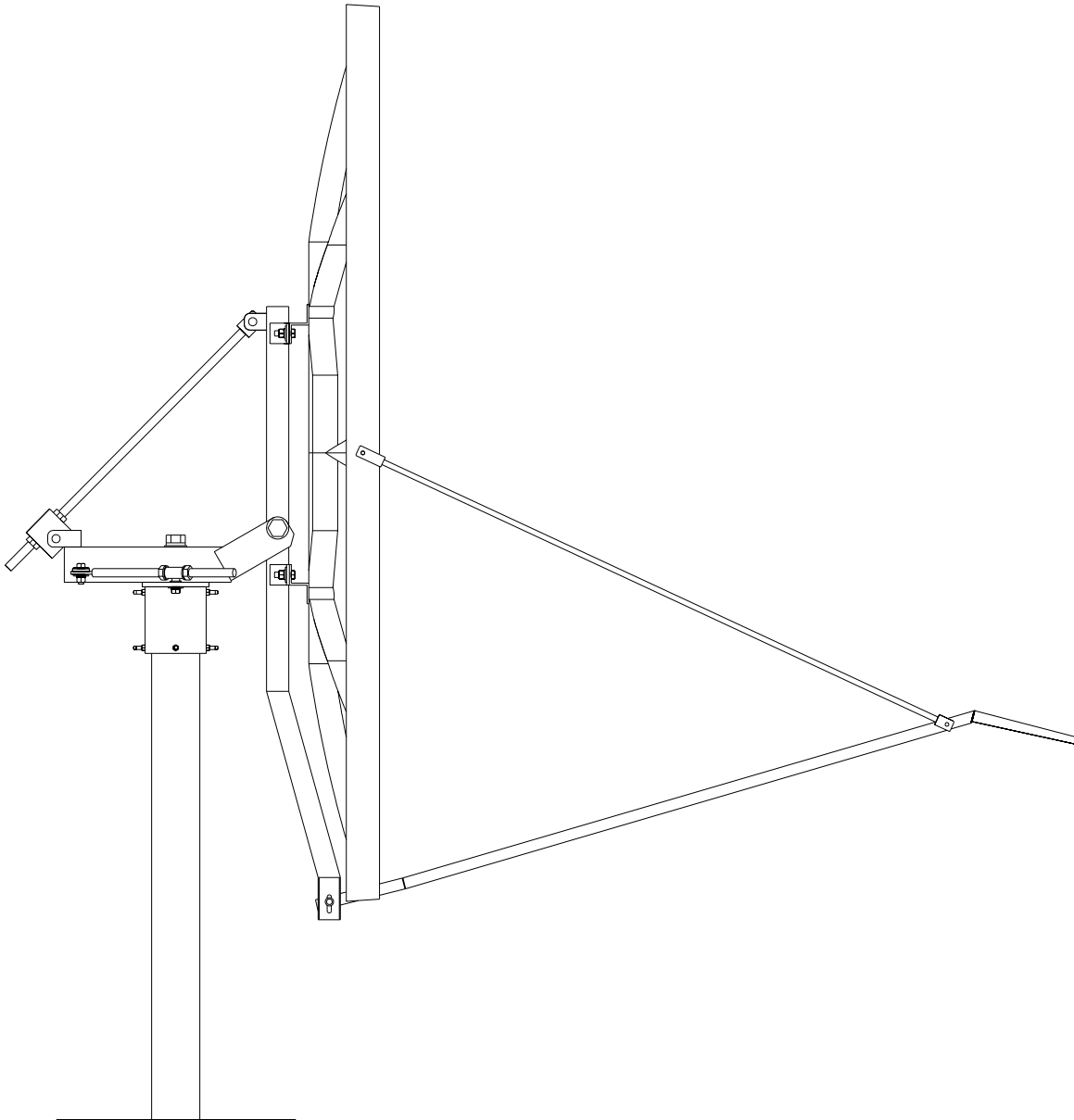

SECTION I GENERAL INFORMATION**1.0 INTRODUCTION**

This manual describes the assembly and installation of General Dynamics 1.8M Rx/Tx offset antenna system with an Az/EI mount (series number 1194). The Prodelin 1.8M is a rugged, reliable antenna system, which will operate in the 10.95 to 12.75 and 14.0 to 14.5 GHz frequency bands for Ku-Band systems with high efficiency and at the same time successfully withstand the effects of the environment.

These instructions are listed by sections that cover all areas of assembly and installation. Additional sections are included in the manual to provide information on antenna alignment to the satellite and maintenance.

1.1 UNPACKING AND INSPECTION

The antenna containers should be unpacked and inspected at the earliest date to ensure that all material has been received and is in good condition. A complete packing list for each major component is supplied.

1.2 FREIGHT DAMAGE

Any damage to materials while in transit should be immediately directed to the freight carrier. He will instruct you on matters regarding any freight damage claims.

1.3 MATERIAL - MISSING OR DAMAGED

Any questions regarding missing or damaged materials that is not due to the freight carrier should be directed to General Dynamics Customer Service Department at:

**GENERAL DYNAMICS
1500 Prodelin Drive
Newton NC 28658
USA
(828) 464-4141**

1.4 MECHANICAL INSTALLATION TOOLS

The hardware supplied with this antenna system is U.S. SAE standard size. However, the sizes have been chosen to allow use with compatibly sized metric wrenches as shown in the table below.

HARDWARE SIZE	SAE WRENCH SIZE	METRIC WRENCH SIZE	MAXIMUM REC. TORQUE
5/16" BOLT	1/2"	13 mm	12 ft-lbs (1.66 kg-m)
1/2" BOLT	3/4"	20 mm	45 ft-lbs (6.20 kg-m)
3/4" NUT	1-1/8"	28 mm	160 ft-lbs (22.07 kg-m)
1" BOLT	1-1/2"	38 mm	220 ft-lbs (30.34 kg-m)

Also recommended for installation:

Inclinometer
Compass
Adjustable Wrench

1.5 FOUNDATION INTERFACE

The required interface from the foundation to the mount is 5" schedule 40 pipe (5.56" or 14.12 cm O.D.). A suggested in-ground foundation is shown in Figure 1.

1.6 **SUGGESTED MAST & FOUNDATION**

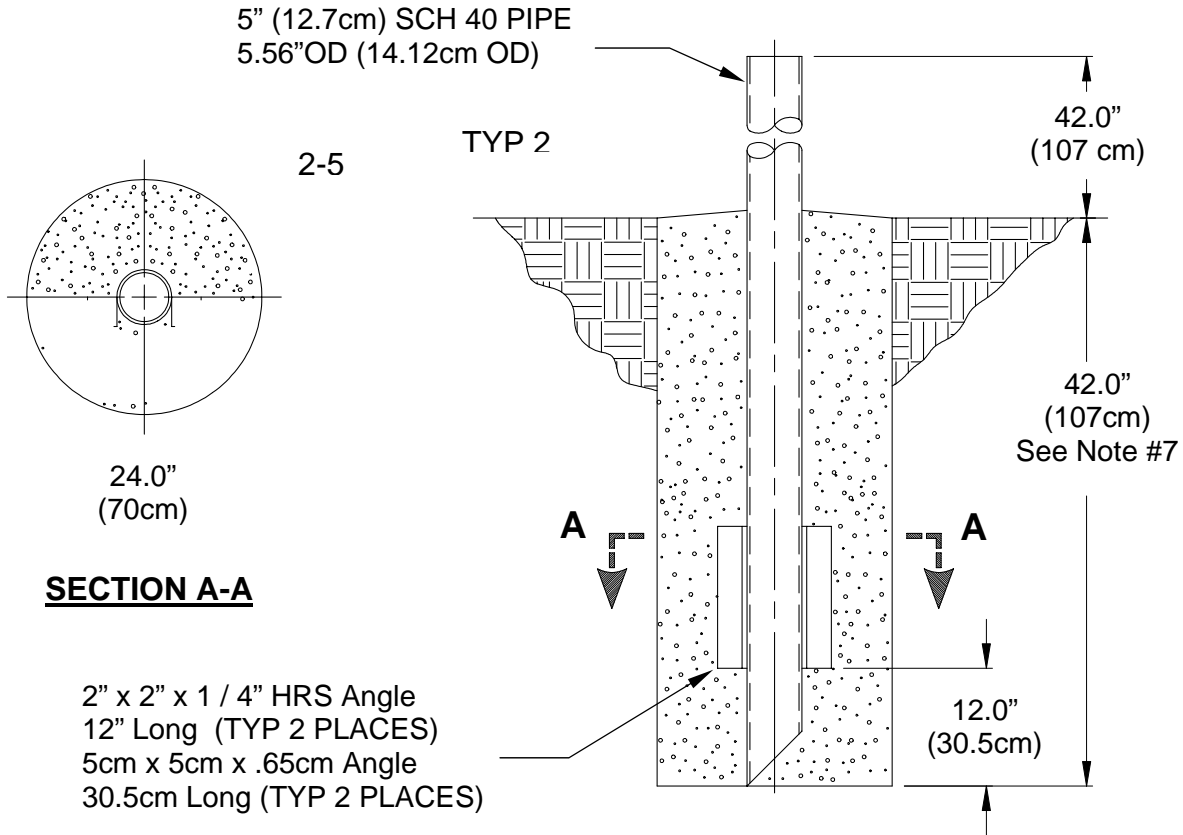
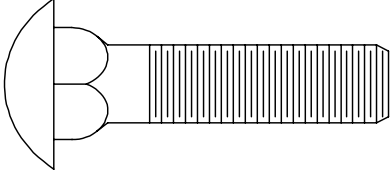
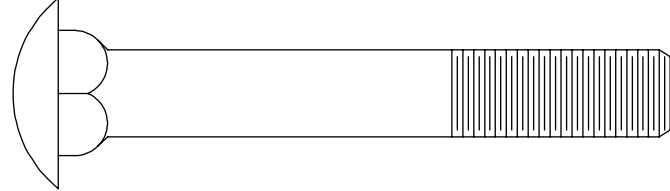
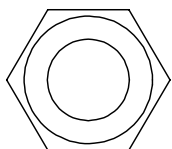
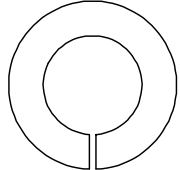
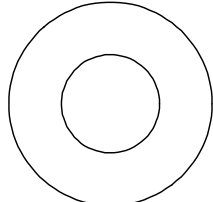

FIGURE 1.

NOTES:

1. 2 x 2 x 1/4 HRS Angle and schedule 40 pipe should conform with ASTM A36 and ASTM A53 Type E and S Grade B.
2. All concrete should conform to building code standards and have a minimum compressive strength of 3000 PSI at 28 days. (Per ACI-318-77)
3. Soil bearing capacity should be no less than 2000 PSF.
4. Concrete should be poured against undisturbed soil.
5. Allow concrete 24 hours set time before installation of antenna.
6. The antenna should be properly grounded to meet applicable local codes.
7. Minimum depth as shown or extend to local frost line.
8. Foundation meets the design requirements as set forth by the uniform building code. (1982 edition)

(PRODELIN CORPORATION DOES NOT REPRESENT OR WARRANT THAT ANY PARTICULAR DESIGN OR SIZE OF FOUNDATION IS APPROPRIATE FOR ANY LOCALITY OR EARTH STATION INSTALLATION.)

PARTS LIST - 1.8M ANTENNA ASSEMBLY			
ITEM NO.	PART NO.	DESCRIPTION	QTY
1	VARIES	1.8M Reflector	1
2	0181-648	Az/EI Positioner Assembly	1
3	0181-649	Reflector Support Tube	1
4	0247-169	Reflector Cross Arms	2
5	8043-014	1/2" x 1.75 Crg Bolt 	4
6	8043-036	1/2" x 4.50 Carriage Bolt 	4
7	8104-007	1/2" Hex Nut 	8
8	8202-043	1/2" Lockwasher 	8
9	8201-043	1/2" washer 	8

SECTION II ANTENNA SYSTEM ASSEMBLY

CAUTION: During the assembly procedure, the sequence of instructions must be followed. **Do Not Tighten Any Hardware Until Instructed.** Refer to the antenna assembly parts list and the following steps.

2.0 ANTENNA ASSEMBLY**STEP 1:**

- A). Remove azimuth rod from positioner assembly.
- B). Set azimuth rod and related hardware aside.

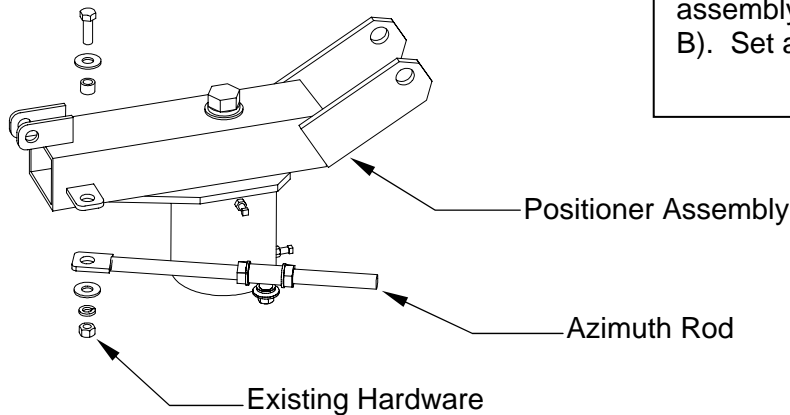
**STEP 2:**

- A). Loosen rotation bolt on top of positioner.
- B). Rotate the positioner so that the canister plate is oriented as shown.
- C). Lightly tighten rotation bolt.

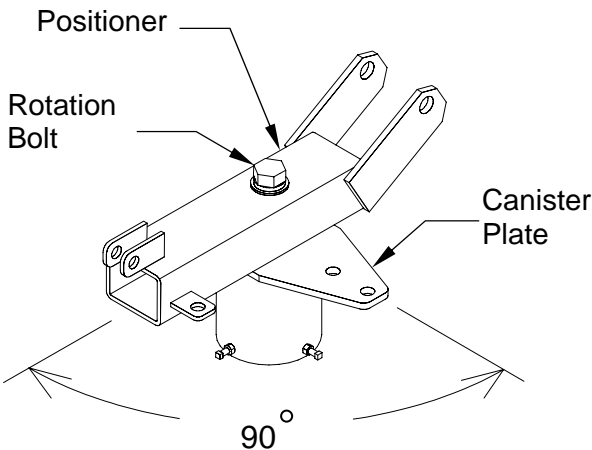

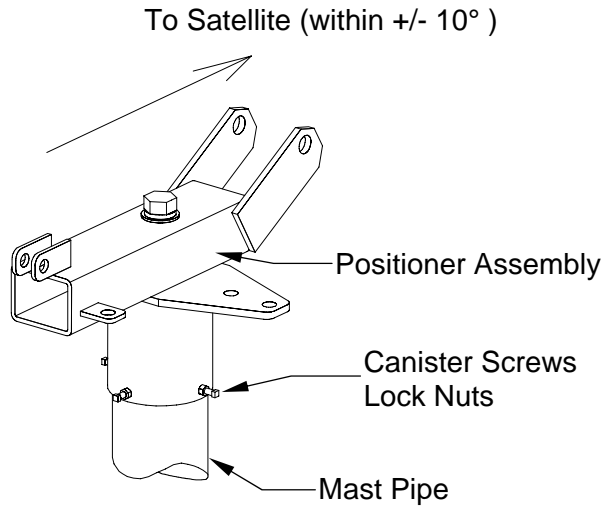

STEP 3:

- A). Place positioner assembly onto mast pipe.
- B). Orient the positioner assembly approximately towards the center of the satellite orbital arc to within +/- 10° as shown.
- C). Securely tighten [6] canister screws.
- D). Tighten [6] lock nuts against canister.

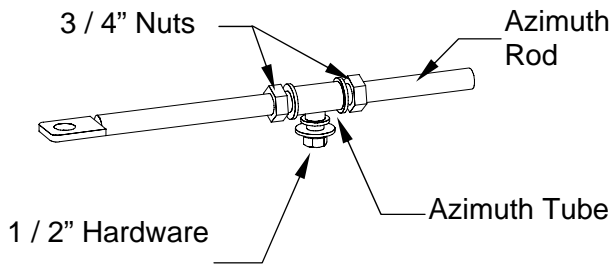

STEP 4:

- A). Locate azimuth rod (step 1.) and loosen the 3 / 4" nuts to allow movement of the azimuth tube.
- B). Remove 1 / 2" hardware from azimuth tube and set aside.

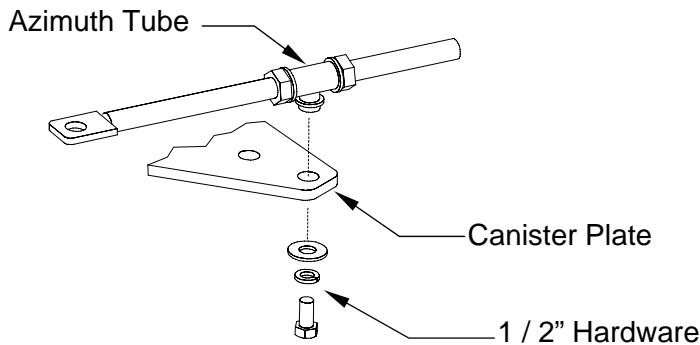

STEP 5:

- A). Locate end hole on canister plate.
- B). Position azimuth tube in hole and secure with 1 / 2" hardware from step 4.

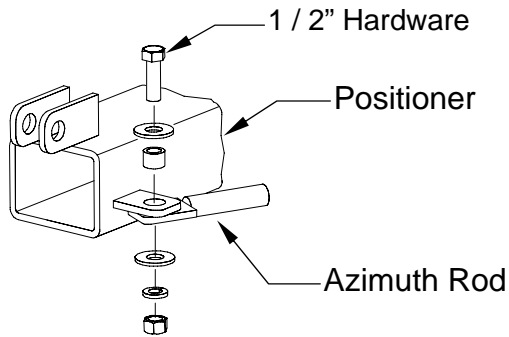

STEP 6:

- A). Rotate azimuth rod or the positioner so that the hole in the azimuth rod and the hole in the tab on the side of the positioner are lined up.
- B). Secure the azimuth rod to the positioner with the 1 / 2" hardware removed in step 1.
- C). Lightly tighten all of the azimuth adjustment hardware at this time.

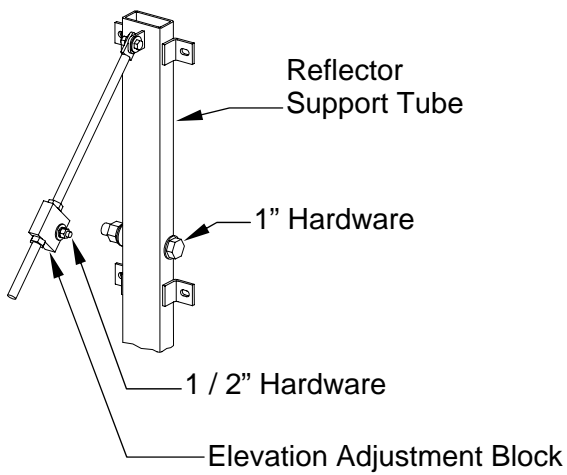

STEP 7:

- A). Remove 1" hardware from the reflector support tube.
- B). Remove 1 / 2" hardware from the elevation adjustment block and set aside.

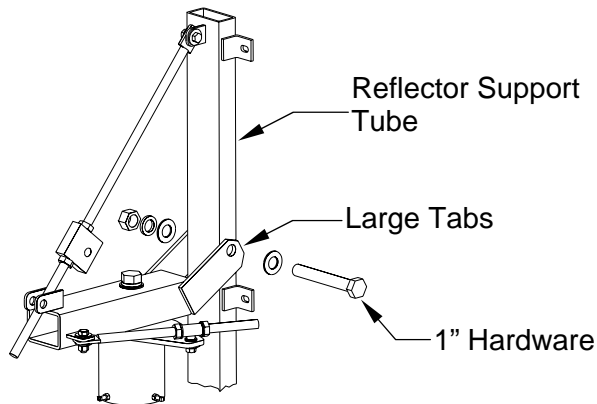

STEP 8:

- A). Place the reflector support tube in between the large tabs on the positioner as shown.
- B). Line up the holes on the tabs with the holes in the reflector support tube.
- C). Secure the support tube to the positioner with the 1" hardware.

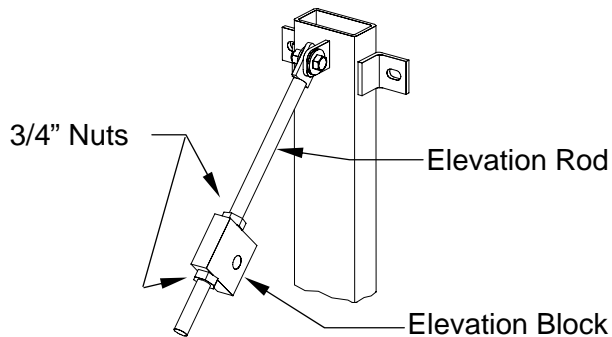

STEP 9:

- A). Loosen 3/4" nuts on elevation rod to allow movement of the elevation block.
- B). Slide elevation block down the elevation rod and position the block in between the small tabs on the positioner so that the holes in both block and tabs are aligned.

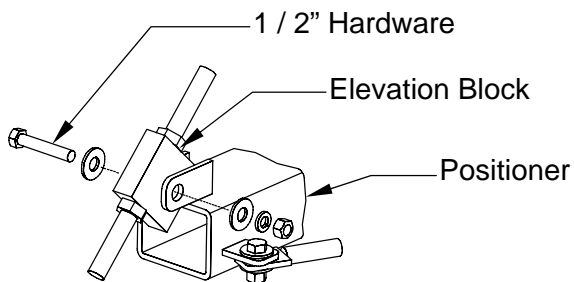

STEP 10:

- A). Secure elevation block to Positioner with 1 / 2" hardware set aside in step 7.

STEP 11:

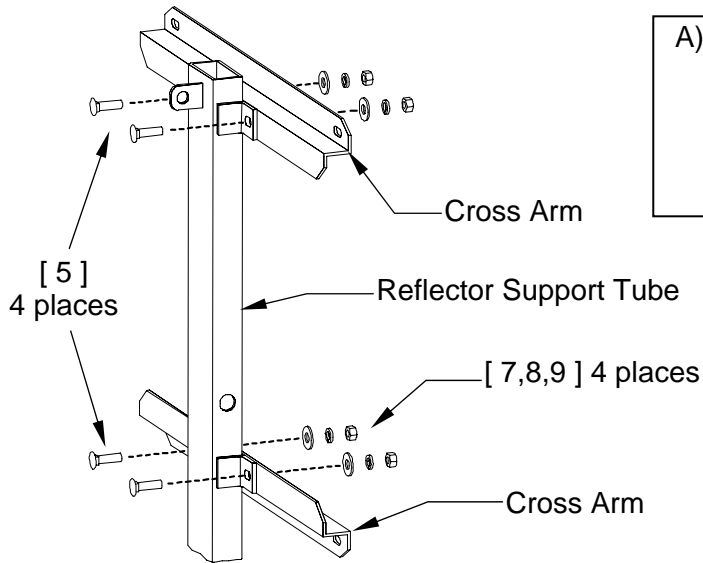

A). Attach reflector cross arms to the reflector support tube with 1 / 2" hardware (items: 5,7,8,9).

Note the orientation of cross arms.

STEP 12:

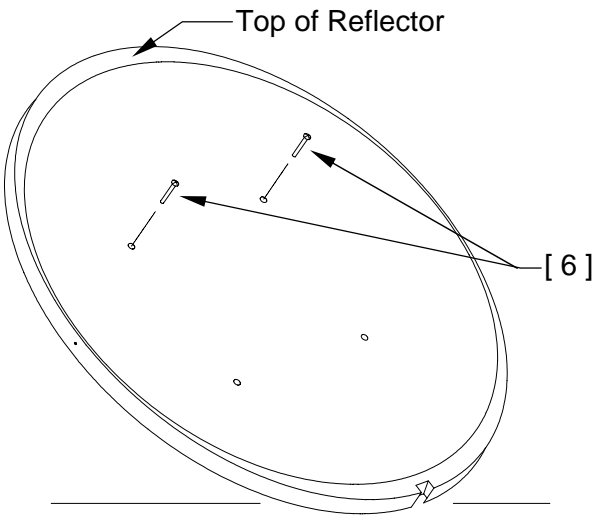

A). Locate the top of the reflector and insert 2 carriage bolts (item 6) thru top two holes on face of reflector as shown.

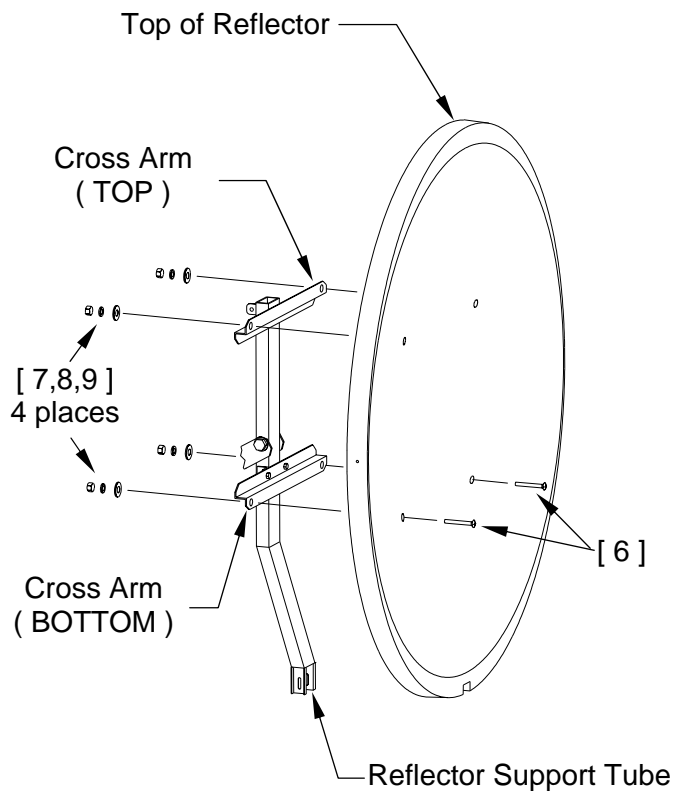

STEP 13:

- A). With a person on each side of the reflector, lift the reflector up.
- B). Position the reflector so that the 2 carriage bolts (step 12) pass thru the two holes in the top cross arm.
- C). Loosely attach 1 / 2" hardware (items,7,8,9). **Note:** the reflector is fully supported at this time.
- D). Insert the 2 remaining carriage bolts (item 6) thru the two bottom reflector mounting holes and thru holes in the bottom cross arm
- E). Secure with items: 7, 8 & 9.
- F). Tighten all reflector mounting hardware per torque specifications listed on page 6.

2.1 FEED SUPPORT ASSEMBLY

These instructions are intended as a general reference for feed support assembly. If your antenna system has specific feed support installation instructions, then refer to them at this time.

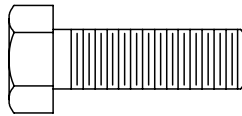
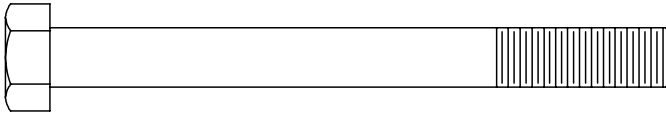
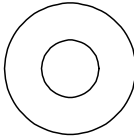
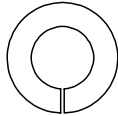
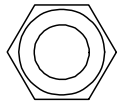
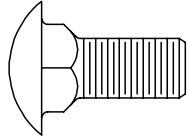
PARTS LIST - 1.8M FEED SUPPORT			
ITEM NO.	PART NO.	DESCRIPTION	QTY
1	VARIES	Feed Rod	2
2	VARIES	Feed Support Tube	1
3	8031-008	5 / 16" x 1.00" Bolt 	3
4	8031-026	5 / 16" x 3.25" Bolt 	1
5	8201-041	5 / 16" Flatwasher 	10
6	8202-041	5 / 16" Lock Washer 	6
7	8101-009	5 / 16" Hex Nut 	6
8	8038-006	5 / 16" x .75" Carriage Bolt 	2

CAUTION: During the assembly procedure, the sequence of instructions must be followed. **Do Not Tighten Any Hardware Until Instructed.** Refer to the feed support parts list and the steps shown below.

STEP 1:

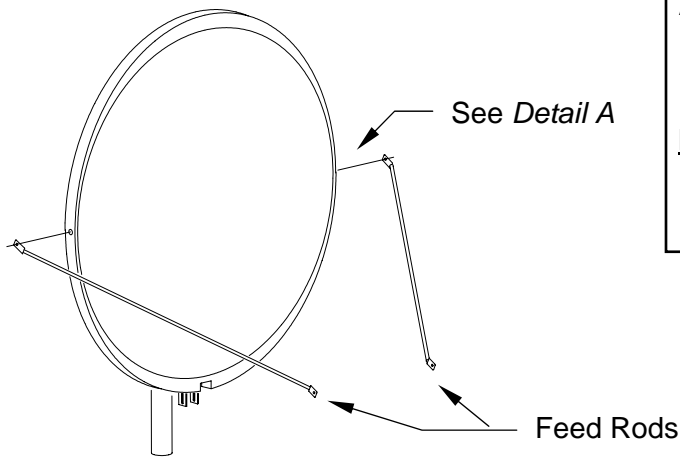

A). Attach feed rods to reflector with (items: 3, 6, 7) and with [2] of (item 5).

NOTE: The 2.00" flat end of the feed mounts to the outside rim of the reflector

STEP 2:

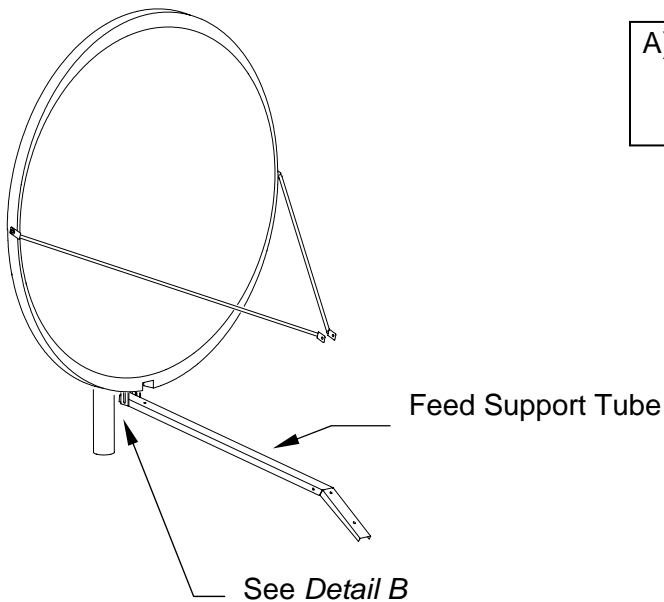

A). Mount feed support tube between the feed support brackets with [2] of (items: 8, 5, 6, 7).

STEP 3:

- A). Connect the feed rods to the feed support tube with (items: 4, 6, 7) and with [2] of (item 5).

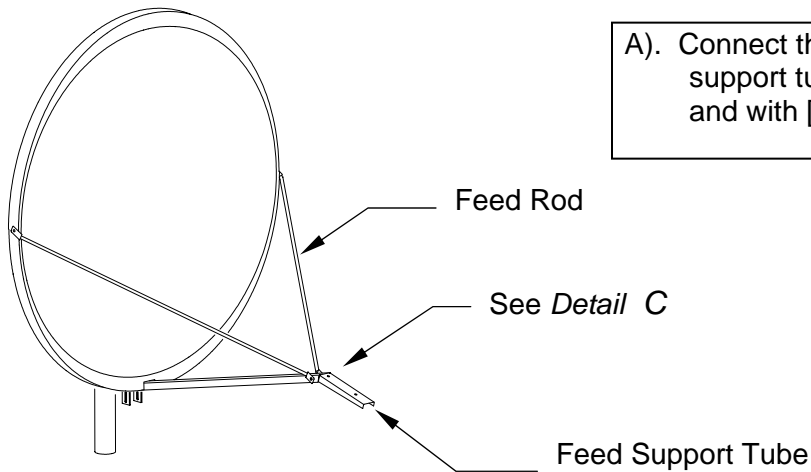

STEP 4:

- A). Attach feed support tube to the reflector with (items: 3, 6, 7) and with [2] of (item 5).
- B). Tighten the hardware at the reflector rim snugly (Detail A).
- C). Tighten the hardware connecting the feed rods to the feed support tube (Detail C).
- D). Tighten the hardware that connects the feed support tube to the feed support brackets (Detail B).
- E). Tighten the hardware connecting the feed support tube to the reflector (Detail D).
- F). Refer to separate instructions for the specific feed/ODE assembly to feed support.

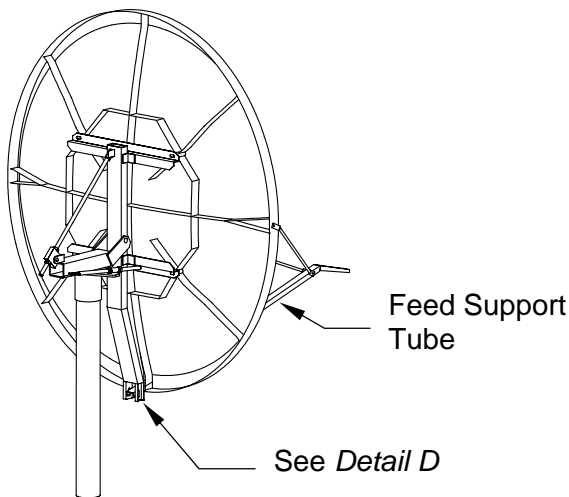

DETAIL A

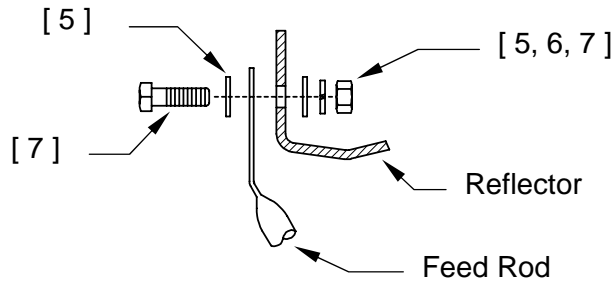

DETAIL B

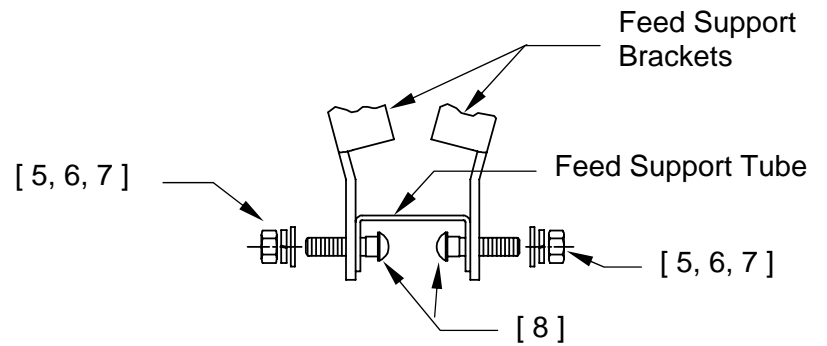

DETAIL C

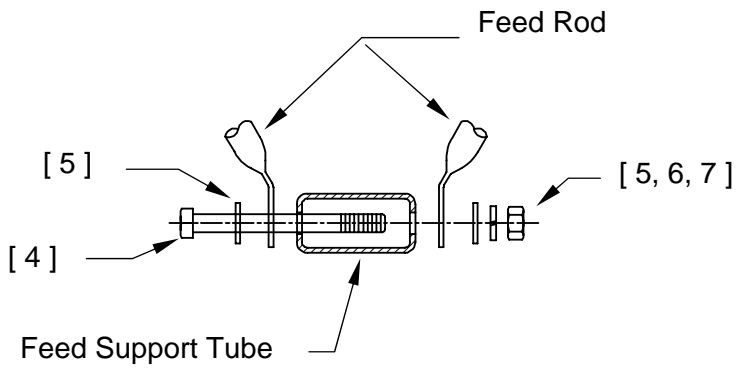

DETAIL D

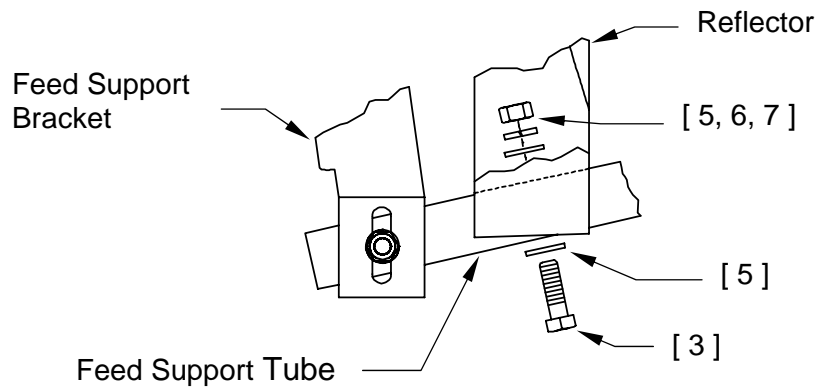

SECTION III ANTENNA POINTING**3.0 ANTENNA POINTING**

The 1.8meter reflector contains an elevation offset look angle. Therefore, when the reflector aperture is perpendicular to the ground, the antenna is actually looking 17.3° in elevation. Refer to Figure 2.

- Step 1: Place an inclinometer on the reflector support tube as shown in Figure 2. The surface allows for the offset look angle and therefore a direct reading can be taken for elevation.
- Step 2: Adjust the reflector up or down in elevation by turning the two 3/4" hex nuts at the elevation block until the desired elevation is read on the inclinometer. Snug the hardware.
- Step 3: Azimuth Adjustment: With the electronics set to acquire the satellite, rotate the antenna in azimuth until the satellite is found. Snug the azimuth adjustment hardware.
- Step 4: Peak the antenna signal by fine adjustments made in both azimuth and elevation until the optimum signal is achieved.
- Step 5: Tighten all hardware used for adjustment.

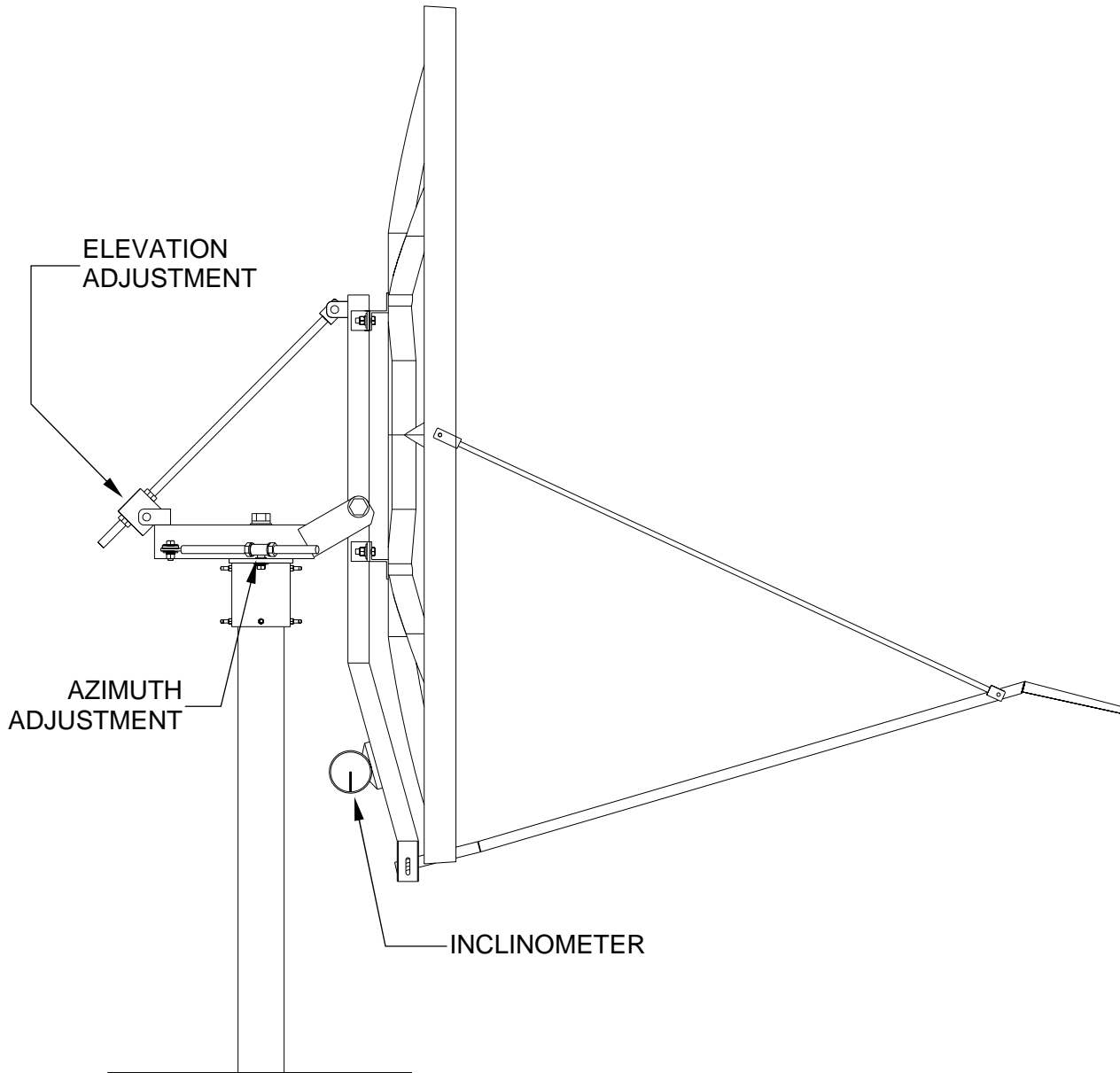

FIGURE 2.

SECTION IV MAINTENANCE

4.0 MAINTENANCE OVERVIEW

After installation, the antenna requires only periodic inspection. It is anticipated that maintenance, if required, will be minimal and easily handled by a local or in-house maintenance staff. The materials used in the construction of this Earth Station Antenna virtually eliminate any maintenance repairs.

4.1 PERIODIC INSPECTION

It is suggested that a periodic inspection be performed at least every six months.

NOTE: After any very severe weather conditions, inspection of the antenna should be performed to determine if foreign objects have caused damage or if survival specifications have been exceeded.

This inspection should include the following:

- 1) Check all bolting locations - all bolts should be tight.
- 2) Check all structural members - repair or replace if damaged.
- 3) Check the foundation anchor bolts - they must be secure and with no failure signs in foundation.
- 4) Check for corrosion - on the reflector structure and mount.

4.2 REFLECTOR

General Dynamics reflector does not require any maintenance. The composite construction of the reflector is virtually impervious to any damages that could be caused by weather or other atmospheric conditions.

It is only necessary to inspect for any physical damage done by vandalism or very severe weather conditions.

Should any damage be detected to a portion of the reflector, contact the Customer Service Department at Prodelin for recommendations involving reflector repair.

4.3 MOUNT AND REFLECTOR SUPPORT STRUCTURE

The mount and reflector support structure supplied with this antenna is of steel construction and has a hot-dipped galvanized finish.

If inspection shows any signs of structural failure, the mount members that are damaged should be repaired or replaced.

Corrosion: Any corrosion on steel members may be repaired with a cold, zinc-rich galvanizing paint.

4.4 FEED AND FEED SUPPORT

The feed support system should be inspected to insure that all hardware is secure. The feed/radio mounting bolts should be tight.

The feed horn window should be inspected to insure that it is intact so that no moisture can collect inside the feed horn. Replace if damaged.