

PRODELIN
CORPORATION

4096-236
REVISION J
January 28, 1999
ASSEMBLY MANUAL

FEED INSTALLATION INSTRUCTIONS OMT & FILTER INTERFACE

PRODELIN CORPORATION
1500 Prodelin Drive
Newton NC 28658

FEED INSTALLATION INSTRUCTIONS OMT & FILTER INTERFACE

J	Added 2.4M Section	2/4/99	
I	Removed Gilat from title	7/28/98	PGW
H	Rev for Die Cast Filter Fig 2.2-1	5/17/96	R Frye
G	Revised Figure 2.2-1	06/28/94	R Frye
F	Revised section 2.1 to show transmitter attached to thru port and Inb attached to side port per ecn #1650	04/27/94	R Frye
E	Added revision page, removed lockwashers from section 2.2	06/02/93	R. Frye
-	ORIGINAL RELEASE	01/93	R.Frye
REV.	DESCRIPTION	DATE	APPROVED

TABLE OF CONTENTS

<u>SECTION</u>	<u>TITLE</u>
I	INTRODUCTION
1.0	GENERAL INFORMATION
1.1	UNPACKING & INSPECTION
1.2	FREIGHT DAMAGE
1.3	MATERIAL MISSING OR DAMAGED
1.4	MECHANICAL INSTALLATION TOOLS
II	FEED ASSEMBLY
2.0	FEED SUPPORT ASSEMBLY
2.1	1.2M FEED SUPPORT
2.2	1.8M FEED SUPPORT
2.3	2.4M FEED SUPPORT
2.4	FEED/ODU ASSEMBLY
2.5	FEED INSTALLATION

SECTION I INTRODUCTION

1.0 GENERAL INFORMATION

This manual covers the assembly and installation of the Omt & filter interface and feed support onto the 1.2m, 1.8M, AND 2.4M Prodelin Antenna Systems.

1.1 UNPACKING AND INSPECTION

The system containers should be unpacked and inspected at the earliest date to insure that all material has been received and is in good condition. A complete packing list for each major component is supplied.

1.2 FREIGHT DAMAGE

Any damage to materials while in transit should be immediately directed to the freight carrier. He will instruct you on matters regarding any freight damage claims.

1.3 MATERIAL - MISSING OR DAMAGED

Any questions regarding missing or damaged materials that is not due to the freight carrier should be directed to Prodelin's Customer Service Department at:

**PRODELIN CORPORATION
1500 Prodelin Drive
Newton NC 28658
(828) 464-4141**

1.4 MECHANICAL INSTALLATION TOOLS

The following tools are suggested for the antenna installation.

1 ratchet

1 socket, - 7/16"

1 socket, - 1/2"

1 socket, - 9/16"

1 wrench, combination - 7/16"

1 wrench, combination - 1/2"

1 wrench, combination – 9/16"

1 wrench, adjustable - 8"

2.0 FEED SUPPORT ASSEMBLY

Refer to the section, figures and parts list for your reflector size, then follow the steps in the listed sequence. Do not tighten any hardware until instructed.

2.1 1.2M FEED SUPPORT STRUCTURE

STEP 1: Attach the [2] feed rods (item# 1) to the reflector using 11/32-14 x 7/8" hi-lo thread screws (item# 11) as shown in figure 2.0-3, detail A.
Note: If installation is a retrofit, feed rods from the existing feed may be used.

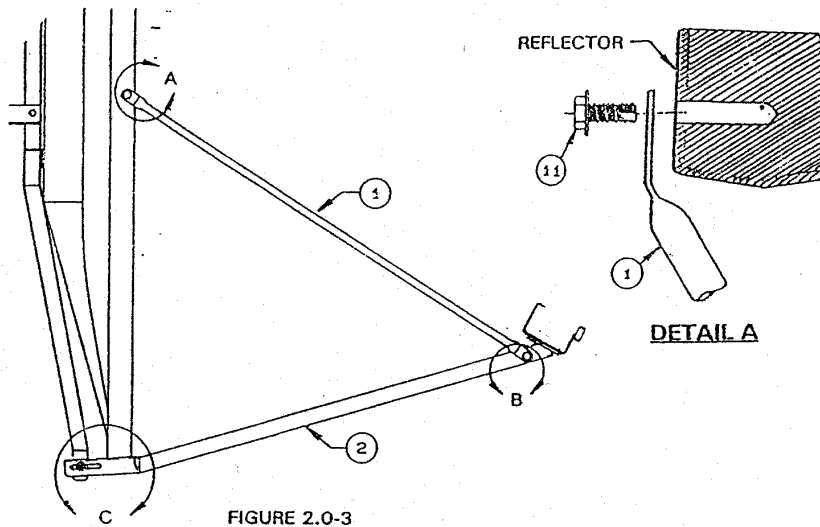

STEP 2: Connect the feed rods to the feed support tube (item# 2) with [1] 5/16-18 x 3.25" bolt, [2] flatwashers, [1] lockwasher and [1] hex nut (item# 7,8,9,10). See detail B.

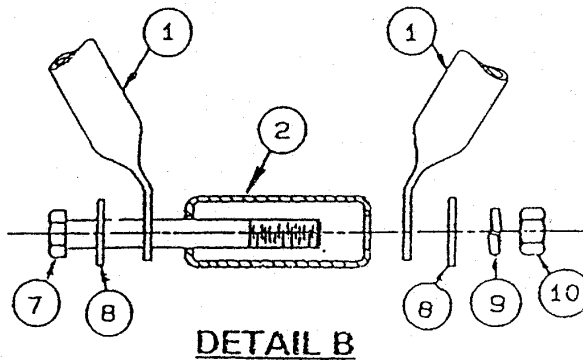

STEP 3: Mount the feed support (item# 2) between the bottom flanges of the reflector support tube with [2] 1/4-20 x 1.00" bolts, [4] flatwashers, [2] lockwashers, and [2] hex nuts (items# 3,4,5,6). See detail C.

STEP 4: Attach the feed support to the reflector with [1] 11/32-14 x 7/8" hi-lo thread screw (item# 11) as shown in detail C. Adjust the reflector laterally on the back structure as required to align the two holes.

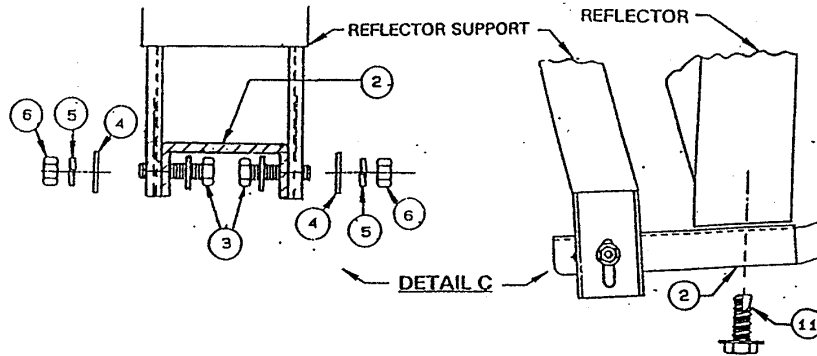

STEP 5: Tighten the [3] 11/32-14 x 7/8" screws snugly, DO NOT OVER-TIGHTEN AS THIS MAY DAMAGE THE REFLECTOR. Tighten the 5/16" hardware next, then the 1/4" hardware. Tighten the reflector mounting screws on the back structure last, BUT DO NOT OVERTIGHTEN AS THIS MAY DAMAGE REFLECTOR.

PARTS LIST			
ITEM#	PART#	DESCRIPTION	QTY
1	0176-213	FEED ROD, SIDE, 1.2M	2
2	0181-319 0490-403	FEED SUPPORT TUBE, 1.2M	1
3	8030-008	1/4-20 x 1.00" BOLT	2
4	8201-040	1/4" FLATWASHER	4
5	8202-040	1/4" LOCKWASHER	2
6	8100-007	1/4-20 HEX NUT	2
7	8031-026	5/16-18 x 3.25" BOLT	1
8	8201-041	5/16" FLATWASHER	2
9	8202-041	5/16" LOCKWASHER	1
10	8101-009	5/16-18 HEX NUT	1
11	8319-004	SCREW, 11/32-14 x 7/8" hi-lo THREAD	3

2.2 1.8M FEED SUPPORT STRUCTURE

- STEP 1:** Attach the [2] side feed rods (items# 1,2) to the reflector with a 5/16-18 x 3.75" bolt, [2] flatwashers, a lockwasher, and 5/16-18 hex nut (items# 5,6,7,8). See figure 2.0-4, detail A. Note: If installation is a retrofit, existing feed rods may be used.
- STEP 2:** Bolt these feed rods to the feed support tube (item# 3) with the 5/16-18 x 2.50" bolt, [2] flatwashers, lockwasher and 5/16-18 hex nut (items# 4,6,7,8). See detail B.
- STEP 3:** Attach the feed support tube to the reflector with another 5/16-18 x 3.75" bolt, [2] flatwashers, a lockwasher, and 5/16-18 hex nut (items# 5,6,7,8). See detail C. Tighten all hardware.

PARTS LIST			
ITEM#	PART#	DESCRIPTION	QTY
1	0176-175	FEED ROD, LEFT-HAND	1
2	0176-176	FEED ROD, RIGHT-HAND	1
3	0181-320 0181-404	FEED SUPPORT TUBE	1
4	8031-020	5/16-18 x 2.50" BOLT	1
5	8031-030	5/16-18 x 3.75" BOLT	3
6	8201-041	5/16" FLATWASHER	8
7	8202-041	5/16" LOCKWASHER	4
8	8101-009	5/16-18 HEX NUT	4

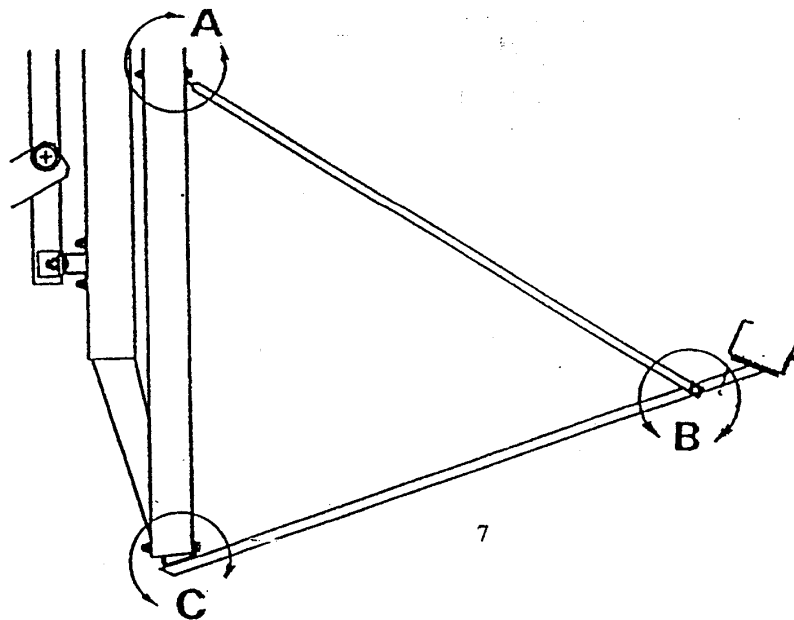
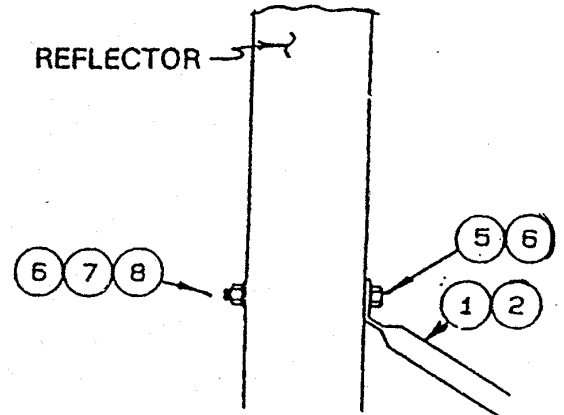
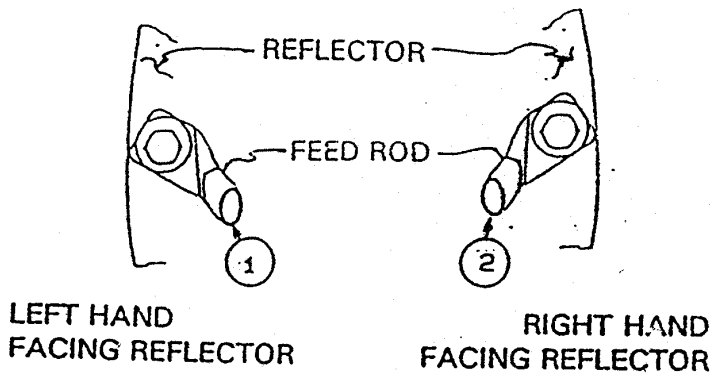
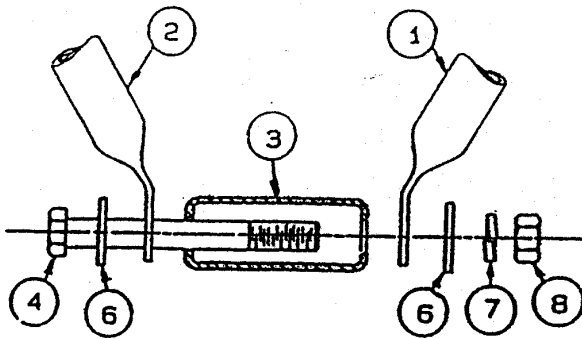

FIGURE 2.0-4



DETAIL "A"



DETAIL "B"

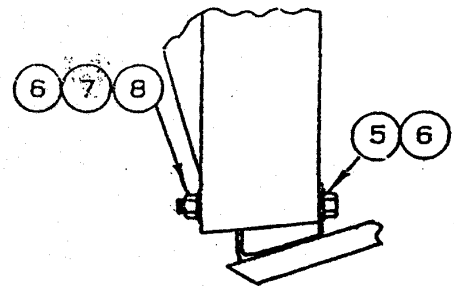

DETAIL "C"

FIGURE 2.0-4

SECTION 2.3 2.4M FEED SUPPORT ASSEMBLY

The following instructions are for installing a typical Ku-band feed support to Prodelin's 2.4 meter antenna system.

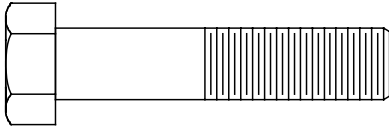
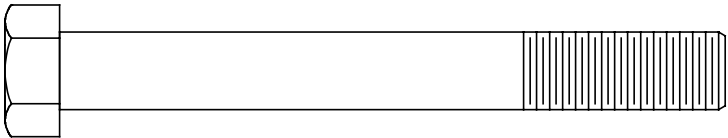
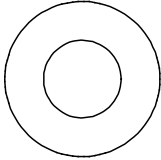
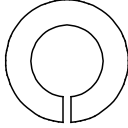
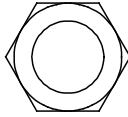
FEED SUPPORT PART LIST- TABLE 3.0			
ITEM	PART NO.	DESCRIPTION	QTY
1	VARIABLES	FEED SUPPORT	1
2	VARIABLES	FEED ROD – Ku BAND	2
3	8032-010	3/8" x 1.25 BOLT 	4
4	8032-028	3/8" x 3.50 BOLT 	1
5	8201-042	3/8" FLATWASHER 	8
6	8202-042	3/8" LOCKWASHER 	5
7	8102-007	3/8" HEX NUT 	5

2.3 Feed Support Installation

STEP 1:

Attach the feed rods loosely to the reflector with 3/8" hardware (items- 3, 5, 6 & 7). See detail A

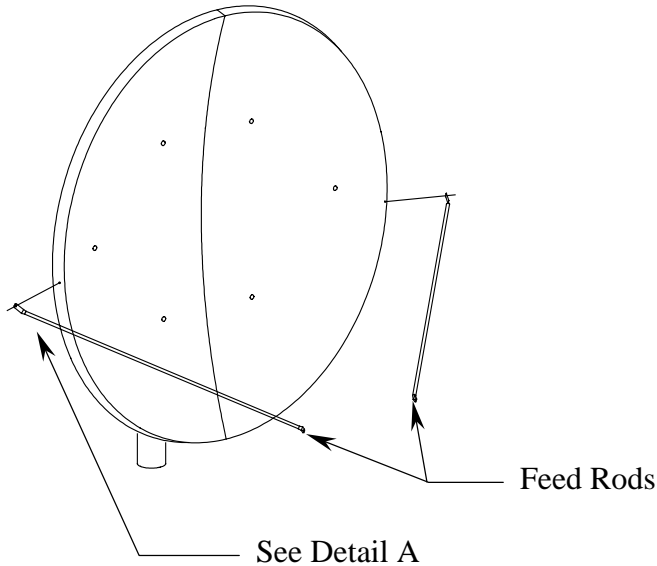

STEP 2:

Position the feed support in front of the reflector and attach to the ends of the two feed rods with 3/8" hardware (items 4, 5, 6 & 7). See Detail B. Do not tighten.

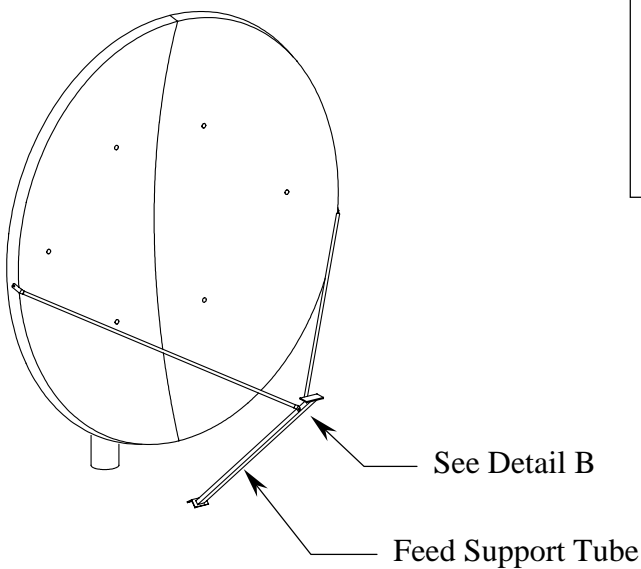

STEP 3:

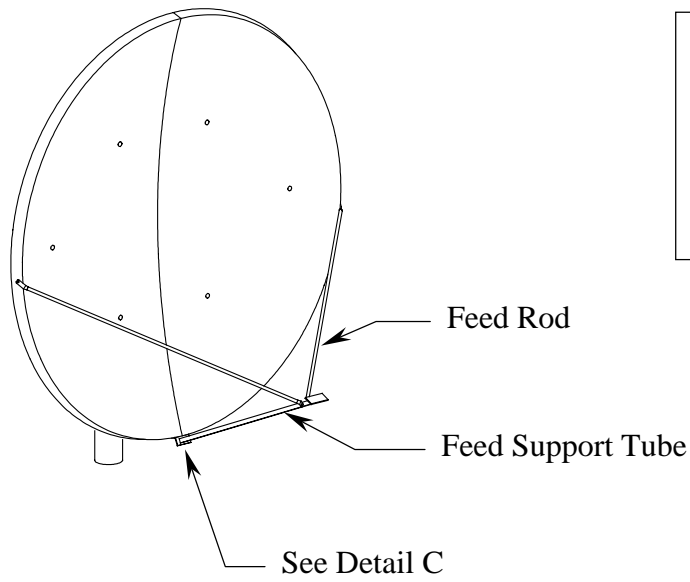

Lift the end of the feed support tube and attach to the bottom of the reflector with 3/8" hardware (items – 3, 5, 6 & 7). See Detail C. Tighten all feed support hardware at this time.

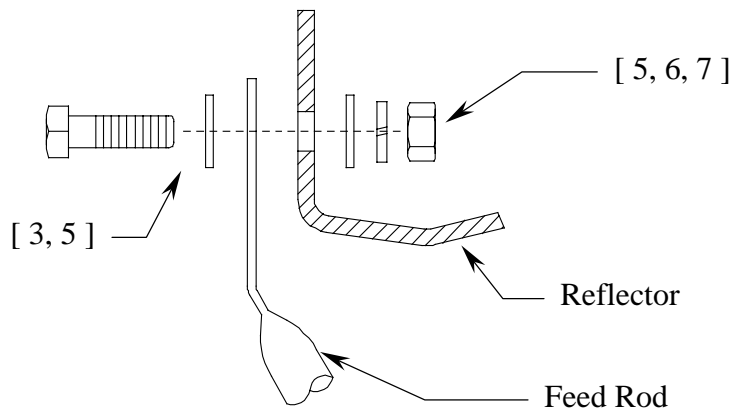

DETAIL A

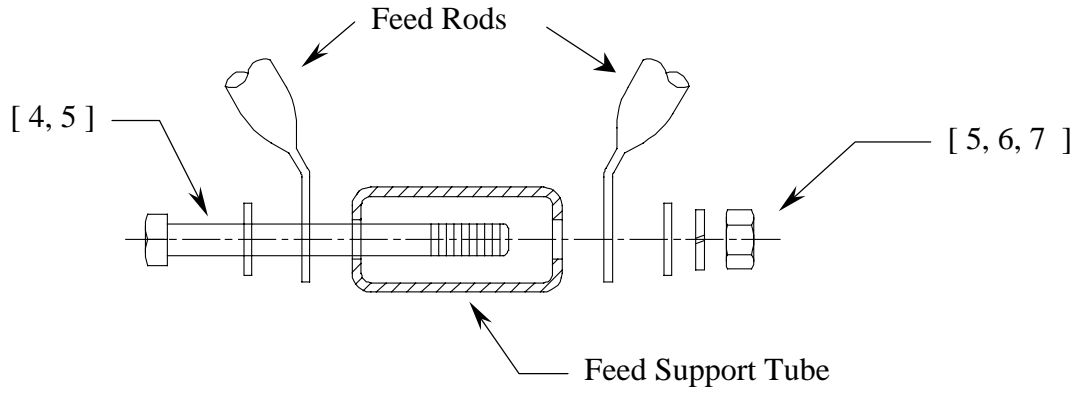

DETAIL B

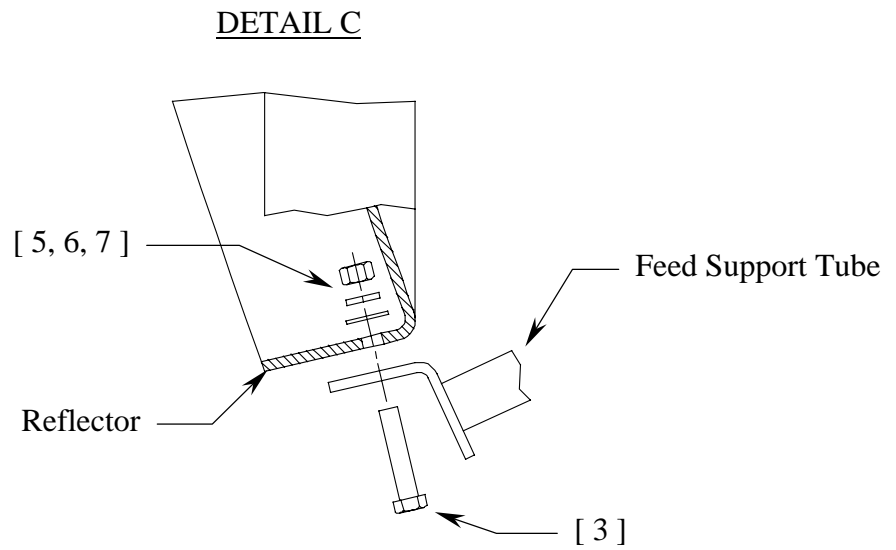

DETAIL C

2.4 FEED/ODU ASSEMBLY

STEP 1: Attach the Transmitter to the thru port of the feed assembly as shown in Figure 2.2-1. Note: remove and discard the hex nuts on the feed assembly and use the O-ring supplied with the transmitter. Tighten securely.

STEP 2: Attach the LNB to the H-Plane bend on the side port of the Feed Assembly, using o-ring and hardware supplied with the LNB. Tighten securely.

2.5 FEED INSTALLATION

- Place the feed assembly (from section 2.1 above) in the cradle of the bottom mounting bracket with the shoulder of the feed horn firmly against the face of the mounting bracket as shown in figure 2.2-1. Then attach the feed support top bracket with [2] 1/4-20 x 1.00" bolts, and [2] hex nuts. Do not tighten. Attach the radio support collar with [2] 1/4-20 x 1.00" bolts, and [2] hex nuts. The antenna system is now ready to be aligned to the satellite. After alignment and polarization adjustments are made, tighten all hardware securely.

FEED ASSEMBLY PARTS LIST			
ITEM#	PART#	DESCRIPTION	QTY
1	0188-156	COLLAR, RADIO SUPPORT	1
2	0211-400	BRKT., FEED SUPPORT, TOP	1
3	8030-008	BOLT, 1/4-20 x 1.00"	4
4	8102-007	NUT,HEX,1/4"	4
5	0183-466	FEED ASSEMBLY	1

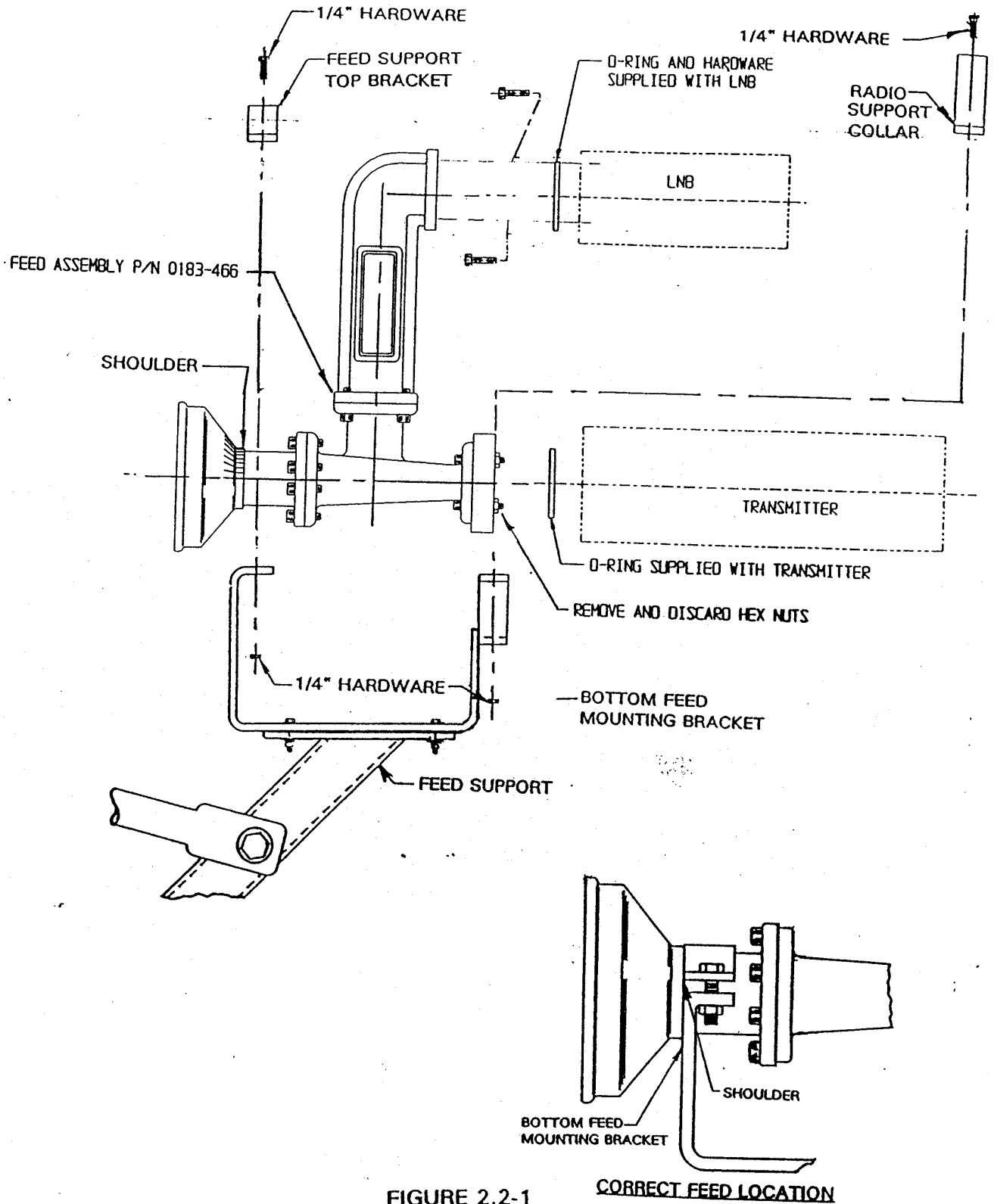

FIGURE 2.2-1